

# **Model 2900**

## **Instruction Manual**

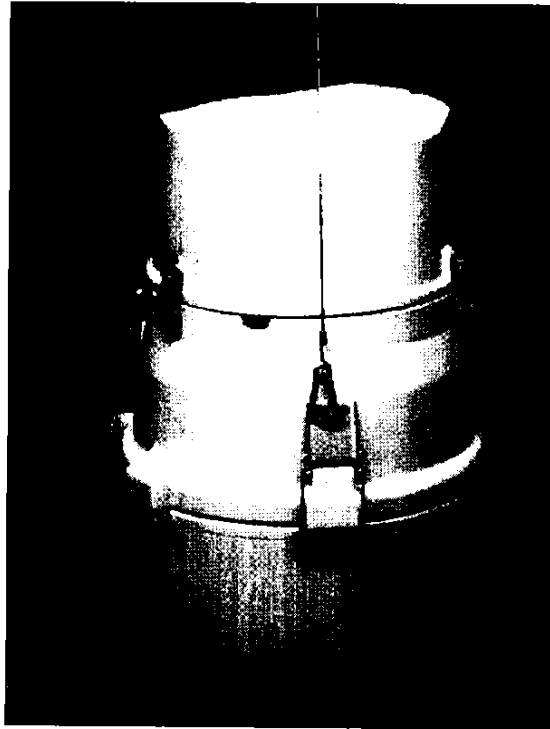

Part #60-2903-107 of Assembly #60-2904-070  
Copyright © 1991, 1996. All rights reserved, Isco, Inc.  
Revision M, September, 1996

**ISCO®**



## Foreword

This instruction manual is designed to help you gain a thorough understanding of the operation of the equipment. Isco recommends that you read this manual completely before placing the equipment in service.

Although Isco designs reliability into all equipment, there is always the possibility of a malfunction. This manual may help in diagnosing and repairing the malfunction.

If the problem persists, call or email the Isco Customer Service Department for assistance. Contact information is provided below. Simple difficulties can often be diagnosed over the phone. If it is necessary to return the equipment to the factory for service, please follow the shipping instructions provided by the Customer Service Department, including the use of the **Return Authorization Number** specified. **Be sure to include a note describing the malfunction.** This will aid in the prompt repair and return of the equipment.

Isco welcomes suggestions that would improve the information presented in this manual or enhance the operation of the equipment itself.

### Contact Information

Phone:	(800) 228-4373	(USA, Canada, Mexico)
	(402) 464-0231	(Outside North America)
Repair Service:	(800) 775-2965	(Analytical and Process Monitoring Instruments)
	(800) 228-4373	(Samplers and Flow Meters)
Fax:	(402) 465-3022	
Email address:	info@isco.com	
Website:	www.isco.com	
Return equipment to:	4700 Superior Street, Lincoln, NE 68504-1398	
Other correspondence:	P.O. Box 82531, Lincoln, NE 68501-2531	



# Model 2900 Sampler

## TABLE OF CONTENTS

Section No.	Title	Page No.
	CHAPTER 1	
1.0	INTRODUCTION.....	1-1
1.1	Manual Organization.....	1-1
1.2	Description of the Model 2900 Sampler.....	1-1
1.3	Controls, Indicators, and Connectors.....	1-3
1.4	Technical Specifications .....	1-3
	CHAPTER 2	
2.0	OPERATING PROCEDURES .....	2-1
2.1	Preparation for Use.....	2-1
2.1.1	Assembly and Disassembly of the Case.....	2-1
2.1.2	Preparation of the 24-Bottle Tub .....	2-1
2.1.3	Preparation of the 12 Bottle Tub .....	2-2
2.1.4	Cooling the Samples .....	2-4
2.1.5	Attaching the Suction Line .....	2-4
2.1.5.1	1/4 Inch ID Vinyl Suction Line .....	2-4
2.1.5.2	3/8 Inch ID Vinyl Suction Line .....	2-5
2.1.5.3	3/8 Inch ID Teflon Suction Line .....	2-5
2.1.6	Placement of the Suction Line and Intake.....	2-5
2.1.6.1	Replacing the Suction Line on the Strainer .....	2-8
2.1.7	Placement of the Sampler .....	2-9
2.1.7.1	Safety Procedures .....	2-9
2.1.7.1.1	General Safety Procedures .....	2-9
2.1.7.1.2	Lethal Atmospheres in Sewers.....	2-14
2.1.7.2	General Installation Procedures.....	2-15
2.1.8	Connection to Power Source .....	2-15
2.1.9	Connection to a Flow Meter.....	2-16
2.1.9.1	Isco Flow Meters and Flow Loggers .....	2-16
2.1.9.2	Non-Isco Flow Meters.....	2-16
2.2	Setting Up a Sampling Program .....	2-17
2.2.1	Types of Samples.....	2-18
2.2.2	Programming Overview.....	2-19
2.2.3	Description of Controls and Indicators.....	2-19
2.2.3.1	Keypad.....	2-19
2.2.3.1.1	CONTROL KEYS .....	2-21
2.2.3.1.2	NUMBER KEYS.....	2-21
2.2.3.1.3	PROGRAM KEYS .....	2-21
2.2.3.2	Display .....	2-23
2.2.3.3	Humidity Indicator.....	2-34
2.2.4	General Programming Considerations.....	2-34
2.2.5	Standard Programming .....	2-37
2.2.5.1	Sequential Time.....	2-37
2.2.5.2	Sequential Flow.....	2-42
2.2.5.3	Composite Time.....	2-45
2.2.5.4	Composite Flow.....	2-48
2.2.6	Advanced Programming .....	2-53
2.2.6.1	Calibrate Sample Volume.....	2-53
2.2.6.2	Liquid Level Sampler Actuator Modes.....	2-56
2.2.6.3	Program Halt/Resume.....	2-57
2.2.6.3.1	Selecting Units of Measure .....	2-58
2.2.6.4	Program Lock.....	2-60
2.3	Placing the Sampler into Operation .....	2-61
2.4	Sample Recovery .....	2-62

## Model 2900 Sampler

Section No.	Title	Page No.
<b>CHAPTER 3</b>		
3.0	ROUTINE MAINTENANCE .....	3-1
3.1	Cleaning the Sampler.....	3-1
3.1.1	Case .....	3-1
3.1.2	Tubing .....	3-1
3.1.3	Sample Bottles .....	3-1
3.1.4	Cleaning Protocols for Priority Pollutants .....	3-1
3.2	Replacement of Pump Tubing .....	3-2
3.3	Replacement of Suction Tubing .....	3-6
3.3.1	1/4 Inch ID Vinyl Suction Line .....	3-6
3.3.2	3/8 Inch ID Vinyl Suction Line .....	3-6
3.3.3	3/8 Inch ID Teflon Suction Lines .....	3-7
3.3.4	Conversion for Composite Sampling .....	3-7
3.4	Changing the Internal Desiccant .....	3-9
 <b>CHAPTER 4</b>		
4.0	OPTIONS .....	4-1
4.1	Sampler Locking.....	4-1
 <b>CHAPTER 5</b>		
5.0	CONSTRUCTION OF THE MODEL 2900 SAMPLER .....	5-1
5.1	Description of Mechanical Construction .....	5-1
5.1.1	Weather and Corrosion Resistance .....	5-1
5.1.2	Pump and Pump Drive System.....	5-1
5.1.3	Liquid Distribution System.....	5-2
5.2	Electronic Circuitry .....	5-3
 <b>CHAPTER 6</b>		
6.0	SERVICING AND TROUBLESHOOTING .....	6-1
6.1	Replacement of the Fuse.....	6-1
6.2	Removal of the Control Box .....	6-1
6.3	Hints on Troubleshooting and Repair of CMOS Circuitry.....	6-3
6.4	Access to Electronic and Other Internal Components .....	6-3
6.5	Self-Diagnostics.....	6-6
6.5.1	Power Up .....	6-6
6.5.2	Normal Operation.....	6-6
6.5.3	Manually Initiated .....	6-7
6.6	Troubleshooting.....	6-8
6.7	Replacement Parts List.....	6-9
 <b>Illustration No.</b>		
Figure 1.2-1	Model 2900 Sampler.....	1-2
Figure 1.2-2	Disassembled Sampler.....	1-4
Figure 1.2-3	12 Bottle Base Section .....	1-5
Figure 1.2-4	Composite Container and Locating Insert.....	1-5
Figure 2.1-1	24 Bottle Tub.....	2-2
Figure 2.1-2	12 Bottle Tub.....	2-3
Figure 2.1-3	Latch on Stainless Steel Retaining Ring.....	2-3
Figure 2.1-4	Suction Line Assemblies.....	2-6
Figure 2.1-5A	Polypropylene Strainer with Debris Deflector in Place.....	2-7
Figure 2.1-5B	Stainless Steel Strainer.....	2-8
Figure 2.1-5C	Polypropylene Strainer with Debris Deflector .....	2-8
Figure 2.1-6	Sampler Connections.....	2-16

## Model 2900 Sampler

Illustration No.	Title	Page No.
Figure 2.2-1	Model 2900 Control Panel.....	2-20
Figure 2.2-2	Display Modes.....	2-24
Figure 2.2-2	Display Modes (continued).....	2-25
Figure 2.2-2	Display Modes (continued).....	2-26
Figure 3.2-1	Removal of the Pump Tube .....	3-4
Figure 3.2-2	Model 2900 Pump with Outer Case Half Removed.....	3-4
Figure 3.2-3	Installation of the Pump Tube .....	3-5
Figure 3.3-1	Attaching the Stainless Steel Strainer to the Teflon Suction Line .....	3-7
Figure 3.3-2	Installation of Tube Locating Strap.....	3-8
Figure 3.3-3	Placement of the Locating Insert in a 12 Bottle Tub.....	3-8
Figure 3.4-1	Control Box Internal Dessicant .....	3-9
Figure 4.1-1	Locking the Sampler.....	4-1
Figure 5.1-1	Interior View of the Control Box Lower Section .....	5-2
Figure 5.2-1	Main Circuit Board Schematic Diagram .....	5-7
Figure 5.2-2	Power Supply Circuit Board Schematic Diagram.....	5-8
Figure 5.2-3	Case Schematic Diagram .....	5-9
Figure 5.2-4	Main Circuit Board Assembly.....	5-10
Figure 5.2-5	Power Supply Circuit Board Assembly.....	5-10
Figure 6.1-1	Nicad Battery and Power Pack Fuse Replacement.....	6-2
Figure 6.2-1	Removing the Control Box .....	6-2
Figure 6.4-1	View of the Underside of the Control Box Cover .....	6-4
Figure 6.4-2	Main Circuit Board.....	6-4
Figure 6.4-3	Control Box Tray Removal .....	6-5
Figure 6.4-4	Power Circuit Board Removal.....	6-5
Figure 6.4-5	Distributor Gear Case Removal.....	6-5

Table No.	Title	Page No.
Table 1.3-1	Controls, Indicators, and Connectors.....	1-6
Table 1.4-1	Technical Specifications .....	1-7
Table 2.1-1	Hazardous Gases.....	2-12
Table 2.1-1	Hazardous Gases (continued).....	2-13
Table 2.2-1	Sampler Error Messages .....	2-28
Table 6.6-1	Model 2900 Troubleshooting Guide.....	6-10

### Trademarks

Teflon® is a registered trademark of DuPont de Nemours, E. I., & Co.  
 Noryl™ is a trademark of General Electric Co.

**Model 2900 Sampler**





# MODEL 2900

## CHAPTER 1 - INTRODUCTION

**1.0 Introduction** - The first chapter of the Model 2900 Instruction Manual provides a general introduction to the sampler. It consists of a brief discussion of the organization of the manual, an overall description of the sampler, and a list of technical specifications.

**1.1 Manual Organization** - The purpose of this manual is to provide the user, in a clear and concise manner, with the information necessary to operate, maintain, and service the Model 2900 Sampler. To accomplish this purpose, the manual is organized into six chapters.

- Chapter 1 is a general introduction to the sampler.
- Chapter 2 concerns preparation, programming, and general operation of the sampler.
- Chapter 3 contains information on routine maintenance.
- Chapter 4 concerns the major options available for use with the sampler.
- Chapter 5 is a detailed description of the construction of the sampler.
- Chapter 6 includes servicing information and a troubleshooting guide.

**1.2 Description of the Model 2900 Sampler** - The Model 2900 Sampler (see Figure 1.2-1) is a programmable liquid sampler designed to collect up to 24 separate sequential (discrete) samples from a liquid source. The sampler is available with either a 24 bottle or 12 bottle base section. The sampler is also fully programmable for composite sampling. Either base section can easily be converted for composite sampling.

**Flexible Sampling Intervals** Both sequential and composite samples may be collected at equal time intervals using the sampler's internal timing circuitry or at equal flow volume intervals using flow pulse inputs from an external flow meter. In the time mode, the interval between samples may be set from 1 to 9999 minutes in one minute intervals, or, in the flow mode, the interval may be set from 1 to 9999 flow pulses in 1 pulse intervals. Sample collection may also be manually initiated at any time.

Sample volumes of up to 500 milliliters at each sample initiation may be selected in 10 milliliter increments. When the 24 bottle base section is used, samples are collected in 500 ml polyethylene sample bottles. The 12 bottle base section provides 375 ml glass sample bottles with polystyrene foam lined plastic caps. Plastic bottles (500 ml) are also available for the 12 bottle base section. The plastic bottles have polypropylene lined caps. Should composite samples be required, a 1 gallon glass container with plastic lid is available. Both the 24 bottle and 12 bottle base sections accept the 1 gallon composite container. A locating insert, which can be used in either base, is required to position the 1 gallon container.

**Programming** The Model 2900's sampling program is set up using a keypad and a liquid crystal display. In the programming mode, the display "steps" the user through the sampler programming process by indicating the quantity (for example, sample volume) to be set. The desired quantity is then entered on the twenty-four position keypad and simultaneously shown on the display. In this way, all of the information necessary to set up the desired sampling program may be quickly and easily entered. In operation, the display shows the status of the sampling program; for example, the time remaining until the next sample, the current bottle number, the number of composite samples, etc.

**Features** A standard feature of the Model 2900 is a bottles per sample or samples per bottle multiplexer. When the 24 bottle mode is used, up to 24 bottles to be filled at each sampling interval. When the 12 bottle mode is used, up to 12 bottle can be filled at each sampling interval. In both modes, up to ten samples can be placed in each sample bottle. Also standard is a sample volume calibration mode. The volume of sample liquid delivered may be set on the keypad, or may be calibrated for special applications such as extra long suction lines or a suction line precondition by sample liquid. The sampler also features a software program lock which prevents the sampler's program from being changed by unauthorized personnel.

MODEL 2900

Figure 1.2-1 Model 2900 Sampler

Optional Suspension  
Harness

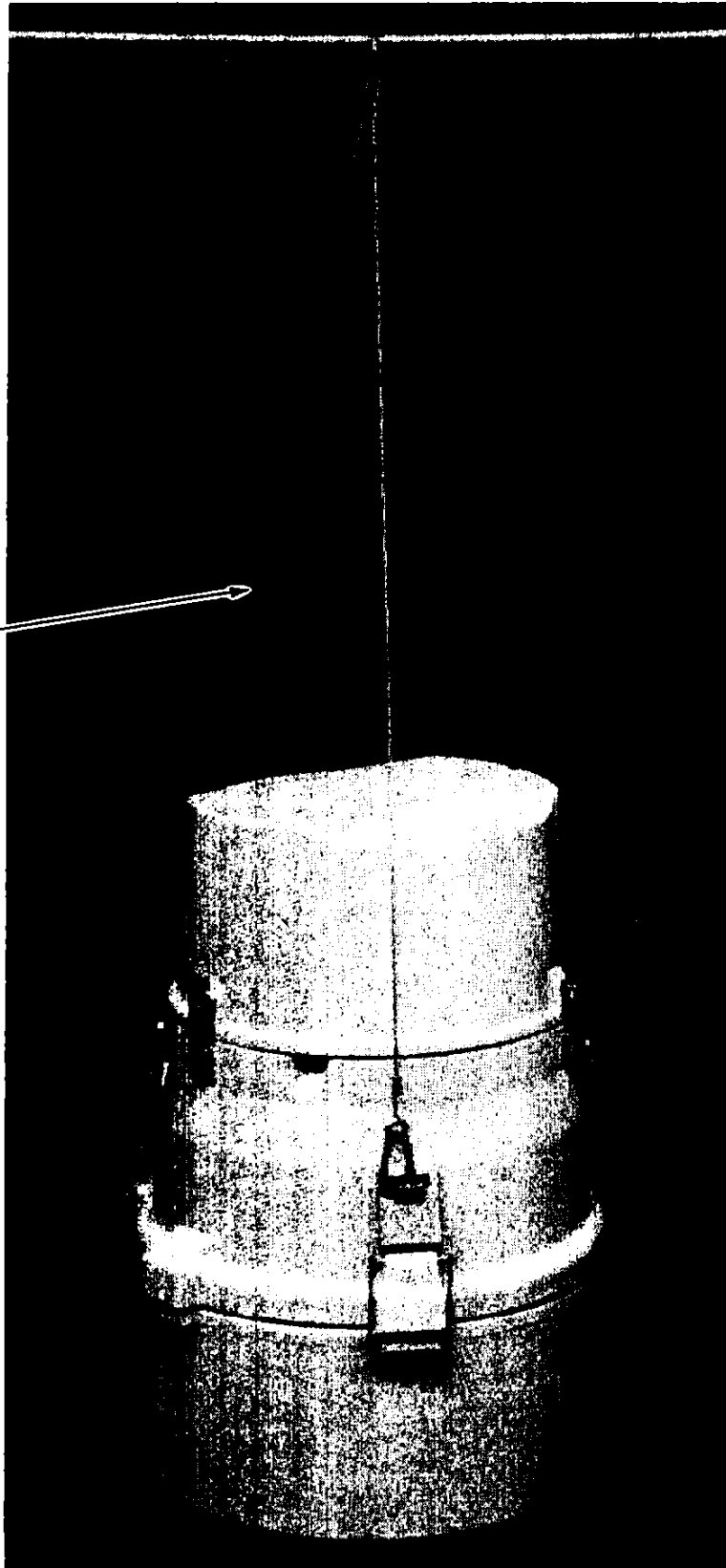

## MODEL 2900

### Pumping

The Model 2900 Sampler uses the Isco peristaltic pump system to transport the sample from the source to the sample bottle. The sample is under pumped flow at all times; there are no metering chambers or gravity-fed internal tubing. The only materials in contact with the sample are the vinyl or Teflon® suction line; the polypropylene and stainless steel inlet strainer (use optional); the silicone rubber pump tubing; and the polyethylene, plastic, or glass sample bottles. Cleaning the system between sampling locations is uncomplicated and may be accomplished by simply replacing relatively inexpensive lengths of tubing. Each sampling cycle includes an air prepurge and postpurge to clear the suction line both before and after sampling.

### Construction

The sampler is designed to operate over a temperature range of 0°C to 50°C (32°F to 120°F) in ambient conditions including high humidity, rain, or dust. The electronics and mechanisms are housed in the rugged, watertight, high impact strength, 0.64 cm (1/4 in.) thick structural foam control unit enclosure. The keypad and display used to set up and monitor the sampling program are contained on the sealed top panel of the control unit. These controls are always visible and accessible to the user, and no further cover is required to seal the control unit or protect the controls. The sampler may be powered by either a 12 volt DC battery or a "line" power source. A complete list of Isco's power sources is available in the *Isco Power Products Guide*.

The Model 2900 is made up of three sections which are held together by a series of clasps. These three sections are shown in the exploded view of Figure 1.2-2; this figure shows the 24 bottle base section. Figure 1.2-3 shows the 12 bottle base section. Figure 1.2-4 shows the 1 gallon container and the locating insert.

**COVER** - The cover encloses the mechanical and electrical components of the sampler, affording them additional protection.

**CENTER SECTION** - This section pumps, meters, and distributes the desired samples. The electronic circuitry, programming controls, and mechanisms are contained in this section.

**BASE SECTION or SAMPLE BOTTLE TUB** - This tub holds the sequential or composite sample bottles and insulates the collected samples from the outside environment.

**1.3 Controls, Indicators, and Connectors** - The controls, indicators, and connectors of the Model 2900 Sampler are briefly described in Table 1.3-1. Refer to Figure 2.2-1 for a view of the controls and indicators. Refer to Figure 2.1-5 for a view of the connectors.

**1.4 Technical Specifications** - The technical specifications of the Model 2900 Sampler are found in Table 1.4-1.

**MODEL 2900**

**Figure 1.2-2 Disassembled Sampler**

Cover or Top Section

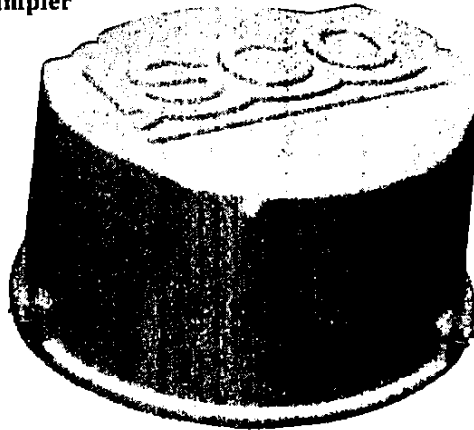

Control Box

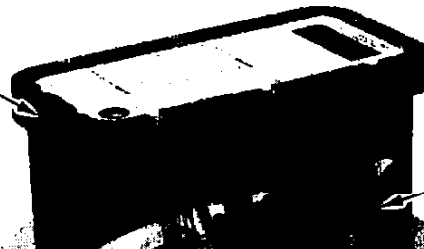

Pump Case

Rubber Draw Catch

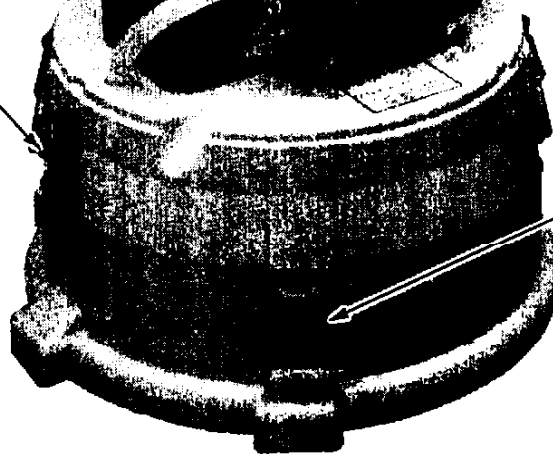

Center Section

Stainless Steel Latch

Base Section or Tub

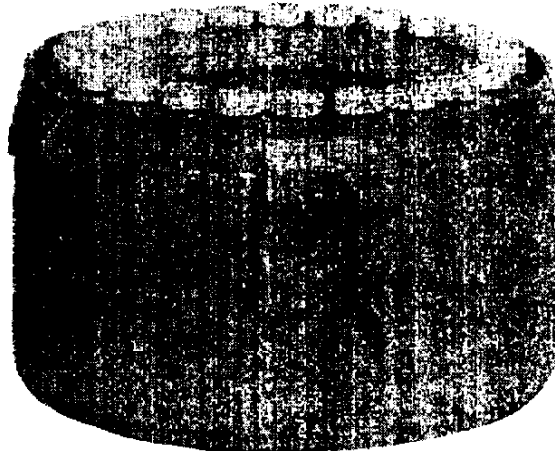

**MODEL 2900**

**Figure 1.2-3 12 Bottle Base Section**

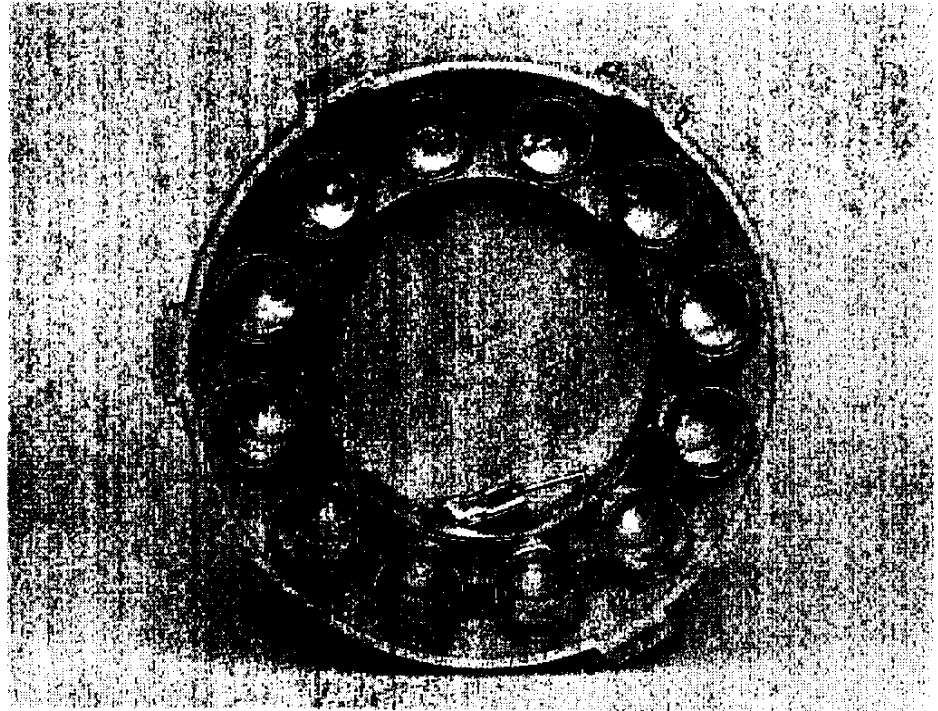

**Figure 1.2-4 Composite Container and Locating Insert**

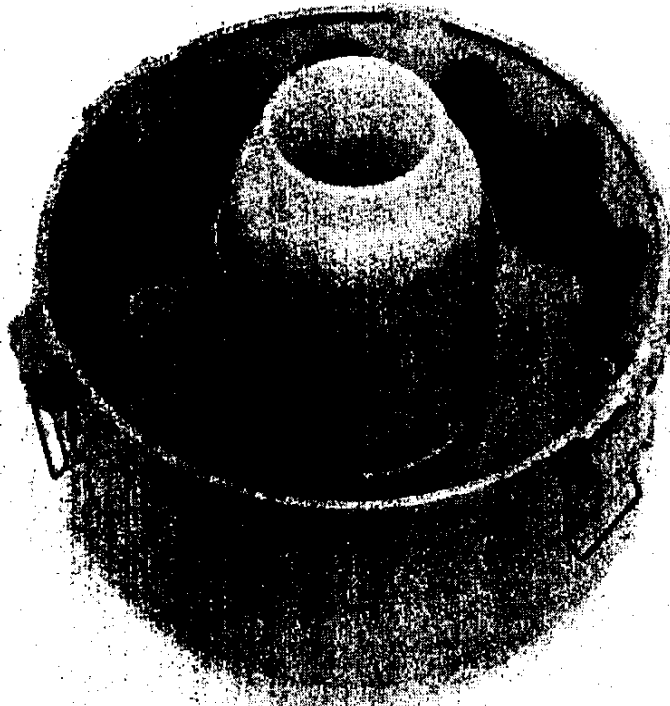

## MODEL 2900

**Table 1.3-1 Controls, Indicators, and Connectors**

CONTROLS	KEY NAME	FUNCTION
1. CONTROL keys	MANUAL SAMPLE NEXT BOTTLE PUMP JOG FWD, PUMP JOG REV, PUMP CONT. FWD, PUMP STOP	Initiates Sampling Cycle. Manually advances distributor. Manually controls action of pump. Also used in sample volume calibration.
2. NUMERIC keys	OFF, ON  0 - 9	Turns sampler off and on.  Used to enter values for the program quantity to be set.
3. PROGRAM keys	PROGRAM/STEP, ENTER VALUE, CLEAR ENTRY, START SAMPLING, HALT SAMPLING, RESUME SAMPLING	Used to control program entry and execution.

INDICATOR	READING	FUNCTION
1. Liquid Crystal Display  A. Standby State  B. Program State  C. Run State  D. Program Complete State	A. STNDBY legend on. Alternates among bottle number, time or flow pulse interval to next sample, and multiplex step. If sampling previously completed, bottle number replaced with "FULL."  B. PRGM legend on. Various  C. RUN legend on. Alternates among bottle number, time or flow pulse interval to next sample, and multiplex step.  D. "FULL"	A. Shows that the sampler is in standby state and indicates present status of the sampling program.  B. Shows the value of the program quantity step indicated as currently stored in memory or a new value as it is being entered.  C. Shows the current operational status of the sampler.  D. Indicates that the sampling program has been completed.
2. INTERNAL CASE HUMIDITY Indicator Card	Blue = Safe. Pink or White = Replace desiccant.	Indicates the relative humidity inside the control unit case.

CONNECTOR	TYPE	FUNCTION
1. 12 VDC	2 conductor plug	12 volt DC power input for sampler.
2. FLOW METER	6 conductor plug	Connector for flow meter or other accessory equipment.



**MODEL 2900**



## MODEL 2900

### CHAPTER 2 - OPERATING PROCEDURES

**2.0 OPERATING PROCEDURES** - This second chapter of the Model 2900 Instruction Manual provides the information necessary for the day-to-day operation of the sampler. Included are sections covering preparation for use, setting up a sampling program, placing the sampler into operation, and sample recovery.

**2.1 Preparation for Use** - The following sections detail the preparations required for the sampler before a sampling program is set up. They include descriptions of various preparational procedures, such as assembly and disassembly of the case, preparation of the bottle tub, attaching the suction line, connection to a power source, etc. A section providing instructions for converting a base section to accept the composite container is included.

**2.1.1 Assembly and Disassembly of the Case** - In order to prepare the sampler for use, the case must be disassembled to gain access to the various sections of the sampler. Refer to Figures 1.2-1 and 1.2-2. To gain access to the center section, unlatch the three black rubber draw catches and lift the top cover off. The catches are unlatched by simply stretching them up and out of their mating receptacles in the top cover. To gain access to the tub, unlatch the three lower stainless steel latches and lift the center section straight up. To reassemble the case, reverse the above procedures. Note that the center section and the tub are keyed to prevent incorrect assembly.

**2.1.2 Preparation of the 24-Bottle Tub** - The 24 bottle tub, shown in Figure 2.1-1, is supplied with 24 wide-mouth wedge shaped polyethylene bottles with a capacity of 500 ml each. The bottles have foamed polystyrene lined caps.

**Bottle retaining ring** The retaining ring for the bottles is a tan plastic funnel that rests on top of the slanted portion of the bottles and fits down inside the circle of bottles. It is held in place by four large "rubber bands" that are attached to the bottom of the tub. Each of these rubber bands is stretched up and hooked onto a corresponding hook located on the ring. Note that the retaining ring is necessary only if ice is used to cool the samples. The ice melt water could cause the bottles to float, interfering with the sampler's operation. If ice is used, the retaining ring is needed to prevent this. However, if ice is not used, the retaining ring is not necessary, as the wedge shape of the bottles firmly holds them in place.

**Bottle fill order** The order in which the bottles are filled by the Model 2900 is indicated on the floor plate the 24 bottle tub (Figure 2.1-1). This plate is numbered 1 through 24. Each number corresponds to one of the 24 bottles.

**Tub preparation** The sample bottle tub is prepared by first disassembling the case as described in section 2.1.1, separating the tub from the rest of the sampler. The sampler is shipped with the sample bottles in place. For the initial use, the only preparation necessary will be to remove the bottle caps. These bottle caps can be stored in the center of the tub, if ice is not used. For subsequent use, the sample bottles are removed by removing the bottle retaining ring first. Remove the tan plastic retaining ring (Figure 2.1-1) from the tub by pulling up on each of the rubber bands, disconnecting them from the hooks on the ring. Then lift the ring out and remove the full bottles. Place the new bottles in the tub as shown in Figure 2.1-1. Finally replace the bottle retaining ring. Take care that all bottles are fitted properly into the base before replacing the bottle retaining ring.

---

#### NOTE

---

**All 24 bottles must be installed in the tub to assure that they are properly held in place.**

---

## MODEL 2900

Figure 2.1-1 24 Bottle Tub

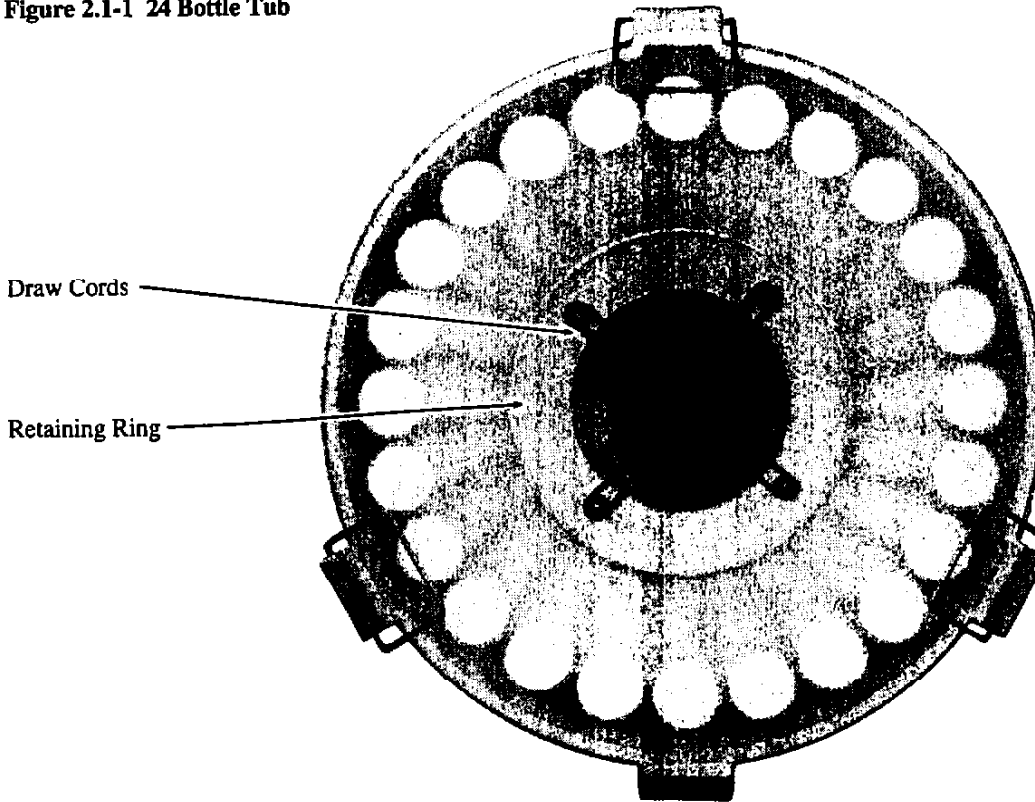

**2.1.3 Preparation of the 12 Bottle Tub** - The 12 bottle tub, shown in Figure 2.1-2, is supplied with 12 cylindrical 375 ml glass bottles or 12 plastic bottles with a capacity of 500 ml. The 375 ml glass bottles have polystyrene lined plastic caps. The plastic bottles have polypropylene lined caps.

**Bottle retaining ring** The retaining ring for the bottles is a stainless steel band that fits down inside the circle of bottles. It expands outwardly to hold the bottles firmly against the interior wall of the base. Remove the retaining ring from the base by loosening the latch and lifting the ring out of the base. Figure 2.1-2 shows the retaining ring.

**Adjusting the Retaining Ring** The 12 bottle retaining ring is designed to retain both the glass and plastic bottles without adjustment. However, the diameter of the ring can be adjusted by changing the length of the latching bolt in the latch. To adjust the diameter of the ring, first loosen the lock nut at the base of the bolt. Refer to Figure 2.1-3. Next, loosen or tighten the bolt until the diameter of the latched ring is correct. Secure the bolt into position by tightening the lock nut.

Use caution when adjusting the ring. If the ring is too small, it will not hold the bottles in position. The plastic bottles must be compressed slightly to hold them firmly in place. However, if the ring is too large when latched and presses too tightly against the bottles, it will deform the plastic bottles excessively and decrease their capacity. Under extreme conditions, the ring may break the glass bottles.

**Bottle fill order** The order in which the bottles are filled by the Model 2900 is indicated on the outer rim of the 12 bottle tub (Figure 2.1-2). Each number corresponds to one of the 12 bottles.

**Tub preparation** The sample bottle tub is prepared by first disassembling the case as described in section 2.1.1, separating the tub from the rest of the sampler. The sampler is shipped with the sample bottles in place. For the initial use, the only preparation necessary will be to remove the bottle caps. These bottle caps can be stored in the center of the tub, if ice is not used. For subsequent use, the sample bottles are removed by removing the bottle retaining ring first.

## MODEL 2900

Remove the stainless steel retaining ring (Figure 2.1-2). Then, lift the ring out and remove the full bottles. Place the new bottles in the tub as shown in Figure 2.1-2. Finally replace the bottle retaining ring when all bottles are fitted properly into the base.

---

### NOTE

---

All 12 bottles must be installed in the tub to assure that they are properly held in place.

---

Figure 2.1-2 12 Bottle Tub

Stainless Steel Retaining Ring

To remove the ring, disengage the latch and lift ring out of the tub.

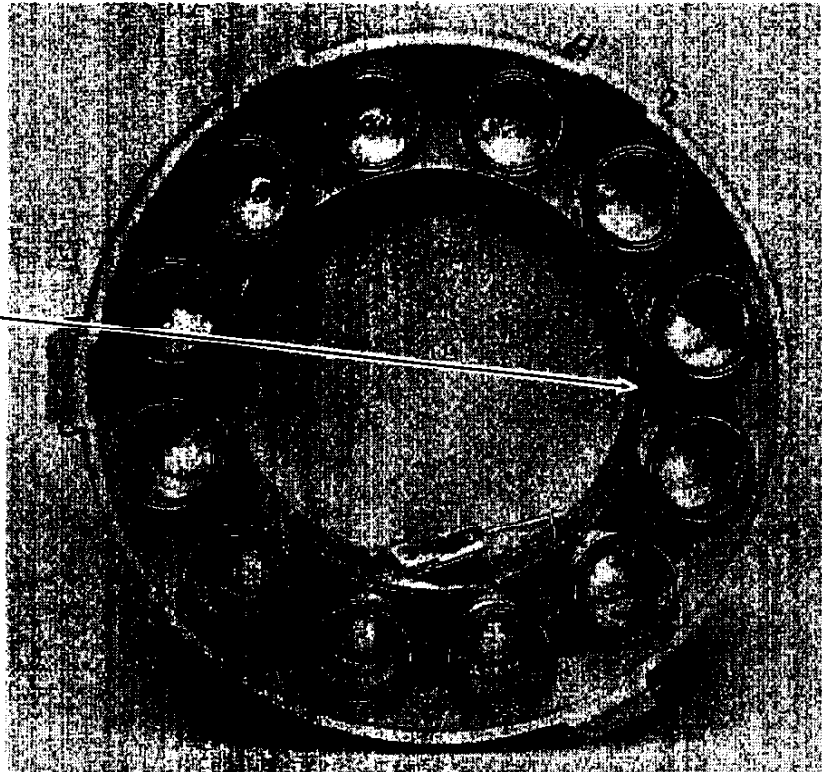
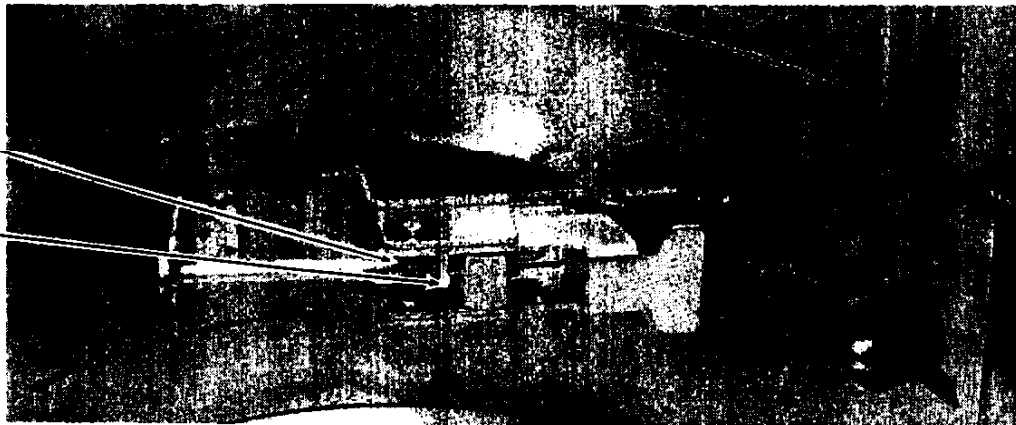

Figure 2.1-3 Latch on Stainless Steel Retaining Ring

Bolt

Lock Nut



## MODEL 2900

**2.1.4 Cooling the Samples** - For some applications, it may be necessary to keep the collected samples cooler than the ambient conditions at the site. This can be accomplished by placing cubed or crushed ice in the center of the tub. Ice can be either dumped into the empty space provided in the center of the tub or contained in a plastic bag.

For the most uniform cooling, it is best not to contain the ice but to let the resulting melt water run in between the sample bottles, creating an ice bath in the bottom of the tub. The quantity of ice used is dependent upon the required sample temperature and the ambient temperature of the sampling site. The capacity of the 24 bottle tub is approximately 4-1/2 pounds of cubed ice. Refer to Table 1.4-1 for cooling specifications.

---

### NOTE

---

**When cooling samples with ice, the melt water may cause the bottles to float when you remove the retaining ring.**

---

**Insulation** To aid in cooling the samples, both the center section and the tub have double-walled construction with polyurethane foam insulation.

**2.1.5 Attaching the Suction Line** - The suction line of the Model 2900 Sampler is the piece of tubing that extends from the sampler's pump to the liquid source. There are six standard suction lines available for use with the Model 2900. Four of the suction lines are made of vinyl tubing, and are available with two different inside diameters and two different lengths: 1/4 in. (0.64 cm) or 3/8 in. (0.94 cm) inside diameter and 10 ft. (3 m) or 25 ft. (7.5 m) length.

The other two suction lines are made of FEP Teflon with a polyethylene protective cover, and are available only in a 3/8 in. inside diameter with lengths of 10 and 25 ft. The thin polyethylene cover over the 0.02 in. (0.051 cm) wall Teflon tubing is to prevent the Teflon liner from kinking or collapsing in service and to protect it from abrasion and damage. Note that the minimum bend radius of the Teflon suction line is four inches.

**Shipment of suction lines** The 1/4 and 3/8 inch ID vinyl suction lines are shipped from the factory with a polypropylene bodied weighted inlet strainer installed on the end of the suction line. Optional all stainless steel strainers are also available for use with the vinyl or Teflon suction lines. If a stainless steel strainer was ordered with the Teflon suction line, it will be attached to the line at the factory. For sampling from highly acidic flow streams, an all plastic strainer is available. Bulk suction line can be purchased without strainers.

The suction lines, with strainer assembly attached, are shipped from the factory coiled in the center portion of the tub. The line-strainer assembly may be removed by disassembling the case as described in section 2.1.1.

There are slightly different procedures for attaching the three types of suction lines. These procedures are discussed in the following sections.

**2.1.5.1 1/4 Inch ID Vinyl Suction Line** - The first step in installing the 1/4 inch ID vinyl suction line is to remove the pump cover. This is done by loosening the four captivated thumbscrews indicated in Figure 2.1-4,A and pulling the outer pump case straight away from the control box. Loosen the lower clamp and slide the pump tubing guide and clamp assembly up the pump tube. Insert the end of the suction tube in which the stainless steel ferrule is installed into the end of the pump tube approximately 1/2 inch (1.3 cm), as shown in Figure 2.1-4,A. Next, slide the pump tubing guide and clamp assembly down over this junction so that the clamp can be tightened on the stainless steel ferrule and tighten the clamp.

Now the pump tubing guide and clamp assembly can be replaced in the inner pump case half so that its groove mates with the semicircular opening in the pump case. Slip the pump tube under the rollers so that the pump tubing does not interfere with the installation of the outer pump case half. Replace the outer pump case half so that the grooves of the pump tubing guide and clamp assembly fit properly into both halves of the pump, and tighten the four thumbscrews.

## MODEL 2900

**Removal** For instructions pertaining to the removal of the suction line and replacement of the suction tubing refer to section 3.3.1.

**2.1.5.2 3/8 Inch ID Vinyl Suction Line** - The installation procedure for the 3/8 inch ID vinyl suction line is similar to that used for the 1/4 inch ID vinyl suction line, except that the suction line does not fit directly into the pump tubing. Instead, a longer 3/8 inch ID stainless steel ferrule is installed in the suction line to connect it to the pump tube.

To install the 3/8 inch ID vinyl suction line, follow the same procedure as for the 1/4 inch ID suction line. However, instead of inserting the entire suction line and ferrule, insert only the portion of the ferrule extending out of the end of the suction line into the pump tube until the ends of the two tubes are touching, as shown in Figure 2.1-4,B. The pump tubing guide and clamp assembly is then tightened to secure the pump tube to the stainless steel ferrule. The remainder of the installation is the same as for the 1/4 inch ID vinyl suction line. An additional clamp, as shown in Figure 2.1-4,B, is provided to secure the suction line to the ferrule.

**Removal** For instructions pertaining to the removal of the suction line and replacement of the suction tubing, refer to section 3.3.2.

**2.1.5.3 3/8 Inch ID Teflon Suction Line** - The installation procedure for the 3/8 inch ID Teflon suction line is similar to that for the 1/4 inch ID vinyl line. The Teflon suction line is simply slipped inside the silicone rubber pump tube, as shown in Figure 2.1-4,C. It is not necessary or desirable to strip the polyethylene cover off the Teflon tubing prior to inserting it into the pump tube. Wetting the outside of the suction line may aid the insertion.

**Removal** For instructions pertaining to the removal of the suction line and replacement of the suction tubing, refer to section 3.3.3.

**2.1.6 Placement of the Suction Line and Intake** - When placing the suction line from the sampler to the sampling point, it is important to route the line so that it is always sloped downhill. This will insure that the suction line drains completely when the peristaltic pump reverses to purge the suction line of the liquid. Otherwise, cross-contamination of samples could occur. Also, when the sampler is used in weather near freezing, it is important to have maximum draining of the suction line to minimize the possibility of a clogged line due to freezing of any liquid in the line.

**Suction line length recommendations** As a general practice, it is advisable to use as short a line as is consistent with the sampling application. This will aid in the downhill routing mentioned and reduce the amount of liquid held in the suction line during the purge cycle caused by loops of coiled suction line. A shorter suction line will also conserve battery energy. Refer to section 2.2.6.1 for instructions on the use of nonstandard length suction lines.

**Inlet strainers** The 1/4 and 3/8 inch ID vinyl suction lines are shipped from the factory with a polypropylene bodied weighted inlet strainer installed on the end of the suction line, as shown in Figure 2.1-5,A. Optional all stainless steel strainers are also available for use with the vinyl or Teflon suction lines. Figure 2.1-5,B shows the stainless steel strainer. For sampling from highly acidic flow streams, an all plastic strainer is available

The purpose of the strainer is to prevent solid particles over a certain diameter from entering and clogging the suction line. The strainer supplied with the 1/4 inch ID suction line has 15/64 inch (.56 cm) diameter holes, preventing any particles larger than this from entering into the strainer, while the strainer supplied with the vinyl 3/8 inch ID suction line has 23/64 inch (.91 cm) diameter holes in it for the same purpose. The use of the strainer is recommended for bottom sampling or sampling from streams where large solid particles are present.

MODEL 2900

Figure 2.1-4 Suction Line Assemblies

A. 1/4" Vinyl Suction Line

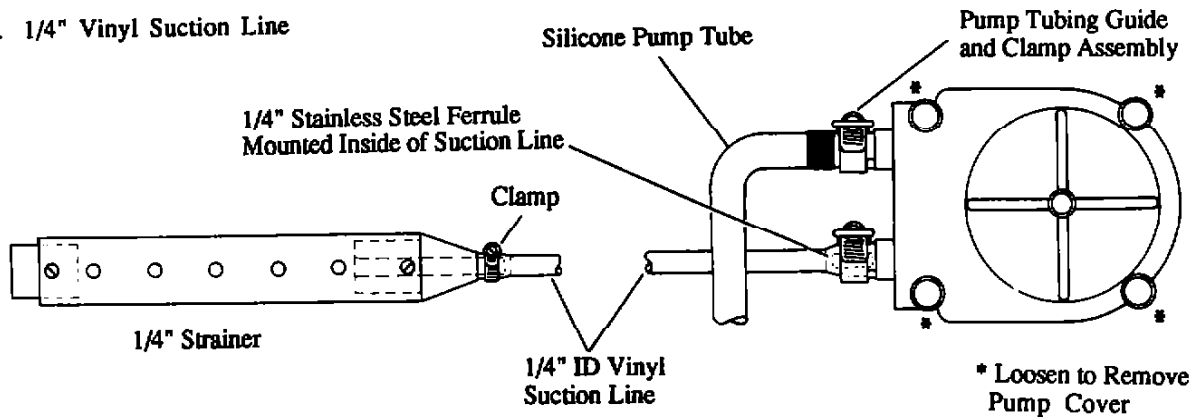

B. 3/8" Vinyl Suction Line

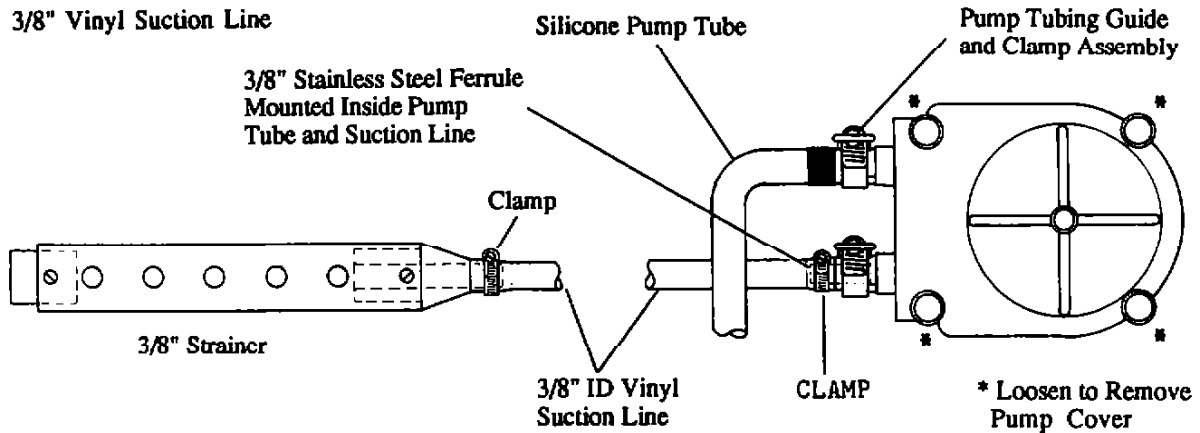

C. 3/8" Teflon Suction Line

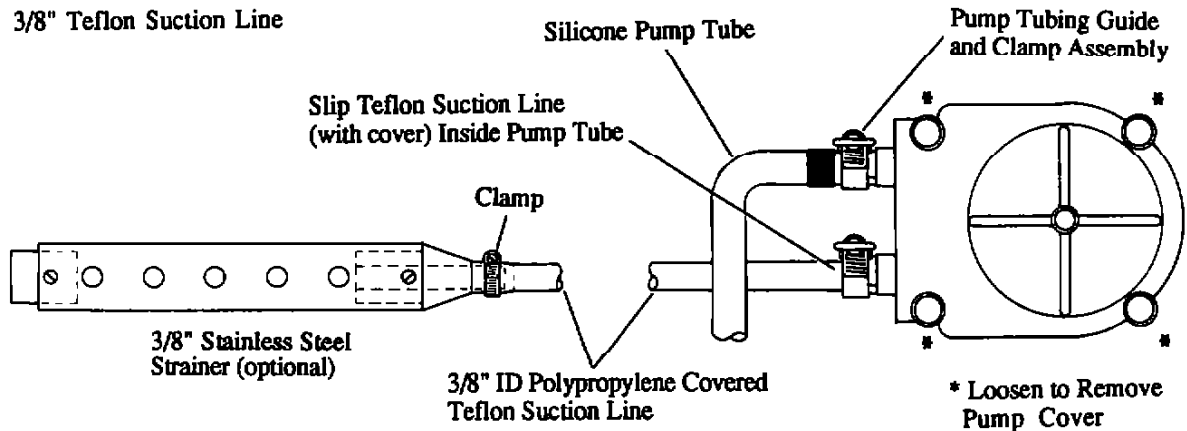

## MODEL 2900

**Use of strainer optional**      However, the use of the weighted strainer is optional. Some field investigation results indicate that, particularly when heavy suspended solids are involved and flow stream velocities are significant, more representative samples are obtained without the strainer. If the strainer is not used, it is recommended that a short piece of thin walled aluminum tubing be attached to the end of the suction line and the tubing anchored in the flow stream so that the inlet is oriented upstream. The thin wall will provide minimum disturbance of the flow stream during sampling, and aluminum ions are usually not of concern in subsequent analysis.

**Prepurge**      Whether the strainer is used or not, the prepurge cycle of the Model 2900 Sampler should be sufficient to remove any debris which may collect over the strainer or tubing entrance during periods between sampling cycles.

**Intake placement**      In either case, the placement of the sampler intake is vital to assure the collection of representative samples. The intake (either the strainer or tubing only) should be placed in the main flow and not in an eddy or at the edge of flow. The vertical position of the intake in the flow is also important. An intake at the bottom may result in excess heavy solids and no floating materials, while placement at the top may result in the opposite. Judgment must be exercised in placing the intake according to the type of sample to be collected.

The suction line tends to float in deep flow streams, dislodging the line and strainer. The chart below shows the maximum depths you can submerge the lines and strainers without risks of floatation. At depths exceeding the safe limits shown in the table, anchor the line and strainer securely.

Strainer	Maximum Depth for:		
	1/4" Vinyl Line	3/8" Vinyl Line	3/8" Teflon Line
Stainless Steel	-----	22 feet	15 feet
Low-Flow Stainless Steel	14 feet	7 feet	-----
Polypropylene	22 feet	11 feet	-----
CPVC	-----	4 feet	-----

**Figure 2.1-5A Polypropylene Strainer with Debris Deflector in Place**



## MODEL 2900

**Figure 2.1-5B Stainless Steel Strainer**



**2.1.6.1 Replacing the Suction Line on the Strainer** - A debris deflector prevents debris from accumulating on the hose clamp which attaches the strainer to the vinyl line. The 3/8 inch polypropylene strainer is shipped with the line attached and the debris deflector in place.

To replace the line on the strainer:

1. Push the deflector back up the line to expose the hose clamp. See Figure 2.1-5,C.
2. Loosen the clamp and pull the line from the strainer's ferrule.
3. Remove the deflector from the old line and thread it on the new line.
4. Thread the hose clamp on the new line.
5. Slip the line onto the ferrule and secure it with the hose clamp.
6. Push the debris deflector down the vinyl line and onto the strainer. Figure 2.1-5,B shows the deflector in place.

**Figure 2.1-5C Polypropylene Strainer with Debris Deflector**

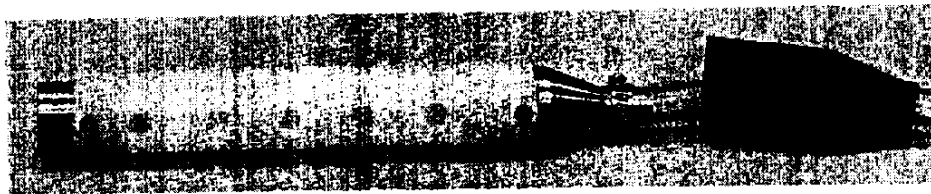



## MODEL 2900

**2.1.7 Placement of the Sampler** - The following sections describe the placement and installation of the Model 2900 at the sampling site. The first section describes safety procedures while the second section discusses general installation details.

**2.1.7.1 Safety Procedures** - In the field installation of the Model 2900, the safety of the personnel involved should be the foremost consideration. No project is so important or deadline so critical as to justify the risk of human life.

The following two sections present safety procedures applicable to working in and around manholes and sewers. The first, section 2.1.7.1.1, presents some general safety procedures. The second section, 2.1.7.1.2, addresses the special problem of lethal atmospheres in sewers.

---

### WARNING

---

The 2900 Sampler has not been approved for use in hazardous locations as defined by the National Electrical Code.

---

---

### CAUTION

---

*Before any sampler is installed, the proper safety precautions must be taken. The following discussion of safety procedures is only a general guideline. Each situation in which you install a sampler varies. You must take into account the individual circumstances of each installation.*

*Additional safety considerations, other than those discussed here, may be required. Check applicable guidelines, codes, and regulations of federal, state, city, and county agencies.*

---

**2.1.7.1.1 General Safety Procedures** - The following procedures are those used by Black & Veatch, a respected consulting firm, and are published here by their kind permission.

"Field personnel must keep safety uppermost in their minds at all times. When working above ground, rules of common sense and safety prevail. However, when entering manholes, strict safety procedures must be observed. Failure to do so could jeopardize not only your own life, but also the lives of other crew members.

**"1. Hazards.** There are many hazards connected with entering manholes. Some of the most common hazards are:

**"Adverse Atmosphere.** The manhole may contain flammable or poisonous gases or the atmosphere may be deficient in oxygen. Forced ventilation may be necessary.

**"Deteriorated Rungs.** Manhole steps may be corroded and not strong enough to support a man. It may be difficult to inspect the rungs because of poor lighting.

**"Traffic.** Whenever manholes are located in the traveled way, barricades and warning devices are essential to direct traffic away from an open manhole.

**"Falling Object.** Items placed near the manhole opening may fall and injure a worker in the manhole.

**"Sharp Edges.** Sharp edges of items in or near a manhole may cause cuts or bruises.

**"Lifting Injuries.** Unless proper tools are used to remove manhole covers, back injuries or injuries to hands or feet may result.

## MODEL 2900

**"2. Planning.** Advance planning should include arrangements for test equipment, tools, ventilating equipment, protective clothing, traffic warning devices, ladders, safety harness, and adequate number of personnel. Hasty actions may result in serious injuries. Time spent in the manhole should be kept to a minimum.

**"3. Adverse Atmosphere.** (Refer to Table 2.1-1.) Before entering a manhole, tests should be made for explosive atmosphere, presence of hydrogen sulfide, and oxygen deficiency. Since combustible or toxic vapors may be heavier than air, the tests on the atmosphere must be run at least 3/4 of the way down the manhole.

"Whenever adverse atmosphere is encountered, forced ventilation must be used to create safe conditions. After the ventilating equipment has been operated for a few minutes, the atmosphere in the manhole should be retested before anyone enters the manhole.

"When explosive conditions are encountered, the ventilating blower should be placed upwind to prevent igniting any gas that is emerging from the opening. When a gasoline engine blower is used, it must be located so that exhaust fumes cannot enter the manhole.

"If testing equipment is not available, the manhole should be assumed to contain an unsafe atmosphere and forced ventilation must be provided. It should never be assumed that a manhole is safe just because there is no odor or the manhole has been entered previously.

**"4. Entering Manholes.** Since the top of the manhole is usually flush with the surrounding surface, there may not be anything for the person who is entering the manhole to grab on to steady himself. Persons who are entering manholes should not be permitted to carry anything in their hands as they enter the manhole, to ensure that their hands will be free to hold on or grab if they slip. A good method for entering a manhole is to sit on the surface facing the manhole steps or ladder, with the feet in the hole and the arms straddling the opening for support. As the body slides forward and downward, the feet can engage a rung, and the back can rest against the opposite side of the opening. If there is any doubt about the soundness of the manhole steps, a portable ladder should be used.

"A person should never enter a manhole unless he is wearing personal safety equipment, including a safety harness and a hard hat. Two persons should be stationed at the surface continuously while anyone is working inside a manhole, to lift him out if he is overcome or injured. One man cannot lift an unconscious man out of a manhole. The persons stationed at the surface should also function as guards to keep people and vehicles away from the manhole opening. To avoid a serious injury, a person should not be lifted out of a manhole by his arm unless it is a dire emergency.

"When more than one person must enter a manhole, the first person should reach the bottom and step off the ladder before the next one starts down. When two men climb at the same time, the upper one can cause the lower one to fall by slipping or stepping on his fingers.

**"5. Traffic Protection.** In addition to traffic cones, markers, warning signs, and barricades, a vehicle or a heavy piece of equipment should be placed between the working area and oncoming traffic. Flashing warning signals should be used to alert drivers and pedestrians. Orange safety vests should be worn by personnel stationed at the surface when the manhole is located in a vehicular traffic area.

**"6. Falling Object.** All loose items should be kept away from the manhole opening. This applies to hand tools as well as stones, gravel and other objects.

## MODEL 2900

**"7. Removing the Covers.** Manhole covers should be removed with a properly designed hook. Use of a pick ax, screwdriver, or small pry bar may result in injury. A suitable tool can be made from 3/4 inch round or hex stock. Two inches of one end should be bent at a right angle and the other end should be formed into a D-handle wide enough to accommodate both hands. Even with this tool, care must be exercised to prevent the cover from being dropped on the toes. The two inch projection should be inserted into one of the holes in the cover, the handle grasped with both hands, and the cover lifted by straightening the legs which have been slightly bent at the knees.

**"8. Other Precautions.** Other precautions which should be taken when entering a manhole are:

Wear a hard hat.

Wear coveralls or removable outer garment which can be readily removed when the work is completed.

Wear boots or non-sparking safety shoes.

Wear rubberized or waterproof gloves.

Wear a safety harness with a stout rope attached.

Do not smoke.

Avoid touching yourself above the collar until you have cleaned your hands.

**"9. Emergencies.** Every member of the crew should be instructed on procedures to be followed in cases of an emergency. It is the duty of each crew chief to have a list of emergency phone numbers, including the nearest hospital and ambulance service, police precinct, fire station, and rescue or general emergency number.

**"10. Field Equipment.** The following equipment will be available for use:

Blowers	Hard Hats	Gloves"
Breathing apparatus	Harnesses	
Coveralls	Manhole irons	
First aid kits	Pick axes	
Emergency flashers	Rain slickers	
Flashlights	Ropes	
Mirrors	Safety vests	
Gas detectors	Traffic cones	
Gas masks	Waders	

MODEL 2900

Table 2.1-1  
Hazardous Gases

Gas	Chemical Formula	Common Properties	Specific Gravity or Vapor Density Air = 1	Physiological Effect*	Max. Safe 60 Min. Exposure ppm.	Max Safe 8 Hr. Exposure ppm	Explosive Range (% by vol. in air.) Limits lower/upper	Likely Location of Highest Concentration	Most Common Sources	Simplest and Cheapest Safe Method of Testing
Ammonia	NH <sub>3</sub>	Irritant and poisonous. Colorless with characteristic odor.	0.60	Causes throat and eye irritation at 0.05%, coughing at 0.17%. Short exposure at 0.5% to 1% fatal.	300 to 500	85	16 25	Near top. Concentrates in closed upper spaces.	Sewers, chemical feed rooms.	Detectable odor at low concentrations.
Benzene	C <sub>6</sub> H <sub>6</sub>	Irritant, colorless, anesthetic.	2.77	Slight symptoms after several hours exposure at 0.16% to 0.32%. 2% rapidly fatal.	3,000 to 5,000	25	1.3 7.1	At bottom.	Industrial wastes, varnish, solvents.	Combustible gas indicator.
Carbon Disulfide	CS <sub>2</sub>	Nearly odorless when pure, colorless, anesthetic. Poisonous.	2.64	Very poisonous, irritating, vomiting, convulsions, psychic disturbance.	—	15	1.3 44.0	At bottom.	An insecticide.	Combustible gas indicator.
Carbon Dioxide	CO <sub>2</sub>	Asphyxiant. Colorless, odorless. When breathed in large quantities may cause acid taste. Non-flammable. Not generally present in dangerous amounts unless an oxygen deficiency exists.	1.53	Cannot be endured at 10% more than a few minutes, even if subject is at rest and oxygen content normal. Acts on respiratory nerves.	40,000 to 60,000	5,000	— —	At bottom; when heated may stratify at points above bottom.	Products of combustion, sewer gas, sludge. Also issues from carbonaceous strata.	Oxygen deficiency indicator.
Carbon Monoxide	CO	Chemical asphyxiant. Colorless, odorless, tasteless. Flammable. Poisonous.	0.97	Combines with hemoglobin of blood. Unconsciousness in 30 min. at 0.2% to 0.25%. Fatal in 4 hr. at 0.1%. Headache in few hours at 0.02%.	400	50	12.5 74.0	Near top, especially if present with illuminating gas.	Manufactured gas, flue gas, products of combustion, motor exhausts. Fires of almost any kind.	CO Ampoules.
Carbon Tetrachloride	CCl <sub>4</sub>	Heavy ethereal odor.	5.3	Intestinal upset, loss of consciousness, possible renal damage, respiratory failure.	1,000 to 1,500	100	— —	At bottom.	Industrial wastes, solvent, cleaning.	Detectable odor at low concentrations.
Chlorine	Cl <sub>2</sub>	Irritant. Yellow-green color. Choking odor detectable in very low conc. Non-flammable.	2.49	Irritates respiratory tract. Kills most animals in a very short time at 0.1%.	4	1	— —	At bottom.	Chlorine cylinder and feed line leaks.	Detectable odor at low concentrations.
Formaldehyde	CH <sub>2</sub> O	Colorless, pungent, suffocating odor.	1.07	Irritating to the nose.	—	10	7.0 73.0	Near bottom.	Incomplete combustion of organics. Common air pollutant, fungicide.	Detectable odor.
Gasoline	C <sub>5</sub> H <sub>12</sub> to C <sub>9</sub> H <sub>20</sub>	Volatile solvent. Colorless. Odor noticeable at 0.03%. Flammable.	3.0 to 4.0	Anesthetic effects when inhaled. Rapidly fatal at 2.4%. Dangerous for short exposure at 1.1 to 2.2%.	4,000 to 7,000	1,000	1.3 6.0	At bottom.	Service stations, garages, storage tanks, houses.	1. Combustible gas indicator 2. Oxygen deficiency indicator.**
Hydrogen	H <sub>2</sub>	Simple asphyxiant. Colorless, odorless, tasteless. Flammable.	0.07	Acts mechanically to deprive tissues of oxygen. Does not support life.	—	—	4.0 74.0	At top.	Manufactured gas, sludge digestion tank gas, electrolysis of water. Rarely from rock strata.	Combustible gas indicator.
Hydrogen Cyanide	HCN	Faint odor of bitter almonds. Colorless gas.	0.93	Slight symptoms appear upon exposure to 0.002% to 0.004%. 0.3% rapidly fatal.	—	10	6.0 40.0	Near top.	Insecticide and rodenticide.	Detector tube.

\*Percentages shown represent volume of gas in air.

\*\*For concentration over 0.3%.

MODEL 2900

Table 2.1-1  
Hazardous Gases, Continued

Gas	Chemical Formula	Common Properties*	Specific Gravity or Vapor Density (Air = 1)	Physiological Effects	Max. Safe 60 Min. Exposure (ppm)	Max. Safe 8 Hr. Exposure (ppm)	Explosive Range (% by vol. in air.) Limits lower/upper	Likely Location of Highest Concentration	Most Common Sources	Simplest and Cheapest Safe Method of Testing
Hydrogen Sulfide	H <sub>2</sub> S	Irritant and poisonous volatile compound. Rotten egg odor in small concentrations. Exposure for 2 to 15 min. at 0.01% impairs sense of smell. Odor not evident at high concentrations. Colorless. Flammable.	1.19	Impairs sense of smell, rapidly as concentration increases. Death in few minutes at 0.2%. Exposure to 0.07 to 0.1% rapidly causes acute poisoning. Paralyzes respiratory center.	200 to 300	20	4.3 45.0	Near bottom, but may be above bottom if air is heated and highly humid.	Coal gas, petroleum, sewer gas. Fumes from blasting under some conditions. Sludge gas.	1. H <sub>2</sub> S Ampoule. 2. 5% by weight lead acetate solution.
Methane	CH <sub>4</sub>	Simple asphyxiant. Colorless, odorless, tasteless, flammable.	0.55	Acts mechanically to deprive tissues of oxygen. Does not support life.	Probably no limit, provided oxygen percentage is sufficient for life.	—	5.0 15.0	At top, increasing to certain depth.	Natural gas, sludge gas, manufactured gas, sewer gas. Strata of sedimentary origin. In swamps or marshes.	1. Combustible gas indicator. 2. Oxygen deficiency indicator.
Nitrogen	N <sub>2</sub>	Simple asphyxiant. Colorless, tasteless. Non-flammable. Principal constituent of air (about 79%.)	0.97	Physiologically inert.	—	—	— —	Near top, but may be found near bottom.	Sewer gas, sludge gas. Also issues from some rock strata.	Oxygen deficiency indicator.
Nitrogen Oxides	NO	Colorless	1.04	60 to 150 ppm causes irritation and coughing. Asphyxiant. 100 ppm dangerous. 200 ppm fatal.	50	10	— —	Near bottom.	Industrial wastes. Common air pollutant.	NO <sub>2</sub> detector tube.
	N <sub>2</sub> O	Colorless, sweet odor	1.53							
	NO <sub>2</sub>	Reddish-brown. Irritating odor. Deadly poison	1.58							
Oxygen (in air)	O <sub>2</sub>	Colorless, odorless, tasteless. Supports combustion.	1.11	Normal air contains 20.8% of O <sub>2</sub> . Man can tolerate down to 12%. Min. safe 8 hr. exposure, 14 to 16%. Below 10%, dangerous to life. Below 5 to 7% probably fatal.	—	—	— —	Variable at different levels.	Oxygen depletion from poor ventilation and absorption, or chemical consumption of oxygen.	Oxygen deficiency indicator.
Ozone	O <sub>3</sub>	Irritant and poisonous. Strong electrical odor. Strong oxidizer. Colorless. At 1 ppm, strong sulfur-like odor.	1.66	Max. naturally occurring level 0.04 ppm. 0.05 ppm causes irritation of eyes and nose. 1 to 10 ppm causes headache, nausea; can cause coma. Symptoms similar to radiation damage.	0.06	0.04	— —	Near bottom.	Where ozone is used for disinfection.	Detectable odor at 0.015 ppm.
Sludge Gas	—**	Mostly a simple asphyxiant. May be practically odorless, colorless.	Variable	Will not support life.	No data. Would vary widely with composition.		5.3 19.3	Near top of structure	From digestion of sludge.	See components.
Sulfur Dioxide	SO <sub>2</sub>	Colorless, pungent odor. Suffocating, corrosive, poisonous, non-flammable.	2.26	Inflammation of the eyes. 400 to 500 ppm immediately fatal.	50 to 100	10	— —	At bottom, can combine with water to form sulfurous acid.	Industrial waste, combustion, common air pollutant.	Detectable taste and odor at low concentrations.
Toluene	C <sub>7</sub> H <sub>8</sub>	Colorless. Benzene-like odor	3.14	At 200 - 500 ppm, headache, nausea, bad taste, lassitude.	200	100	1.27 7.0	At bottom.	Solvent.	Combustible gas indicator.
Turpentine	C <sub>10</sub> H <sub>16</sub>	Colorless, characteristic odor.	4.84	Eye irritation. Headache, dizziness, nausea, irritation of the kidneys.	—	100	0.8 —	At bottom.	Solvent, used in paint	1. Detectable odor at low concentrations. 2. Combustible gas indicator.
Xylene	C <sub>8</sub> H <sub>10</sub>	Colorless, flammable.	3.66	Narcotic in high concentrations. Less toxic than benzene.	—	100	1.1 7.0	At bottom.	Solvent.	Combustible gas indicator.

\* Percentages shown represent volume of gas in air.

\*\* Mostly methane and carbon dioxide with small amounts of hydrogen, nitrogen, hydrogen sulfide, and oxygen; occasionally traces of carbon monoxide.

## MODEL 2900

**2.1.7.1.2 Lethal Atmospheres in Sewers** - The following is an article written by Dr. Richard D. Pomeroy, and published in the October 1980 issue of "Deeds & Data" of the WPCF. Dr. Pomeroy is particularly well known for his studies, over a period of nearly 50 years, in the field of the control of hydrogen sulfide and other odors in sewers and treatment plants. He has personally worked in a great many functioning sewers. In the earlier years he did so, he admits, with little knowledge of the grave hazards to which he exposed himself.

"It is gratifying that the subject of hazards to people working in sewers is receiving much more attention than in past years, and good safety procedures are prescribed in various publications on this subject. It is essential that people know and use correct procedures.

"It is less important to know just what the hazardous components of sewer atmospheres are, as safety precautions should in general be broadly applicable, but there should be a reasonable understanding of this subject. It is disturbing to see statements in print that do not reflect true conditions.

"One of the most common errors is the assumption that people have died from a lack of oxygen. The human body is able to function very well with substantially reduced oxygen concentrations. No one worries about going to Santa Fe, New Mexico, (elev. 2,100 m), where the partial pressure of oxygen is equal to 16.2 percent (a normal atmosphere is about 21 percent) oxygen. When first going there, a person may experience a little "shortness of breath" following exercise. People in good health are not afraid to drive over the high passes in the Rocky Mountains. At Loveland Pass, oxygen pressure is 13.2 percent of a normal atmosphere. At the top of Mt. Whitney, oxygen is equal to 12.2 percent. Many hikers go there, and to higher peaks as well. After adequate acclimation, they may climb to the top of Mt. Everest, where oxygen is equal to only 6.7 percent.

"The lowest oxygen concentrations that I have observed in a sewer atmosphere was 13 percent. It was in a sealed chamber, near sea level, upstream from an inverted siphon on a metropolitan trunk. A man would be foolish to enter the chamber. Without ventilation, he might die, but not from lack of oxygen.

"It seems unlikely that anyone has ever died in a sewer from suffocation, that is, a lack of oxygen. Deaths have often been attributed to "asphyxiation." This is a word which, according to the dictionary, is used to mean death from an atmosphere that does not support life. The word has sometimes been misinterpreted as meaning suffocation, which is only one kind of asphyxiation.

"In nearly all cases of death in sewers, the real killer is hydrogen sulfide. It is important that this fact be recognized. Many cities diligently test for explosive gases, which is very important, and they may measure the oxygen concentration which usually is unimportant, but they rarely measure H<sub>2</sub>S. Death has occurred where it is unlikely that there was any measurable reduction in the oxygen concentration. Wastewater containing 2 mg/l of dissolved sulfide, and at a pH of 7.0, can produce, in a chamber with high turbulence, a concentration of 300 ppm H<sub>2</sub>S, in the air. This is considered to be a lethal concentration. Many people have died from H<sub>2</sub>S, not only in sewers and industries, but also from swamps and from hot springs. In one resort area, at least five persons died from H<sub>2</sub>S poisoning before the people were ready to admit that H<sub>2</sub>S is not a therapeutic agent. Hardly a year passes in the U.S. without a sewer fatality from H<sub>2</sub>S as well as deaths elsewhere in the world.

"The presence of H<sub>2</sub>S in a sewer atmosphere is easily determined. A bellows-and-ampoule type of tester is very satisfactory for the purpose, even though it is only crudely quantitative. When using a tester of this type, do not bring the air to the ampoule by way of a tube, as this may change the H<sub>2</sub>S concentration. Hang the ampoule in the air to be tested, with a suction tube to the bulb or bellows.

"Lead acetate paper is very useful as a qualitative indicator. It cannot be used to estimate the amount of sulfide, but it will quickly turn black in an atmosphere containing only a tenth of a lethal concentration.

## MODEL 2900

“Electrodes or other similar electrical indicating devices for H<sub>2</sub>S in air have been marketed. Some of them are known to be unreliable, and we know of none that have proved dependable. Do not use one unless you check it at frequent intervals against air containing known H<sub>2</sub>S concentrations. A supposed safety device that is unreliable is worse than none at all.

“Remember that the nose fails, too, when it comes to sensing dangerous concentrations of H<sub>2</sub>S.

“Various other toxic gases have been mentioned in some publications. It is unlikely that any person has been asphyxiated in a sewer by any of those other gases, except possibly chlorine. The vapor of gasoline and other hydrocarbons is sometimes present in amounts that could cause discomfort and illness, but under that condition, the explosion hazard would be far more serious. The explosimeter tests, as well as the sense of smell, would warn of the danger. Pipelines in chemical plants might contain any number of harmful vapors. They, too, are sensed by smell and explosimeter tests if they get into the public sewer. Such occurrences are rare.

“The attempt to instill a sense of urgency about real hazards is diluted if a man is told to give attention to a long list of things that in fact are irrelevant.

“Be very careful to avoid high H<sub>2</sub>S concentrations, flammable atmospheres, and hazards of physical injuries. Remember that much H<sub>2</sub>S may be released by the stirring up of sludge in the bottom of a structure. Obey your senses in respect to irritating gases, such as chlorine (unconsciousness comes suddenly from breathing too much). Be cautious about strange odors. Do not determine percent oxygen in the air. There is a danger that the result will influence a man's thinking about the seriousness of the real hazards. Most important, use ample ventilation, and do not enter a potentially hazardous structure except in a good safety harness with two men at the top who can lift you out.”

**2.1.7.2 General Installation Procedures** - When installing the Model 2900 Sampler at the sampling site, it should be placed on a relatively flat surface. Placement of the sampler on a steeply inclined surface may result in the sample partially missing the sample bottle opening.

**Manholes and suspension harness** The sampler is designed to fit through a circular manhole opening as small as 18 inches (46 cm) in diameter. A stainless steel cable harness is available as an option for lowering or raising the unit through a manhole. The unit may also be suspended from the same harness during operation, as shown in Figure 1.2-1.

**2.1.8 Connection to Power Source** - The Model 2900 can be supplied with power from one any 12-volt power source, including those listed in the *Isco Power Products Guide*. Refer to that manual for more information. You can also power the sampler from an external 12 volt direct current source (such as an automotive or marine battery). To power the sampler, simply connect the power-source connector to the 12 VDC connector on the sampler, shown in Figure 2.1-6.

**Internal battery** A small lithium battery is mounted inside the sampler. This battery keeps the sampler's electronic logic and timing circuitry operative when the external power source is interrupted and also maintains the sampler's program when the unit is shut off or external power is disconnected. In this way, the sampler's program sequence is not lost during a power interruption or even when the sampler is turned off. However, the internal battery will not operate the sampler's pump. The lithium battery has an expected life of five to ten years under normal use.

## MODEL 2900

**2.1.9 Connection to a Flow Meter** - As discussed in Chapter 1, the Model 2900 can collect samples on a flow proportional basis using flow inputs from an external flow meter. Electronically, the Model 2900 requires a 12 volt DC pulse or an isolated contact closure of at least 25 millisecond duration to cause a sample to be taken and/or register a flow pulse. Connection of the sampler to Isco and non-Isco flow meters is discussed in the following sections. If a connect cable is not attached to the flow meter socket on the side of the sampler control box, be sure that the protective cover is tightly screwed in place to maintain the watertightness of the unit.

**2.1.9.1 Isco Flow Meter** - Connect cables to connect the Model 2900 to an Isco flow meter can be purchased with the flow meter. To make the connection, attach the appropriate cable connector to the flow meter per directions in the flow meter instruction manual, and attach the other connector to the FLOW METER socket on the side of the sampler control box, as shown in Figure 2.1-6. Refer to the flow meter instruction manual and section 2.2.5.2 for further details.

**Figure 2.1-6 Sampler Connections**

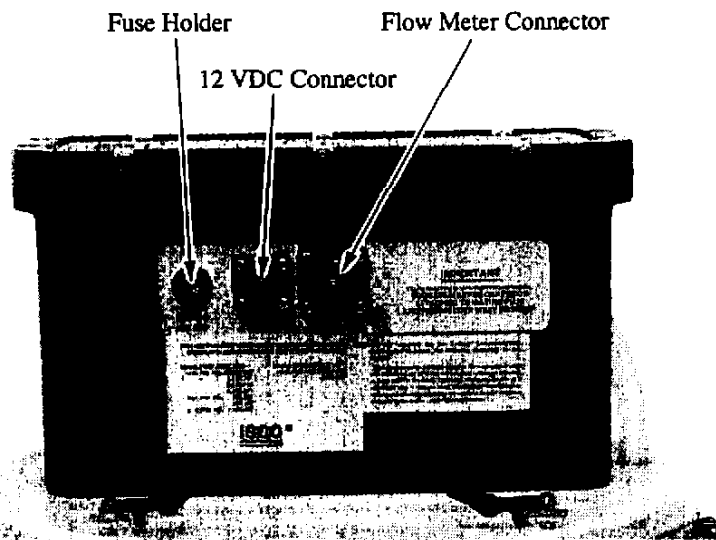

**2.1.9.2 Non-Isco Flow Meters** - Certain non-Isco flow meters can be directly interfaced with the Model 2900 Sampler. These are flow meters having an isolated contact closure type output of at least 25 millisecond duration, the frequency of the contact closures being directly proportional to total flow. A connector and cable clamp to connect a non-Isco flow meter to the Model 2900 are available from Isco, part number 68-1680-060. The isolated contact closure from the flow meter should be connected to pins A and C of the six pin connector. The connector prewired to a 22 ft. (6.7 m) cable is also available from Isco.

Attach the non-Isco flow meter connector to the FLOW METER socket on the side of the Model 2900 Sampler control box. The sampler will now accept flow pulse inputs from the flow meter. Refer to the instruction manual of the flow meter being used and section 2.2.5.2 for further information.

### Interface devices

The 2900 Sampler can also be used with flow meters having other types of outputs, for example, a 4 to 20 mA output directly proportional to flow rate. However, these flow meters require a special interface device to convert their output signal into one compatible with the 2900 Sampler. Two interfaces are available: the Type A Interface and the 4 - 20 mA Sampler Input Interface. Each interface connects to the flow meter connector on the rear of the sampler. Consult the factory for assistance in interfacing the sampler with non-Isco flow meters.

**Type A Interface**- Converts flow pulse duration output from non-Isco flow meters to acceptable flow pulses.

**4-20 mA Sampler Input Interface** - Converts 4 to 20 mA output signals from non-Isco flow meters to acceptable flow pulses.



## MODEL 2900

**2.2 Setting Up a Sampling Program** - After the preparations described in sections 2.1 through 2.1.5.2 have been completed, the Model 2900 Sampler can be programmed for automatic sample collection in a number of different modes. The following sections describe the procedures for setting up an automatic sampling program. Included are sections discussing the types of samples which may be collected, describing the sampler controls and indicators in detail, explaining standard and advanced programming techniques, and describing sample recovery procedures.

Typical sampling cycle For reference, the sequence of events in a typical sequential sampling cycle is described below:

1. The interval (either in minutes or flow pulses) since the previous sample reaches the preset value and an automatic sampling cycle is initiated.
2. The pump rotates in the reverse direction to air prepurge the suction line inlet of any accumulated debris.
3. The pump direction changes, pumping in the forward direction to fill the suction line.
4. After the suction line has been filled to the pump inlet, the sample volume measuring portion of the sampling cycle begins. The pump continues to rotate in the forward direction until the preset volume of sample has been delivered to the appropriate sample bottle.
5. The pump direction again changes, pumping in the reverse direction to air postpurge the suction line to avoid cross-contamination of samples. The pump then shuts off.
6. The distributor rotates to the position of the next sample bottle to be filled.
7. The sample interval is again being counted down from the preset value, until "zero" is reached and the cycle begins again at step 1.

This process continues until the last bottle has been filled, at which time the sampler automatically shuts off.

Peristaltic pump

Also for general reference, following is a brief description of the method by which the sample volume is determined. As discussed in section 1.2, the Model 2900 uses a peristaltic pump to transport the sample from the source to the sample bottle. When compared with other suction lift sample gathering methods, a peristaltic pump has numerous advantages: simplicity, reliability, no metering chamber required, easily cleaned, etc. However, the determination of the volumetric delivery of a peristaltic pump presents significant design problems, especially when different suction head lifts are considered. The Model 2900 addresses these problems through the use of sophisticated, patented microprocessor-based control logic.

Volumetric determination

The Model 2900 Sampler determines the volumetric delivery of its peristaltic pump by electronically counting revolutions of the pump rotor. Each revolution of the pump rotor corresponds to a certain volume of sample liquid. However, the volume of liquid delivered by one revolution of the pump rotor changes as the suction head of the pump changes and when the type of suction line being used is changed. The function of programming a suction head value into the sampler is to establish a relationship between the operating suction head and the volume delivered by one revolution of the pump rotor. The function of programming a suction line type into the sampler is to establish a relationship between the type of suction line being used and the volume delivered by one revolution of the pump rotor. Thus, for a given suction head and given type of suction line, one revolution of the pump rotor results in the delivery of a fixed, known amount of sample volume.

Volume counting

As discussed above, the sample pumping portion of a sampling cycle consists of two parts: suction line fill and sample volume delivery. The sampler "knows" the volume of the suction line being used by the diameter and length of the suction line programmed. To fill the suction line, the sampler "counts" a number of pump rotor revolutions corresponding to the volume of the suction line. After the suction line has been filled, the sample volume delivery is

## MODEL 2900

accomplished in a similar manner. The sampler "counts" a number of pump rotor revolutions corresponding to the programmed sample volume. Thus, based on a given operating suction head and a given type of suction line, the sampler fills the suction line and delivers the preselected volume to the sample bottle.

**Sample volume variation** The sample delivery process is discussed at much greater length in sections 2.2.2 and 2.2.3, below. However, it is very important to note that the volume delivered by a peristaltic pump can be influenced by a number of factors other than those discussed above. Thus, even with the sophistication of the sample volume measuring functions of the Model 2900, the volume of sample deposited in the sample bottle may vary from the programmed nominal sample volume. The repeatability of a sample volume from sample to sample (which normally is the most important consideration) will typically be within the  $\pm 10$  ml specification stated in Table 1.4-1. The wide range of sample volumes which may be programmed will allow any sample volume to be repeatably placed in the sample bottle through a trial-and-error process or by calibrating the sample volume, as discussed in section 2.2.6.1. But, the inherent potential variation between the programmed sample volume and the volume of sample actually placed in the sample bottle should be kept in mind when reading the following sections.

**2.2.1 Types of Samples** - The Model 2900 Sampler is principally designed to collect sequential (discrete) samples. However, it can easily be converted to collect composite samples. To provide a frame of reference for the following sections, the types of samples which may be collected using the Model 2900 are briefly discussed:

**Sequential time** In a sequential time sample, each individual sample collected is placed in a separate, identifiable sample bottle. Samples are collected at equal increments of time.

**Sequential flow** In a sequential flow sample, each individual sample collected is placed in a separate, identifiable sample bottle. Samples are collected at equal increments of flow volume, as measured by an associated flow meter.

**Sequential samples and multiplexing** A sequential time or flow sample represents a "snapshot" of the flow stream at a particular point in time. Note that both sequential time and flow samples may be multiplexed. In samples per bottle multiplexing, a set number of individual samples are placed into the same sample bottle. In bottles per sample multiplexing, a set number of bottles are filled at each sample interval.

**Composite time** In a composite time sample, the individual samples collected are combined ("composited") into a single container. Samples are collected at equal increments of time.

**Composite flow** In a composite flow sample, the individual samples are combined into a single container. Samples are collected at equal increments of flow volume, as measured by an associated flow meter.

**Composite** A composite time or flow sample represents an average of the characteristics of the flow stream over the total elapsed time of sampling.

## MODEL 2900

**2.2.2 Programming Overview** - To provide a general background for the discussion of the controls and indicators and sampler programming, following is an overview of the sampler's programming techniques. The sampler is programmed through the use of a 24-position keypad and a 4-character liquid crystal display (LCD) with nine additional descriptive legends. The keypad is used to enter program quantities and to control certain sampler functions. The display is used to show the program quantities being set, to indicate the operational status of the sampler, and to "step" the user through the sampler programming process by indicating the quantity to be programmed.

**Definition of programming terms** The "program quantities" are simply the quantities that define the sample and the sampling process: for example, the type of sample to be collected (sequential time), the interval between samples (30 minutes), the sample volume (150 ml), type of suction line being used (1/4" X 25'), etc. The sampler's "program" consists of a stored collection of the program quantities that completely define the sampling process, and the act of "programming" the sampler consists of establishing and storing the desired settings of the program quantities. "Running" or "executing" the sampler's program causes a series of samples to be collected according to the program quantities stored in the sampler's program.

**Sampler states** To fully understand the sampler's programming techniques, it is necessary to realize that the sampler has five basic states: off, standby, program, run, and full (program complete). In the off state, the display is blanked and none of the controls (except on) are functional. However, even in the off state, all the program quantities are retained by an internal battery. In the standby state, the sampler is waiting either to be programmed or to have the program run. In the program state the programming functions are enabled. The sampler's pump can be operated manually only in the standby and program states. In the run state, the program is being executed and the pump can only be operated under program control. In the full state (program complete), all bottles (either sequential or composite containers) have been filled according to the program and the sampler is dormant, waiting to be restarted.

**Programming process** From this overview, it can be seen that the Model 2900 Sampler is not "programmed" in the sense that a programmable calculator or home computer is programmed. The actual micro-processor-based program that controls the overall action of the sampler is built into the unit, and cannot be modified by the user. In the sense that it will be used in this manual, programming refers to the process of establishing and storing the desired settings of the program quantities. The sampler's programming process is self-prompting in that the display steps the user through the programming sequence in a logical order, indicating the program quantity to be established. The sampler will accept only appropriate values for the program quantities, and will reject any unacceptable values. Thus, the sampler's programming process is simple and straight forward.

**2.2.3 Description of Controls and Indicators** - The control panel of the Model 2900 Sampler is shown in Figure 2.2-1. The operation and use of the keypad, the liquid crystal display, and the humidity indicator are discussed in detail in the following sections.

**2.2.3.1 Keypad** - The twenty-four position keypad is used to program the sampler and to control manually certain functions of the sampler. The individual key switches that make up the keypad feature both tactile and audio feedback to assure that the key switch has been successfully actuated. When one of the key switches is pressed, the user will "feel" the resistance of the spring member in the switch, and should easily be able to note when the switch "passes over center" into the actuation point. Also, when one of the key switches is successfully actuated, an audio indicator inside the sampler will "beep" once to confirm the successful actuation of the switches.

The keypad switches are divided into three functional groups, which will be discussed individually in the following sections.

MODEL 2900

Figure 2.2-1 Model 2900 Control Panel



**1. Mode**  
 1 = 24 bottle sequential time  
 2 = 24 bottle sequential flow  
 3 = 12 bottle sequential time  
 4 = 12 bottle sequential flow  
 5 = composite time  
 6 = composite flow

**2. Interval between samples**  
 Time: 1-9999 minutes  
 Flow: 1-9999 flow pulses

**3. Delay to first/next sample**  
 1-9999 minutes

**4. Nominal sample volume**  
 1-50 in 10's of ml (sequential)  
 1-99 in 10's of ml (composite)  
 0 = calibrate mode

**5. Type of suction line**  
 1 = 1/4" x 10'    3 = 3/8" x 10'  
 2 = 1/4" x 25'    4 = 3/8" x 25'

**6. Suction head**  
 1 - 20 ft.

**7. Calibrate sample volume**

**8. Multiplex mode**  
 1 = OFF  
 2 = bottles per sample  
 3 = samples per bottle

**9. Multiplex number (sequential)**  
 bottles per sample  
 2 - 24 bottles (24 bottle)  
 2 - 12 bottles (12 bottle)  
 samples per bottle  
 2 - 10 samples per bottle

**10. Number of samples (composite)**

MANUAL SAMPLE	OFF	ON	PROGRAM STEP
NEXT BOTTLE	8	9	ENTER VALUE
PUMP JOG FWD.	6	7	CLEAR ENTRY
PUMP JOG REV.	4	5	START SAMPLING
PUMP CONT.FWD.	2	3	HALT SAMPLING
PUMP STOP	0	1	RESUME SAMPLING
CONTROL KEYS	NUMERIC KEYS	PROGRAM KEYS	

**Programming Instructions**

1. Press "ON"
2. Press "PROGRAM/STEP"
3. Enter, on numeric keypad, desired setting for program step indicated by display.
4. Press "ENTER VALUE"
5. Press "PROGRAM/STEP"
6. Repeat instructions 3, 4, and 5 for all program steps.
7. Press "START SAMPLING" to start sampling program.

Internal Case  
Humidity



## MODEL 2900

**2.2.3.1.1 CONTROL KEYS** - The left column of six keys on the keypad make up the manual control keys. These keys allow some of the sampler's functions to be manually controlled, outside of program operation. The six CONTROL keys are:

- MANUAL SAMPLE key** Pressing the MANUAL SAMPLE key of a sampler in the standby state will cause a sample to be collected according to the sampler's present program. The collection of a manual sample does not alter any of the preset program quantities (for example, the interval to the next sample); a manual sample is simply an "extra" sample outside of the normal sampling program. The sampler's logic will prevent a manual sample from being collected in a sample bottle which the sampler believes to be "full." Note that the manual sample key is functional only when the sampler is in the standby state.
- NEXT BOTTLE key** Pressing the NEXT BOTTLE key of a sampler in the standby state will cause the distributor to be indexed to the next bottle. Multiple depressions of the key will cause the distributor to be advanced a like number of bottles. Advancing the distributor past the last (24th) bottle will cause it to be reset to the first bottle position. Note that the NEXT BOTTLE key is functional only when the sampler is in the standby state.
- PUMP JOG FWD key** Pressing the PUMP JOG FWD (forward) key will cause the sampler's pump to run in the forward direction as long as the key is held down. When the key is released, the pump will stop. Note that the PUMP JOG FWD key is functional only when the sampler is in the standby state or in the program state (for calibration of sample volume as discussed in section 2.2.6.1).
- PUMP JOG REV key** Pressing the PUMP JOG REV (reverse) key will cause the sampler's pump to run in the reverse direction as long as the key is held down. When the key is released, the pump will stop. Note that the PUMP JOG REV key is functional only when the sampler is in the standby state or in the program state (for calibration of sample volume, as discussed in section 2.2.6.1).
- PUMP CONT. FWD key** Pressing the PUMP CONT. FWD (continuous forward) key will cause the sampler's pump to run continuously in the forward direction. The pump may be stopped by pressing the PUMP STOP key, as described below. Note that the PUMP CONT. FWD key is functional only when the sampler is in the standby state.
- PUMP STOP key** Pressing the PUMP STOP key will cause the sampler's pump to immediately cease pumping. Note that the PUMP STOP key is functional any time that the sampler's pump is running, regardless of whether it is running under manual or program control.

**2.2.3.1.2 NUMBER KEYS** - The center two columns of twelve keys on the keypad make up the NUMBER KEYS. These keys turn the sampler on and off, and allow program quantities to be entered. The twelve NUMERIC KEYS are:

- OFF key** Pressing the OFF key blanks the liquid crystal display, disables all keys except the ON key, and immediately interrupts any action of the sampler (pumping or movement of the distributor). Note that an internal battery maintains the program quantities even when the unit is turned off.
- ON key** Pressing the ON key of a sampler which has been turned off will reactivate the display and place the sampler into the standby state.
- Numeric keys** Pressing any of the numeric keys will cause the number entered to be shown on the display. They are used to enter program quantities into the sampler.

**2.2.3.1.3 PROGRAM KEYS** - The right column of six keys on the keypad make up the CONTROL keys. These keys are used to set up and control the execution of the sampler's program. The six CONTROL keys are:

- PROGRAM/STEP key** Pressing the PROGRAM/STEP key of a sampler in the standby state will cause the sampler to be transferred from the standby to the program state. Once the sampler is in the program state, depressing the PROGRAM/STEP key will cause the quantity shown in the display to be loaded into memory and the unit to be stepped to the next program quantity. A depression

## MODEL 2900

of the PROGRAM/STEP key after the last applicable program quantity step will cause the sampler to be returned to the standby state from the program state. Thus, the PROGRAM/STEP key is used to place the sampler into the program state and to step through the program quantities to be set.

- Implied ENTER VALUE** The PROGRAM/STEP key may also be used in place of the ENTER VALUE key (discussed below), as the PROGRAM/STEP key contains an implied enter value function. Pressing the PROGRAM/STEP key of a sampler in the full (program complete) state will cause the sampler to be transferred to the program state.
- Program scan** Depressing the PROGRAM/STEP key of a sampler in the run state will cause the sampler to be placed into a program scan mode, showing on the display the program quantity step number followed by the value of the program quantity set. This allows the settings of the program quantities to be checked without halting the sampler's program by repeatedly pressing the PROGRAM/STEP key. While the program is being scanned in this manner, the PRGM legend will be shown on the display in addition to the RUN legend. If, after a program scan has been initiated, the PROGRAM/STEP key is not pressed again, the scan mode will be terminated after approximately 60 seconds. After the last applicable program quantity has been stepped through, the sampler will return to the normal run state.
- ENTER VALUE key** Pressing the ENTER VALUE key will cause the program quantity shown on the liquid crystal display to be loaded into the sampler's memory. It should be emphasized that depressing the ENTER VALUE key does not sequence the sampler to the next program quantity. If the ENTER VALUE key is used, the unit must be sequenced by the use of the PROGRAM/STEP key. Pressing the ENTER VALUE key also restores the alternation of the display between the program quantity step number and the newly entered value. The ENTER VALUE key is also used to place a sampler in the standby state into a special program mode so that the Liquid Level Sampler Actuator mode of operation may be set, as described in section 2.2.6.2. Note that this key is functional only for a sampler in the program or standby state.
- CLEAR ENTRY key** Pressing the CLEAR ENTRY key will cause a newly entered value shown on the display to be replaced with the previously entered value. A second depression of the CLEAR ENTRY key (without an intermediate depression of one of the numeric keys) will cause the sampler to be transferred from the program to the standby state. Likewise, if no new value has been entered using the numeric keys before the CLEAR ENTRY key is pressed, the sampler will also be transferred from the program to the standby state. This is to provide the user with a means of getting out of the programming state without sequencing through all the program quantities. When the sampler is being programmed in the calibrate sample volume mode (section 2.2.6.1), in certain instances the CLEAR ENTRY key may be used to step backwards through the quantities being entered, as described in the referenced section. The CLEAR ENTRY key is also used to place a sampler in the standby state into a special program mode so that the program lock may be engaged, as described in section 2.2.6.3. Note that the CLEAR ENTRY key is functional only for a sampler in the program or standby state.
- START SAMPLING key** Depressing the START SAMPLING key of a sampler in standby or full (program complete) state will cause the distributor to be reset to the bottle number one position, and cause the sampling program to begin according to the program quantities previously set. Note that the START SAMPLING key is functional only for a sampler in the standby or full states.
- HALT SAMPLING key** Pressing the HALT PROGRAM key of a sampler in the run state will cause the sampling program which is in operation to be halted and will transfer the sampler to the standby state.
- Time incrementing continues** This allows the sampler's program to be modified, if desired. Time incrementing will continue even after the program has been halted. If the interval to the next sample reaches zero while the program is halted, no sample will be collected, the time interval to the next sample will be reset to the programmed interval, and time incrementing will continue. A missed sample will not be remembered and consequently will not be collected when the program is resumed by the RESUME SAMPLING key. Flow pulse incrementing will cease until the program is resumed. If the HALT SAMPLING key is pressed while the sampler's pump is running, the pump will immediately stop. Note that the HALT SAMPLING key is functional

## MODEL 2900

only for a sampler in the run state. The use of the HALT SAMPLING key is further discussed in section 2.2.6.3, below.

The HALT SAMPLING key can also be used to access the special programming step used to select English or metric units of measure for the sampler. Refer to section 2.2.6.3.1 for more information.

**RESUME SAMPLING key** Pressing the RESUME SAMPLING key of a sampler in the standby state will cause the sampling program as it currently exists to begin execution. The distributor will not be reset. The RESUME SAMPLING key is normally used to resume the program of a previously running sampler whose program has been interrupted by the HALT SAMPLING key. If, during the time while the program was halted, no program quantities or only the interval between samples and/or the interval to the first/next sample were changed, the sampling program will be resumed, upon depression of the RESUME SAMPLING key, at the point where it was halted, according to the program quantities currently set. If, on the other hand, any program quantities other than the interval between samples or the interval to the first/next sample were changed during the program halt, behavior of the sampler upon program resumption depends upon two factors. First, if the sampler is operating in one of the multiplex modes, and the multiplex number is something other than one, when the RESUME SAMPLING key is pressed, the distributor will advance to the next bottle and the multiplex number will be reset to one. And second, if the program was halted during a sample collection (while the pump is running), when the RESUME SAMPLING key is pressed the suction line will be purged and the distributor advanced to the next bottle. Note that the RESUME SAMPLING key is functional only for a sampler in the standby state. The use of the RESUME SAMPLING key is further discussed in section 2.2.6.3, below.

**Resumption criteria**

**2.2.3.2 Display - The 4-digit liquid crystal display (LCD) with nine additional descriptive legends is used to display the program quantities being set, to display the operational status of the sampler, and to "step" the user through the programming process in a logical manner. The nature of the display depends upon which of the five possible states the sampler is in.**

**OFF state** For a sampler in the OFF state, the display is blanked (turned off).

**STANDBY state** For a sampler in the standby state, the STNDBY (standby) legend on the display will always be on. For the sampler has been previously programmed to be in either the sequential time or sequential flow mode, the present position of the distributor or the bottle number ("XX") will alternate with the time or flow pulse interval to the next sample ("00XX"), as shown in Figure 2.2-2.A. When the bottle number is shown, the BTL# (bottle number) legend will be on; when the time or flow pulse interval is shown, either the TIME or FLOW legend (as appropriate) will be on.

If the sampler has been previously programmed to be in either of the multiplex modes of operation, the MPLX (multiplex) legend will always be on. If the sampler is operating in a multiplex samples per bottle mode, a third quantity will be added to the sequence, the multiplex step number ("X"), as shown in Figure 2.2-2.B. When the multiplex step number is shown, the MPLX (multiplex) and STEP legends will be on.

For a sampler previously programmed for the composite mode in the standby state, the STNDBY (standby) legend on the display will always be on. The time or flow pulse interval to the next sample ("00XX") will alternate with the total number of composite samples collected ("XXX"), as shown in Figure 2.2-2.C. When the time or flow pulse interval is shown, either the TIME or FLOW legend (as appropriate) will be on; when the number of composite samples collected is shown, the COMP (composite) legend will be on.

If a sequential sampling program has been previously completed (all 12 or 24 bottles filled or all composite samples taken.), when the sampler is in the standby state, the bottle number or number of composite samples taken in the alternating sequence will be replaced with the text "FULL," as shown in Figure 2.2-2.D. Note that when the distributor is moving when the sampler is in the standby state, the final destination bottle number will be shown, not the current position of the distributor.

## MODEL 2900

**Figure 2.2-2 Display Modes**

**A. Standby State (nonmultiplex mode)**

Alternates between:

STL# 14 STNDBY and

Next sample bottle number

TIME 0015 STNDBY

Time or flow pulse interval to next sample

**B. Standby state (multiplex samples per bottle mode)**

Alternates among:

STL# 14 STNDBY and

Next sample bottle number

MPLX 3 STEP STNDBY and

Next sample multiplex step number

TIME 0015 STNDBY

**C. Standby state (composite mode)**

Alternates among:

TIME 0015 STNDBY and

Time or flow pulse interval to next sample

COMP 125 and

Total number of composite samples collected

FULL

Total number of composite samples collected

**D. Standby state (sequential sampling previously completed)**

Alternates among:

FULL and

MPLX 1 STEP STNDBY and

Next sample multiplex step number

TIME 0032 STNDBY

Time or flow pulse interval to next sample

**E. Standby state (composite sampling previously completed)**

Alternates among:

TIME 0015 STNDBY and

Time or flow pulse interval to next sample

COMP 125 and

Total number of composite samples collected

FULL STNDBY

**F. Program state**

Alternates between:

TIME 2 PRGM STEP and

Program quantity step number

TIME 0060 PRGM

Value of program quantity. (For example, time interval between samples.)



MODEL 2900

Figure 2.2-2 Display Modes (continued)

G. Run state (nonmultiplex mode)

Alternates between:

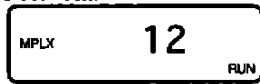

and



Next sample bottle number

Time or flow pulse interval to next sample

H. Run state (multiplex bottles per sample mode)

Alternates between:

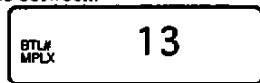

and

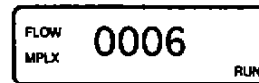

Next sample bottle number

Time or flow pulse interval to next sample

I. Run state (multiplex samples per bottle mode)

Alternates among:

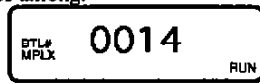

and

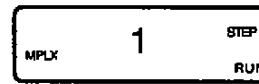

and

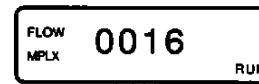

Next sample bottle number

Next sample multiplex sample number

and

Time or flow pulse interval to next sample

J. Run state (composite mode)

Alternates among:

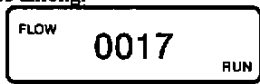

and

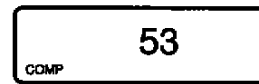

Time or flow pulse interval to next sample

Total number of composite samples collected

K. Run state (while the pump is running)

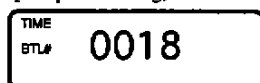

and

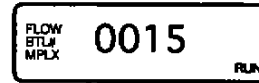

Bottle number into which sample is being placed (nonmultiplex mode)

Bottle number into which sample is being placed (multiplex mode)

L. Run state (program scan mode)

Alternates between:

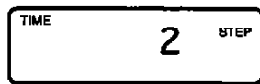

and

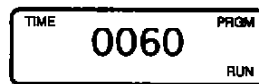

Program quantity step number

Value of program quantity (for example, time interval between sample)

M. Full state (sequential modes)



## MODEL 2900

Figure 2.2-2 Display Modes (continued)

### N. Standby state (composite mode)

Alternates among:

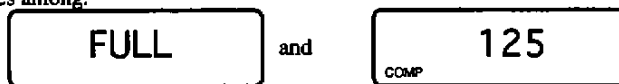

Total number of composite samples collected

If a composite sampling program has been previously completed (the composite container filled), a third quantity will be added to the alternation of the display, the text "FULL," as shown in Figure 2.2-2,E.

### PROGRAM state

For a sampler in the program state, the PRGM (program) legend on the display will always be on, and the display will initially alternate between a number which indicates the program quantity to be set (" X ") and the current value of the program quantity indicated (" XX"), as shown in Figure 2.2-2,F. The program quantity step number refers to the 10 numbered program quantity descriptions listed on the sampler's control panel directly below the display; these are discussed in detail later in this section. When the program quantity step number is shown on the display both the PRGM and STEP (program step) legends will be on. When the program quantity presently set is shown, the STEP legend will be turned off.

As soon as a new program quantity is entered on the numeric keypad, the alternating nature of the display will be halted and the new value being entered will be shown on the display. The alternation of the display between the program quantity step number and the value of the program quantity indicated will be restored when either the ENTER or PROGRAM/STEP key is pressed. Either the TIME or FLOW legend (as appropriate for the mode selected) will be on when the sampler is in the program state. If either of the multiplex modes of operation have been selected, the MPLX (multiplex) legend will be on. If the composite mode of operation have been selected, the COMP (composite) legend will also be on.

It should be noted that during the time when a new program quantity is being entered on the numeric keypad, if there is no further activity on the keypad for approximately five minutes, the alternation of the display will be restored with the previously established program quantity value being shown.

### RUN state

For a sampler in the run state, the RUN legend on the display will always be on. For a sampler programmed for sequential sampling, the display will alternate between the next sample bottle number (" XX ") and the time or flow pulse interval to the next sample ("00XX"), as shown in Figure 2.2-2,G. When the bottle number is shown, the BTL# (bottle number) legend will be on; when the time or flow pulse interval is shown, either the TIME or FLOW legend (as appropriate) will be on.

If the sampler is operating in one of the two multiplex modes, the MPLX (multiplex) legend will always be on while the sampler is in the run state. If the sampler is operating in the multiplex bottles per sample mode, the display will alternate between the bottle number and the time or flow pulse interval to the next sample, as shown in Figure 2.2-2,H. If the sampler is operating in the multiplex samples per bottle mode, a third quantity will be added to the alternating display, the next sample multiplex step number (" X "), as shown in Figure 2.2-2,I.

For a sampler previously programmed for composite sampling and operating in the run state, the RUN legend on the display will always be on. The display will alternate between the time or flow pulse interval to the next sample ("00XX") and the total number of composite samples collected (" XXX"), as shown in Figure 2.2-2,J. When the time or flow pulse interval is shown, either the TIME or FLOW legend (as appropriate) will be on; when the number of composite samples collected is shown, the COMP (composite) legend will be on.

## MODEL 2900

For a sampler programmed for sequential sampling and operating in the run state, the following displays appear. When the multiplex step number is shown, the MPLX and STEP (multiplex step) legends will be on. During the time while a sequential sample is actually being collected (that is, while the pump is running), the bottle number into which the sample is being placed will be shown on the display ("XX") and the BTL# legend will be on, as shown in Figure 2.2-2,K. Either the TIME or FLOW legend will be on as appropriate, and the MPLX legend will be on if one of the multiplex modes has been programmed.

As described in section 2.2.3.1.3, a sampler in the run state may be placed into a special program scan mode. In this mode, both the RUN and PRGM legends will be on simultaneously. The display will alternate between the program quantity step number ("X") and the current value of the program quantity indicated ("XX"), as shown in Figure 2.2-2,L. When the program quantity step number is shown on the display, the STEP legend will also be on.

FULL state	When a sequential program has been completed, the display will show the text "FULL," as shown in Figure 2.2-2,M. None of the legends will be on. When a composite program has been completed, the display will alternate between the text "FULL" and the total number of samples collected before sampling was terminated ("XXX"), as shown in Figure 2.2-2,N.
Operational error messages	The display also indicates error conditions which may occur during operation of the sampler.
Jammed pump	If the sampler's pump becomes jammed (for example, by the formation of ice in the pump tube), the display will indicate this condition with the word "HELP." The "HELP" display will be shown when the sampler attempts to run a jammed pump, either under program control or responding to the manual pump controls. To prevent injury due to unexpected actuation of the pump during servicing, the sampler will be "locked-up" as long as the "HELP" error message is shown on the display. In other words, simply unjamming the pump will not cause the pump to resume action, nor will it cause the sampling program to be restarted or allow the pump to be operated manually. The display may be cleared of the "HELP" error message and normal operation restored by turning the sampler off and back on.
Misplaced distributor	If the distributor is not in place over the proper bottle when a sampling cycle is initiated (either manually or under program control), the display will show four dashes ("----") as long as the distributor is not over the proper bottle. The pump will not run until the distributor is over the proper bottle. The "----" error message will be cleared from the display and the sample will be collected when the distributor reaches its proper position over a sample bottle.
Diagnostic routine error messages	As discussed in section 6.6, the Model 2900 automatically runs diagnostic checks on its internal RAM and PROM memory upon power up and during operation. If an error is detected during power up (refer to section 6.6.1), the display will become "stuck" on one of the following error messages: "PPPP" or "EEEE." If an error is detected during operation (refer to section 6.6.2), other error messages will also be shown in the display. In this case, the error message consists of the letters EE ("-EE-") and in some instances a number. The display will also show other quantities and possibly error messages during the manually initiated diagnostic routine, as discussed in section 6.6.3.
Low battery indication	Depending upon the circumstances, the sampler may indicate a low battery in any one of several ways. If the sampler's battery is dead or extremely low, the sampler will be completely inoperative; the display will not light and the pump will not run. If the sampler's battery is discharged, but not completely dead, the low battery condition will be indicated on the sampler's display. In this case, the display may read either "HELP," "PPPP," or "EEEE."
	Depending upon the state of discharge of the battery, the sampler's pump may also repeatedly cycle on and off during a sampling cycle. If any of these indications are present, it should be assumed that the battery is low and the sampler's battery should be replaced or recharged. However, it should be noted that the "HELP," "PPPP," or "EEEE" displays may also indicate other types of problems. If replacing or recharging the sampler's battery does not restore the normal operation of the display, refer to Table 6.7-1 for further troubleshooting instructions.

## MODEL 2900

### Program quantity steps

As mentioned, there are ten program quantity step descriptions listed on the sampler's control panel directly below the display. The program quantity step descriptions list the program quantity to be set and indicate the acceptable settings. They are numbered 1 through 10, and correspond to the program quantity step numbers (PRGM STEP) shown on the display when the sampler is in the program mode. Their purpose is to "step" the user through the sampler programming process by indicating the program quantity to be set. When the sampler is placed into the program state by pressing the PROGRAM/STEP key, PRGM STEP 1 will be shown on the display, indicating that the first program quantity (MODE) is to be set.

Subsequent depressions of the PROGRAM/STEP key will cause the unit to sequentially step through the program quantities to be set. Depending upon the type of sampling program being established certain of the program quantity steps may be skipped, as described below. When the PROGRAM/STEP key is pressed after the last program quantity has been set, the sampler will be transferred from the program to the standby state. Note that for a sampler in the program state, if there is no activity on the keypad for five minutes, the sampler will automatically be transferred from the program to the standby state.

**Table 2.2-1 Sampler Error Messages**

ERROR MESSAGE	MEANING
"HELP"	Sampler's pump jammed.
"_ _ _ _"	Distributor not in position over proper bottle at time of sample initiation.
Stuck on "PPPP."	Failed PROM check during power up.
Stuck on "EEEE."	Failed RAM check during power up.
Time or flow pulse interval to next sample replaced by "-EE-" in the normal rotation of the display	Failed PROM or RAM check while operating in the run state.
Alternates between "-EE-" and " 1."	Failed PROM check while operating in off or standby states, or in run state and subsequently placed into off or standby state.
Alternates between "-EE-" and " 2."	Failed RAM check while operating in off or standby states, or in run state and subsequently placed into off or standby state.
Alternates between "-EE-" and " 3."	Distributor time out error detected either during normal operation (standby or run states) or during manually initiated diagnostics.
Alternates between "-EE-" and " 4."	Distributor bottle 1/24 phase error detected either during normal operation (standby or run states) or during manually initiated diagnostics.
Alternates between "-EE-" and " 5."	Distributor total number of bottles error detected during manually initiated diagnostics.
Alternates between "-EE-" and " 6."	Pump rotation counting optics error detected during pumping portion of manually initiated diagnostics.

## MODEL 2900

### MODE

When PRGM STEP 1 (MODE) is shown on the display, the basic mode of sampler operation may be selected. The mode to be used is selected by entering on the keypad the number associated with the mode. The two modes available and the numbers used to select them are as follows.

- 1 = 24 bottle sequential time
- 2 = 24 bottle sequential flow
- 3 = 12 bottle sequential time
- 4 = 12 bottle sequential flow
- 5 = composite time
- 6 = composite flow

These modes of operation were briefly described in section 2.2.1, above. For example, to select a time mode of operation, the number 1 should be entered in the keypad. If MODE 1 (24 bottle sequential time) is selected, the TIME legend on the display will be on while the sampler is in the program state. If MODE 2 (flow) is selected, the FLOW legend on the display will be on. If MODE 5 (composite time) is selected, the COMP and TIME legends on the display will be on.

### INTERVAL BETWEEN SAMPLES

When PRGM STEP 2 (INTERVAL BETWEEN SAMPLES) is shown on the display, the time or flow pulse interval between samples may be selected. When the sampler is operating in the time mode (mode 1), the interval is set in minutes. The time interval between samples is selected by entering on the keypad any value between 1 and 9999 minutes. When the sampler is operating in the flow mode (mode 2), the interval is set in flow pulses (received from an external flow meter). A flow pulse is simply an electronic signal from the flow meter indicating that a certain fixed total volume of liquid has flowed past the flow meter, for example, 10,000 gallons. The flow interval between samples is selected by entering on the keypad any value between 1 and 9999 flow pulses.

### Interval and duration of sampling cycle

When setting the interval between samples, be sure that the interval selected is longer than the duration of the sampling cycle described in section 2.2. The duration of the sampling cycle will vary according to the program quantities selected, and if it is questionable, the duration may be determined by simply timing one complete cycle. For truly representative sampling, the interval between samples selected (either in minutes or the fastest anticipated flow pulse rate) should be longer than the duration of the sampling cycle established. Otherwise certain sample initiations will occur at improper times, although no sample initiations will be lost.

### DELAY TO FIRST/NEXT SAMPLE

Then PRGM STEP 3 (DELAY TO FIRST/NEXT SAMPLE) is shown on the display, the time delay to the first (or the next) sample may be selected. The time delay to the first/next sample is selected by entering on the keypad any value between 1 and 9999 minutes. This allows the user to establish a time delay to the first sample independent of the normal interval between samples, permitting the synchronization of the sampling program with real clock time or any other external event. Since time continues to advance for a sampler in the program state, the start time delay to the first sample starts at the moment the delay is entered on the keypad. If the sampler is not placed into the run state before the delay to the first sample has counted down to zero, the delay to the first sample will be automatically reset to the normal interval between samples, and the counting down process restarted.

### DELAY different

It is very important to realize that the program quantity set when PRGM STEP 3 (DELAY TO FIRST/NEXT SAMPLE) is shown on the display is different from all the other program quantities. The DELAY TO FIRST/NEXT SAMPLE step provides the user with access to the register in the sampler's memory which contains the time interval until the next sample is collected. When PRGM STEP 3 (DELAY TO FIRST/NEXT SAMPLE) is shown on the display, the time interval remaining until the next sample (which may be the first or a subsequent sample) is collected will be shown on the display and may be changed by a keypad entry. Unlike the other program quantities, which remain constant until changed, the delay to the first/next sample is continuously being counted down, reflecting the decreasing amount of time remaining until the next sample is collected. Thus, the delay to the first/next sample program quantity is a dynamic quantity, which is counted down from the value entered quantity on the keypad. As mentioned, this allows the user to establish a delay to the first

## MODEL 2900

sample which differs from the interval between the remainder of the samples. It also allows the user to modify the time interval to the next sample by halting the sampler's operation and changing the value of the delay to first/next sample as described in section 2.2.6.3.

DELAY skipped	For a sampler operating in the sequential or composite flow modes (mode 2, 4, or 6), PRGM STEP 3 (DELAY TO FIRST/NEXT SAMPLE) is skipped.
NOMINAL SAMPLE VOLUME	When PRGM STEP 4 (NOMINAL SAMPLE VOLUME) is shown on the display, the nominal sample volume to be placed in the sample bottle may be selected. Sample volume is programmed in terms of 10's of milliliters (ml) of nominal delivered sample volume. The nominal sample volume is selected by entering on the keypad any volume between 1 and 50 -10's of ml for sequential samples and between 1 and 99 10's of ml for composite sampling. For example, a keypad entry of 25 would result in a nominal 250 ml (25 X 10) sample.
Calibrate sample volume	A keypad entry of 0 while PRGM STEP 4 (NOMINAL SAMPLE VOLUME) is shown on the display places the sampler into the calibrate sample volume mode. This mode allows the user to calibrate the delivered sample volume precisely for a given setup. The calibrate sample volume process is described later in this section and in section 2.2.6.1.
Variation from programmed value	It is very important to note that the name of this program quantity refers to the nominal sample volume. The programmed delivery volume should be used only as a nominal indication of the volume of liquid which the sampler will actually deliver into the sample bottle. Depending upon the conditions of use (as discussed below), the actual delivered volume may be different than the programmed volume, although the repeatability of the delivered sample will typically be within the $\pm 10$ ml specification stated in Table 1.4-1. Thus, while the volume of sample delivered into the sample bottles may vary from the programmed setting, the volume of sample will be quite repeatable from bottle to bottle. It is essential to realize that the nominal sample volume is programmable to within 10 ml. This does not imply that the volume of sample actually delivered to the sample bottle will match the programmed volume within 10 ml; as with many digital controls, the nominal sample volume has greater setability than it has accuracy.
Causes of variation	The volume delivered by a peristaltic pump (the type used in the Model 2900 Sampler) is affected by a number of factors: operating suction head, atmospheric pressure, installation and condition of pump tubing, length and inside diameter of the suction line, etc. The volumetric measuring functions programmed into the Model 2900 were determined by careful tests using the correct length of pump tubing and the standard suction lines, at precisely measured operating heads. Any deviation from these conditions will result in a delivered volume which may be different from the programmed volume. For example, improper installation of the pump tubing (too little or too much tubing in the pump housing) will cause a decrease in pumping efficiency and a resultant decrease in delivered volume.
Calibrate sample volume	In sampling procedures where the actual delivered volume is critical (for example, in the multiplex samples per bottle mode), it may be advantageous to select the sample volume using the calibrate sample volume mode. This is described in section 2.2.6.1.
TYPE OF SUCTION LINE	When PRGM STEP 5 (TYPE OF SUCTION LINE) is shown on the display, the type of suction line to be used with the sampler may be selected. The suction line to be used is selected by entering on the keypad the number associated with the suction line. The four suction lines available and the numbers used to select them are as follows:  1 = 1/4" X 10' (1/4 in. ID X 10 ft. long vinyl suction line) (Metric: 6.35 mm X 3 m) 2 = 1/4" X 25' (1/4 in. ID X 25 ft. long vinyl suction line) (Metric: 6.35 mm X 7.6 m) 3 = 3/8" X 10' (3/8 in. ID X 10 ft. long vinyl or Teflon suction lines) (Metric: 9.53 mm X 3 m) 4 = 3/8" X 25' (3/8 in. ID X 25 ft. long vinyl or Teflon suction lines) (Metric: 6.35 mm X 7.6 m)

These suction lines were briefly described in section 2.1.4, above. For example, to set the

## MODEL 2900

sampler up for use with a 1/4" X 10' suction line, the number 1 should be entered on the keypad.

**Nonstandard suction lines** If suction line configurations other than the four listed above are used with the sampler, the calibrate sample volume mode of operation, described later in this section and in section 2.2.6.1, will have to be used to establish the sample volume. When the calibrate sample volume mode is used, it is not necessary to specify the type of suction line, and consequently, PRGM STEP 5 (TYPE OF SUCTION LINE) is skipped when this mode is selected.

**SUCTION HEAD** When PRGM STEP 6 (SUCTION HEAD) is shown on the display, the actual operating suction head of the sampler may be selected. Suction head is the vertical distance the sample must be lifted from the liquid source to the sampler pump. It does not include any horizontal components, but rather is simply the vertical distance from the surface of the liquid source (not the suction line inlet) to the pump inlet. This should not be confused with the suction line length (the physical length of the suction line) which may include some horizontal components.

The actual operating suction head is selected by entering on the keypad any value between 1 and 20 ft. or 4 to 60 decimeters of suction head. If a 10 ft. (3 m) suction line has been programmed, a suction head of greater than 10 ft. or 30 decimeters may not be selected. Suction head can be entered in metric units of measure by placing the sampler into the metric mode of operation.

**Effect of suction head** The Model 2900 Sampler determines the delivered sample volume by counting revolutions of the peristaltic pump rotor. The volume of liquid delivered by one revolution of the pump rotor is a function of the suction head of the pump. As the suction head increases, the volume delivered by one revolution of the pump rotor decreases and vice versa. The programmed suction head value is used to compensate for these changes in delivered volume with operating suction head.

**Determining head** To properly program the suction head, first determine the actual suction head under which the sampler will be operating. Keep in mind that this is the vertical distance from the surface of the liquid source to the sampler pump inlet. Then, enter on the keypad the suction head from 1 to 20 ft. which is closest to the actual suction head. For example, if the actual operating suction head for a particular setup were 8-3/4 ft., a suction head of 9 ft should be entered on the keypad.

**Effect of varying head** In some sampling applications, the operating suction head varies with time because the level of the liquid source is changing due to changing flow rates, the effect of intermittent pumps, etc. In this case, a suction head value should be programmed which is a time weighted average of the suction heads expected to be encountered. It should be recognized, though, that the volume of samples collected during periods of time when the actual suction head does not match the programmed suction head will vary from nominal values.

**SUCTION HEAD skipped** When the calibrate sample volume mode is used, it is not necessary to specify the suction head, and consequently, PRGM STEP 6 (SUCTION HEAD) is skipped when this mode is selected.

**CALIBRATE SAMPLE VOLUME** When PRGM STEP 7 (CALIBRATE SAMPLE VOLUME) is shown on the display, the delivered sample volume may be directly calibrated. This is an alternative to the normal method of sample volume selection (selecting the nominal sample volume, type of suction line, and suction head), and is used to calibrate the delivered sample volume precisely for a given setup. It is useful when very accurate sample volume determination is necessary (for example, when using the samples per bottle multiplex mode) or when nonstandard sampling conditions are encountered (for example, using a nonstandard suction line). The calibrate sample volume mode is selected by entering a zero when PRGM STEP 4 (NOMINAL SAMPLE VOLUME) is shown on the display, as described above.

**Calibration procedure** The calibrate sample volume procedure is fully described in section 2.2.6.1. Briefly, to calibrate the sample volume, the pump tubing is removed from the distributor arm and placed over a graduated cylinder. Then, using the PUMP JOG FWD and PUMP JOG REV keys, a suction line prepurge, line and bottle fill, and suction line postpurge are programmed by

## MODEL 2900

pumping the desired amount of sample volume into the graduated cylinder. The number of volume counts associated with each segment of the sampling cycle will be shown in the display as it is being programmed, along with a "P" (for purge) or "F" (for fill) designator to identify the segment being programmed. Up to five complete fill-purge cycles may be programmed, allowing for suction line preconditioning or other special sampling cycles. The end of the sampling cycle is marked by entering a volume count value of zero on the NUMERIC KEYPAD for either a purge or fill cycle as desired.

**CALIBRATE skipped** PRGM STEP 7 (CALIBRATE SAMPLE VOLUME) will be skipped unless a zero was entered when the PRGM STEP 4 (NOMINAL SAMPLE VOLUME) was shown on the display.

**MULTIPLEX MODE** When PRGM STEP 8 (MULTIPLEX MODE) is shown on the display, the mode of multiplex operation may be selected. The mode to be used is selected by entering on the keypad the number associated with the mode. The modes available and the numbers used to select them are as follows:

- 1 = OFF
- 2 = BOTTLES PER SAMPLE
- 3 = SAMPLES PER BOTTLE

**Use of the two modes** When the bottles per sample mode is selected, up to twenty-four consecutive bottles may be filled in immediate succession. When the samples per bottle mode is selected, up to four consecutive samples may be composited into a common bottle. The bottles per sample mode is useful where a sample volume greater than the capacity of a single bottle is required, or where various types of preservatives must be added to the samples. The samples per bottle mode is useful when it is desirable to collect a series of small composite samples. For example, four samples at 15 minute intervals can be collected in each bottle, resulting in a series of hourly composite samples. When either of the multiplex modes is selected (MODE 2 or 3), the MPLX (multiplex) legend on the display will be on while the sampler is in the program state.

**Bottles per sample mode** In either mode, the sequence of each sample collection cycle remains the same, and only in the addition of immediate consecutive samples or in the action of the distributor does the multiplexer differ from normal sampling. In the bottles per sample mode of operation, when a sampling cycle is initiated (either by internal time or external flow pulse signals), a normal sampling cycle occurs: prepurge, sample collection, postpurge and distributor rotation to the next bottle. Immediately then, however, a second complete sampling cycle is initiated and the next bottle is filled to the preset volume. This immediate filling of consecutive adjacent sample bottles by a complete sampling cycle continues up to the number of bottles (a maximum of 24) programmed. The sampler then pauses until the next sample initiation signal occurs, at which time the sampling into multiple adjacent bottles will repeat.

**Samples per bottle mode** In the samples per bottle mode of operation when a sampling cycle is initiated, a normal sampling cycle again occurs with the exception that the distributor does not index to the next bottle position at the end of the cycle. The sampler pauses until the next sampling cycle is initiated, at which time a second sample is collected and deposited into the sample bottle. This compositing of multiple samples continues up to the number of samples (a maximum of 4) programmed. After the last sample is deposited in the bottle, the distributor immediately rotates to the next bottle position and the collection of multiple samples into the same bottle will repeat at the time or flow interval programmed.

**MULTIPLEX mode skipped** PRGM STEP 8 (MULTIPLEX MODE) will be skipped if modes 5 or 6 (composite time or composite flow) were entered in PRGM STEP 1 (MODE).



## MODEL 2900

MULTIPLEX NUMBER	When PRGM STEP 9 (MULTIPLEX NUMBER) is shown on the display, the number of consecutive bottles to be filled or the number of samples to be composited into a single bottle may be selected. The quantity to be selected is determined by the multiplex mode previously programmed.
Bottles per sample mode	<p>When the bottles per sample multiplex mode has been programmed, the number of consecutive adjacent bottles to be filled at each sampling cycle initiation is selected when PRGM STEP 9 (MULTIPLEX NUMBER) is shown on the display. The entries the sampler will accept varies according to the mode selected in PRGM STEP 1 (MODE). For example, the sampler will accept multiplex numbers of 2 to 24 for samplers previously programmed for 24 bottle sequential sampling in PRGM STEP 1 (MODE). Samplers previously programmed for 12 bottle sequential sampling will accept multiplex numbers of 2 to 12. The acceptable entries are noted on the control panel label under the bottles per sample heading of step 9. The control panel label is shown in Figure 2.2-1.</p> <p>When programming the sampler in the 24 bottle sequential mode, selecting 2, 3, 4, 6, 8, 12, or 24 bottles per sample will result in twelve sets of two identical samples, eight sets of three identical samples, six sets of four identical samples, four sets of six identical samples, three sets of eight identical samples, two sets of twelve identical samples or one set of twenty-four immediately consecutive samples, respectively. If any other number of bottles per sample is selected, the last set of samples will contain a smaller number of samples than the number programmed. For example, programming 5 bottles per sample will result in four sets of five identical samples and one last set of four identical samples.</p> <p>A comparable multiplexing scheme is used for sampler programmed in the 12 bottle sequential mode. Selecting 2, 3, 4, 6, or 12 bottles per sample will result in six sets of two identical samples, four sets of three identical samples, three sets of four identical samples, two sets of six identical samples, or one set of twelve immediately consecutive samples, respectively. If any other number of bottles per sample is selected, the last set of samples will contain a smaller number of samples.</p>
Number of bottles calculation	If the bottles per sample multiplex mode is being used to collect a volume larger than the capacity of a single bottle (500 ml), divide the desired total volume by 500 ml and round the answer to the next higher number (to a maximum of 24 for the 24 bottle tub or 12 for the 12 bottle tub). The resulting number is the number of bottles selection which will result in the desired total volume being collected in a series of consecutive bottles. (Note that a sample volume of 500 ml should be programmed.)
Use with preservatives	If the multiplex bottles per sample mode is being used to add preservatives to a number of consecutive samples, select a number of bottles value equal to the number of different bottles to be used in one sequence (to a maximum of 24 or 12, depending on the mode selected in PRGM STEP 1 (MODE)). Then add the preservatives to the bottles in a repeating sequence. When selecting the volume per sample, be sure to take the volume of the preservative into account, to prevent a possible bottle overflow.
Samples per bottle mode	When the samples per bottle multiplex mode has been programmed, the number of samples to be composited into a single bottle is selected when PRGM STEP 9 (MULTIPLEX NUMBER) is shown on the display. When using this mode, be sure that the total volume of the samples to be composited does not exceed the capacity of a single bottle. This will allow two 250 ml samples, three 160 ml samples, or four 120 ml samples to be placed in the 500 ml bottle used by the 24 bottle tub. Alternatively, it will allow two 180 ml samples, three 125 ml samples, or four 90 ml samples to be placed in the 375 ml bottle used by the 12 bottle tub.
Sample volume considerations	When selecting the sample size in the samples per bottle multiplex mode, the $\pm 10$ ml sample volume repeatability should be kept in mind (refer to Table 1.4-1 and sections 2.2). Because the sample volume programmed is only a "nominal" value, it is probably prudent to select a total sample volume which is somewhat less than the volumetric capacity of the bottle, as a safety factor. Consideration should also be given to programming the sample volume using the calibrate sample volume mode, as described below and in section 2.2.6.1; this will generally result in more accuracy in the volume selection process.

## MODEL 2900

**MULTIPLEX NUMBER skipped** PRGM STEP 9 (MULTIPLEX NUMBER) is skipped when nonmultiplex operation has been selected.

**NUMBER OF SAMPLES** When PRGM STEP 10 (NUMBERS of SAMPLES) is shown on the display, the number of individual composite samples to be collected before the sampling process is terminated may be selected. The number of composite samples is selected by entering on the keypad any value between 1 and 999 samples. For example programming a value of 50 for the number of composite samples will cause the sampler to place 50 individual samples into the composite container, and then shut off. When using this mode, be sure that the total volume of the samples to be composited does not exceed the capacity of the one gallon (3785 ml) composite bottle.

**2.2.3.3 Humidity Indicator** - A humidity indicator, labeled INTERNAL CASE HUMIDITY, is located in the lower right hand corner of the control panel. The humidity indicator, visible through a window in the panel, indicates the amount of moisture which is present inside the control box. The paper indicator is all blue in a dry state. If moisture begins to accumulate in the control box, the numbered areas on the indicator will turn light pink or white, starting with the area numbered "20." This indicates that the relative humidity inside the control box exceeds 20%. As more moisture accumulates in the control box, the areas numbered "30" and "40" will turn light pink or white, indicating relative humidities of 30% and 40%.

**Use of the indicator** The control box is a completely sealed unit, which does not need to be opened during normal operation. It is shipped from the factory with a fresh 4 oz. bag of desiccant installed inside the control box. This desiccant should absorb any moisture which might leak into the control box. Thus, the humidity indicator should remain blue under normal conditions. If the 30% area of the humidity indicator turns light pink or white, the control unit should be opened, inspected to determine if there is a leak, and the desiccant renewed, as described in section 3.5.

**2.2.4 General Programming Considerations** - An overview of the sampler programming process was presented in section 2.2.2, above. The sections following this section will present detailed procedures on standard and advanced sampler programming. This section will introduce some general programming considerations and procedures that are common to all the sampler programming modes.

**Learning to program** The most effective way to learn how to program the Model 2900 Sampler is to read this and the following sections, get a sampler, and experiment. The sampler cannot be harmed by improper programming, so there is nothing to be lost by experimenting. The Model 2900 is basically a simple, straightforward, "user-friendly" unit. However, as with most programmable devices, there are certain rules and quirks that must be learned. A few minutes in the office or laboratory spent in actually programming the sampler and observing its operation usually proves to be a worthwhile investment of time. Simply "playing" with the sampler is the best way to become familiar with programming, and may help avoid costly delays or problems when the sampler is used in the field.

**Basic programming sequence** The basic programming sequence comprises seven steps and is listed on the Model 2900 control panel:

1. Press ON key.
2. Press PROGRAM/STEP key.
3. Enter, on the NUMBER KEYS, the desired setting for program step indicated on the display.
4. Press ENTER VALUE key.
5. Press PROGRAM/STEP key.
6. Repeat steps 3, 4, and 5 for all program steps.

## MODEL 2900

### 7. Press START SAMPLING key to start sampling program.

- Programming process** Pressing the ON key turns the sampler on and places it in the standby state. Pressing the PROGRAM/STEP key transfers the sampler into the program state (allowing it to be programmed). PRGM STEP 1 (MODE) will be shown in the display, indicating that the mode of sampler operation is to be programmed. Note that the display alternates between PRGM STEP 1 and the mode previously programmed. One of the two modes may then be selected by pressing a key on the NUMERIC KEYPAD corresponding to the desired mode. As soon as a number is entered on the keypad, the alternating nature of the display is stopped, and only the newly entered mode is shown on the display. The mode selected is then entered into the sampler's memory by pressing the ENTER VALUE key. After the ENTER VALUE key has been pressed, the alternation of the display between PRGM STEP 1 and the newly entered mode is restored. Pressing the PROGRAM/STEP key steps the unit to PRGM STEP 2 (INTERVAL BETWEEN SAMPLES). The interval between samples is then programmed in a similar manner, and the next program quantity is sequenced to. This process is repeated until all the program quantities have been programmed, at which time pressing the PROGRAM/STEP key will return the sampler to the standby state. If the sampler is left in the program state, and there is no activity on the keyboard for approximately five minutes, it will be automatically transferred to the standby state. Pressing the START SAMPLING key places the sampler into the run state, resets the distributor to the bottle number 1 position (if it is not already there), and starts the sampling program.
- PROGRAM/STEP key** As mentioned in section 2.2.3.1.3, the PROGRAM/STEP key contains an implied enter value function. Thus, if the user desires, the PROGRAM/STEP key may be used alone both to enter into the sampler's memory the quantity being programmed and to simultaneously sequence to the next program quantity. This is one less keystroke than is used in the basic programming sequence listed above (press ENTER VALUE key, then press PROGRAM/STEP key). Functionally, the ENTER VALUE key is redundant, since its function is contained within the PROGRAM/STEP key. However, the ENTER VALUE key is provided because its use is thought to be more intuitively obvious to the beginning user. The programming procedures in the following sections utilize the two step method (ENTER VALUE and PROGRAM/STEP) of entering a program quantity into memory and sequencing to the next program quantity. However, the reader should recognize that this two step procedure can (and probably will by the experienced programmer) be replaced by a single depression of the PROGRAM/STEP key.
- CLEAR ENTRY key** Also as mentioned in section 2.2.3.1.3, the CLEAR ENTRY key has additional uses beyond clearing a previously entered program quantity. Pressing the CLEAR ENTRY key will cause a newly entered program quantity shown on the display to be replaced with the previously entered program quantity. This allows keyboard entry errors to be corrected before the program quantity is loaded into the sampler's memory. A second depression of the CLEAR ENTRY key (without an intermediate depression of one of the numeric keys) will cause the sampler to be transferred from the program to the standby state. Likewise, if no new value has been entered before the CLEAR ENTRY key is pressed, the sampler will also be transferred from the program to the standby state. This is to provide the user with a means of getting out of the programming state without sequencing through all the program quantities. This is useful when it is necessary to change only one of the program quantities. The quantity to be changed may be sequenced to using the PROGRAM/STEP key, the new quantity entered, and the sampler transferred from the program to the standby state by pressing the CLEAR ENTRY key.
- Keypad feedback** As discussed in section 2.2.3.1, the sampler's keypad features both tactile and audio feedback to assure that the key switch has been successfully actuated during the programming process. When one of the keys is pressed, the user will both feel the switch as it is actuated and hear a "beep" generated by an audio indicator inside the sampler.
- Invalid keypad entry** An audio indication is also provided should the user attempt to key in a value which is invalid for the program quantity being set. In the case of an invalid entry, the sampler will "beep" rapidly for a few moments, and then replace on the display the improper entry with the previously entered value. For example, when PRGM STEP 1 (MODE) is shown on the display, only the numbers 1, 2, 3, 4, 5, and 6 are valid entries. As soon as an invalid entry is

## MODEL 2900

keyed in on the numeric keypad, say a 7, the sampler will "beep" rapidly for a few moments, and then replace the 7 on the display with the previously entered value, say a 1.

### Keys functional only in certain states

As discussed in section 2.2.2, the sampler has five basic states of operation. Depending on which state the sampler is in, only certain keys on the keypad will be functional. In the off state, only the ON key is functional. In the standby state, all keys are functional except the numeric keys 0 through 9. In the program state, the numeric keys 0 through 9 and the first three program control keys (PROGRAM/STEP, ENTER VALUE, and CLEAR ENTRY) are functional. When the calibrate sample volume mode is being used, the PUMP JOG FWD and PUMP JOG REV keys are also functional in the program state, but only when PRGM STEP 7 (CALIBRATE SAMPLE VOLUME) is shown on the display. In the run state, only the PUMP STOP, PROGRAM/STEP, and HALT SAMPLING keys are functional. In the full state, the first four program control keys (PROGRAM/STEP, ENTER VALUE, CLEAR ENTRY, and START SAMPLING) are functional. Of course, in all states except off, the OFF key is also functional.

### Program scan

After the sampler has been programmed and placed into operation (sampler in the run state), the programmed values of the various program quantities may be reviewed at any time by pressing the PROGRAM/STEP key. This places the sampler into a program scan mode, whereby all the program quantities may be stepped through by repeatedly pressing the PROGRAM/STEP key, showing on the display the program quantity step number followed by the value of the program quantity. While the program is being scanned in this manner the PRGM legend will be shown on the display in addition to the RUN legend. If, after a program scan has been initiated, the PROGRAM/STEP key is not pressed again, the scan mode will be terminated after approximately 60 seconds. After the last applicable program quantity has been stepped through, the sampler will return to the normal run state. If a sample initiation occurs during a program scan, the sample will be delayed until after the scan has ended.

### Continuous memory

As mentioned in section 2.1.7, the Model 2900 Sampler has a small internal lithium battery which maintains the sampler's program when external power is interrupted or the unit is turned off. Thus, the sampler has what is conventionally referred to as "continuous memory." When the sampler is shipped from the factory, the unit will be programmed with a standard test program. The user should be aware that, because of the continuous memory, there will always be a program in existence in the sampler.

As a final note to the general programming considerations, the timing and flow pulse counting logic of the sampler will be discussed. The timing logic of the sampler was established to allow the user to easily synchronize sample collections with real time. This is accomplished by continuously decrementing (counting down) the time interval to the next sample in all sampler states except off. In this way, synchronization with real clock time may be easily and directly established by setting of delay to the first/next sample. For example, if the time of day is 9:37 and it is desired to collect the first sample at 10:00, programming a delay to first/next sample of 23 minutes would accomplish this, since the delay to the first sample is decremented from the moment the delay is programmed. Also, synchronization is not lost when the program is interrupted by the use of the HALT key or when the program is completed. Time decrementing is stopped only when the sampler is turned off. The flow pulse interval to the next sample, on the other hand, is decremented only when the sampler is in the run state.

## MODEL 2900

### Delay to first sample

Consistent with this is the manner in which the time or flow pulse delay to the first sample is handled upon program start (the depression of the START SAMPLING key) for the two basic modes of sampler operation:

Modes 1, 3, 5 (all time paced modes) - The delay is not affected by program start.

Modes 2, 4, 6 (all flow paced modes) - Upon program start, the flow pulse interval to the first sample will be reset to the programmed flow pulse interval between samples.

**2.2.5 Standard Programming** - The following two sections describe in detail the methods of programming the Model 2900 Sampler for automatic sample collection in the sequential time and flow modes. The procedures in the following sections define the "standard" programming techniques for the sampler. For the more advanced programming techniques, refer to section 2.2.6, below.

To fully understand the programming methods discussed in the following sections, the reader should be thoroughly familiar with the introductory material on programming and the sampler's controls, presented in sections 2.2.1 through 2.2.4. Each of the following sections will present a specific set of step-by-step instructions for programming the sampler in one of the six standard modes. With the exception of the composite programming examples, all instructions assume the 24 bottle tub is being used.

**2.2.5.1 Sequential Time** - The object of sequential time sampling using the Model 2900 is to collect a sequential series of discrete equal volume samples at a known regular time interval and to place these samples in an identifiable series of sample bottles. To program the sampler for automatic operation in a sequential time mode, the use of the following set of step-by-step instructions is recommended. These instructions assume that the sampler is off and that the sample bottle tub has been properly prepared with 24 sample bottles, as described in section 2.1.2.

STEP NO.	PROGRAM QUANTITY TO BE SET	DISPLAY
1. Press ON key. Places the sampler into the standby state.	1. None	1. STANDBY legend on. This alternates between bottle number (" 3"* - BTL# legend), time or flow pulse interval to next sample ("0014"* - TIME or FLOW legend), and the multiplex step number (" 2"* - MPLX STEP legend), if applicable. If sampling previously completed, bottle number replaced with text "FULL." If the multiplex mode is programmed, the MPLX legend is on.
2. Press PROGRAM/STEP key. This places the sampler into the program state.	2. MODE	2. Alternates between PRGM STEP 1 and previously programmed mode (" 2"*). PRGM legend is on as long as sampler remains in program state. FLOW* legend on.
3. Enter mode 1 (TIME) on the numeric keypad.	3. MODE	3. " 1"
4. Press ENTER VALUE key.	4. MODE	4. Alternates between PRGM STEP 1 and newly entered mode (" 1"). TIME legend is on as long as sampler remains in program state.
5. Press PROGRAM/STEP key.	5. INTERVAL BETWEEN SAMPLES	5. Alternates between PRGM STEP 2 and previously programmed interval in minutes (" 15"*).

## MODEL 2900

STEP NO.	PROGRAM QUANTITY TO BE SET	DISPLAY
6. Enter on the numeric keypad the desired interval between samples in minutes (up to 9999 minutes). For example, assume it is desired to collect samples at 60 minute intervals -- enter 60 on the numeric keypad.	6. INTERVAL BETWEEN SAMPLES	6. " 60"
7. Press ENTER VALUE key.	7. INTERVAL BETWEEN SAMPLES	7. Alternates between PRGM STEP 2 and newly entered interval in minutes " 60").
8. Press PROGRAM/STEP key.	8. DELAY TO FIRST/NEXT SAMPLE	8. Alternates between PRGM STEP 3 and present interval to the next sample in minutes (" 11"*).
9. Enter on the numeric keypad the desired delay until the first sample is collected in minutes (up to 9999 minutes).	9. DELAY TO FIRST/NEXT SAMPLE	9. " 45"
<p>Note that this is the time interval from the present time until the time when it is desired to collect the first sample. For example, assume that it is presently 7:15 a.m., and it is desired to collect the first sample at 8:00 a.m. -- enter 45 on the numeric keypad.</p>		
10. Press ENTER VALUE key.	10. DELAY TO FIRST/NEXT SAMPLE	10. Alternates between PRGM STEP 3 and present interval to the next sample in minutes (" 45").
11. Press PROGRAM/STEP key.	11. NOMINAL SAMPLE VOLUME	11. Alternates between PRGM STEP 4 and previously programmed nominal sample volume in 10's of ml (" 45"*).
12. Enter on the numeric keypad the desired sample volume in 10's of milliliters (to a maximum of 50). For example, assume that it is desired to collect samples with a volume of 250 ml -- enter 25 on the numeric keypad.	12. NOMINAL SAMPLE VOLUME	12. " 25"
13. Press ENTER VALUE key.	13. NOMINAL SAMPLE VOLUME	13. ALTERNATES BETWEEN PROGRAM STEP 4 and newly entered sample volume in 10's of ml (" 25").
STEP NO.	PROGRAM QUANTITY TO BE SET	DISPLAY
14. Press PROGRAM/STEP key.	14. TYPE OF SUCTION LINE	14. Alternates between PRGM STEP 5 and previously programmed type of suction line (" 3"*).

## MODEL 2900

STEP NO.	PROGRAM QUANTITY TO BE SET	DISPLAY
15. Enter on the numeric keypad the number corresponding to the desired type of suction line. For example, assume that a 1/4" ID X 10' long suction line is being used -- enter type 1 (1/4" X 10') on the numeric keypad.	15. TYPE OF SUCTION LINE	15. " 1"
16. Press ENTER VALUE key.	16. TYPE OF SUCTION LINE	16. Alternates between PRGM STEP 5 and newly entered type of suction line (" 1").
17. Press PROGRAM/STEP key.	17. SUCTION HEAD	17. Alternates between PRGM STEP 6 and previously programmed suction head in feet (" 10"*).
18. Enter on the numeric keypad the suction head in feet, to a maximum of 20 ft. The suction head is the vertical distance from the surface of the liquid source to the pump inlet. For example, assume that the suction head in 6 ft. -- enter 6 on the numeric keypad.	18. SUCTION HEAD	18. " 6"
19. Press ENTER VALUE key.	19. SUCTION HEAD	19. Alternates between PRGM STEP 6 and newly entered suction head in feet (" 6").
20. Press PROGRAM STEP PROGRAM key.	20. MULTIPLEX MODE	20. Alternates between PRGM STEP 7 and previously programmed multiplex mode (" 2"*). For mode 2, MPLX legend on.
21. Enter on the numeric keypad the number corresponding to the desired mode of multiplex operation on the numeric keypad. For example, assume that no multiplex operation is desired -- enter mode 1 on the numeric keypad.	21. MULTIPLEX MODE	21. " 1"
(NOTE: Instruction and examples of multiplex programming will be presented late in this section.)		
22. Press ENTER VALUE key.	22. MULTIPLEX MODE	22. Alternates between PRGM STEP 7 and newly entered multiplex mode (" 1"). MPLX legend off.
23. Press PROGRAM/STEP key. This returns the sampler to the standby state.	23. None	23. STNDBY legend on. Alternates between bottle number (" 3" - BTL# legend and the time interval to next sample ("0014"); if sampling previously completed, bottle number replaced with text "FILLI."

## MODEL 2900

STEP NO.	PROGRAM QUANTITY TO BE SET	DISPLAY
24. Press the <b>START SAMPLING</b> key. This places the sampler in the run state. If the display previously had shown a bottle number other than 1 or "FULL," the distributor will automatically be repositioned to the bottle number 1 position.	24. None	24. RUN legend on. Alternates between bottle number (" 1" - BTL# legend) and time interval in minutes until the first/next sample is collected ("0042" - TIME legend).

### Operation in time mode

This completes the programming of Model 2900 Sampler in a non-multiplex sequential time mode. Following the example, after the initial delay of 45 minutes from the moment the 45 minute delay was entered in step 9, a sample of 250 ml will be placed in the first sample bottle at 8:00 a.m. The display will continue to alternate between the time in minutes remaining until the next sample is collected (for example, "0031" - TIME legend) and the bottle number into which the sample will be placed (for example, " 2 " - BTL# legend). After the first sample has been collected, the time interval to the next sample will be reset to the programmed value of 60 and will start decrementing. When it decrements to zero, a sample will be collected, the display will be reset to the programmed value of 60 and the decrementing process will be started again. The 250 ml samples will continue to be collected at 60 minute intervals on the hour until the 24th and last sample bottle has been filled, at which time the sampler will shut off, and the display will read "FULL."

### Multiplex bottles per sample example

The above instructions and accompanying example are concerned with non-multiplex time sampling. To program the sampler for time sampling with multiplex bottles per sample, follow steps 1 through 20, above. Then, follow these procedures:

STEP NO.	PROGRAM QUANTITY TO BE SET	DISPLAY
21. Enter on the numeric keypad mode 2 (BOTTLES PER SAMPLE).	21. MULTIPLEX MODE	21. " 2"
22. Press <b>ENTER VALUE</b> key.	22. MULTIPLEX MODE	22. Alternates between PRGM STEP 7 and newly entered multiplex mode (" 2"). MPLX legend remains on.
23. Press <b>PROGRAM/STEP</b> key.	23. MULTIPLEX NUMBER	23. Alternates between PRGM STEP 8 and previously programmed number of bottles per sample (" 2"*).
24. Enter on the numeric keypad of the desired number of multiplex bottles per sample (to a maximum of 24). For example, assume that it is desired to collect 3 identical samples in separate bottles at each sample initiation -- enter 3 on the numeric keypad.	24. MULTIPLEX NUMBER	24. " 3"
25. Press <b>ENTER VALUE</b> key.	25. MULTIPLEX NUMBER	25. Alternates between PRGM STEP 8 and newly entered number of bottles per sample (" 3").



## MODEL 2900

STEP NO.	PROGRAM QUANTITY TO BE SET	DISPLAY
26. Press PROGRAM/STEP key. This returns the sampler to the standby state.	26. None	26. STANDBY and MPLX legends on. Alternates between bottle number (" 3" - BTL# legend) and time interval to next sample ("0014" - TIME legend); if sampling previously complete, bottle number replaced with text "FULL."
27. Press the START SAMPLING key. This places the sampler in the run state. If the display previously had shown a bottle number other than 1 or "FULL," the distributor will automatically be repositioned to the bottle number 1 position.	27. None	27. RUN and MPLX legends on. Alternates between bottle number (" 01" - BTL# legend) and time interval to first/next sample ("0042" - TIME legend).

\* EXAMPLE - may be other value

Operation in multiplex bottles per sample mode

This completes the programming of the Model 2900 Sampler in a multiplex bottles per sample time mode. Following the example, after the initial delay of 45 minutes from the moment the 45 minutes delay was entered in step 9, samples of 250 ml will be immediately placed in each of the first three sample bottles, at 8:00 a.m. The action of the display will be as described above; only the number of the first bottle in the sequence of three bottles to be filled will ever be shown (bottle number 1, 4, 7, 11, etc.). The MPLX legend of the display always remains on to indicate that the sampler is in a multiplex mode. Sixty minutes after the first sampling cycle, the next three bottles will be filled with 250 ml each. This process will continue at an interval of 60 minutes until the last of eight sets of three bottles each has been filled, at which time the sampler will shut off and the display will read "FULL." The result is eight sets of three sample bottles containing essentially identical 250 ml samples each.

Multiplex samples per bottle example

To program the sampler for time sampling with multiplex samples per bottle, follow steps 1 through 20 above. Then, follow these procedures:

STEP NO.	PROGRAM QUANTITY TO BE SET	DISPLAY
21. Enter on the numeric keypad mode 3 (SAMPLES PER BOTTLE).	21. MULTIPLEX MODE	21. " 3"
22. Press ENTER VALUE key.	22. MULTIPLEX MODE	22. Alternates between PRGM STEP 7 and newly entered multiplex mode (" 3"). MPLX legend remains on.
23. Press PROGRAM/STEP key.	23. MULTIPLEX NUMBER	23. Alternates between PRGM STEP 8 and previously programmed number of samples per bottle (" 4").
24. Enter on the numeric keypad the desired number of multiplex samples per bottle (to a maximum of 10). For example, assume that it is desired to composite 2 equal size samples into each individual sample bottle -- enter 2 on the numeric keypad.	24. MULTIPLEX NUMBER	24. " 2"

## MODEL 2900

STEP NO.	PROGRAM QUANTITY TO BE SET	DISPLAY
25. Press ENTER VALUE key.	25. MULTIPLEX NUMBER	25. Alternates between PRGM STEP 8 and newly entered number of samples per bottle (" 2").
STEP NO.	PROGRAM QUANTITY TO BE SET	DISPLAY
26. Press PROGRAM/STEP key. This returns the sampler to the standby state.	26. None	26. STNDBY and MPLX legends on. Alternates among bottle number (" 3" - BTL# legend), time interval to next sample ("0014" - TIME legend), and the multiplex step number (" 2" - MPLX STEP legend); if sampling previously completed, bottle number replaced with text "FULL."
27. Press the START SAMPLING key. This places the sampler in the run state. If the display previously had shown a bottle number other than 1 or "FULL," the distributor will automatically be repositioned to the number 1 position.	27. None	27. RUN and MPLX legend on. Alternates among bottle number (" 1" - BTL# legend), time interval to first/next sample ("0042" - TIME legend), and the multiplex step number (" 1" - MPLX STEP legend).

\* EXAMPLE - may be other value

### Operation in multiplex samples per bottle mode

This completes the programming of the Model 2900 Sampler in a multiplex samples per bottle time mode. Following the example, after the initial delay of 45 minutes from the moment the 45 minute delay was entered in step 9, a 250 ml sample will be placed in the first sample bottle at 8:00 a.m. After the sample has been collected, the distributor will not move, but rather remains over the first sample bottle. A second 250 ml sample will then be placed in the first sample bottle at a 60 minute interval. After the second sample has been placed in the first sample bottle, the distributor will index to the second sample bottle and the process of compositing two samples at 60 minute intervals into each of the sample bottles will continue. The action of the display will be as described above, except that a third alternating quantity will be added, the multiplex step number of the next sample (for example, " 3 " - MPLX STEP legend). The display thus indicates both the bottle number and multiplex step number of the next sample to be collected. The MPLX legend of the display always remains on to indicate that the sampler is in a multiplex mode. The sampling process continues until the final sample is composited into the 24th and last sample bottle, at which time the sampler will shut off, and the display will read "FULL." The result is 24-500 ml samples, each composed of two individual 250 ml composite samples collected at 60 minute intervals.

**2.2.5.2 Sequential Flow** - The object of sequential flow sampling using the Model 2900 is to collect a sequential series of discrete equal volume samples at a known regular flow interval and to place these samples in an identifiable series of sample bottles. As discussed in section 2.1.8, the Model 2900 will accept flow proportional inputs of a certain specific nature from an external flow meter. These electronic flow input signals are transmitted to the sampler at fixed increments of total flow, for example every 10,000 gallons. That is, each time 10,000 gallons of liquid has flowed past the flow meter, a signal is sent to the sampler, which registers it as a single flow pulse. The Model 2900 Sampler can be programmed to totalize any number of flow pulses from 1 to 9999 before a sampling cycle is initiated. For example, if the sampler were programmed to totalize 5 flow pulses and each flow pulse represented 10,000 gallons of total flow, a sample would be collected each time 50,000 gallons (5 flow pulses of 10,000 gallons each) had flowed past the flow meter.

### Flow example

To program the sampler for automatic operation in a flow mode the use of the following set of step-by-step instructions is recommended. These instructions assume that the sampler is off and that the sample bottle tub has been properly prepared with 24 sample bottles, as described in section 2.1.2.

## MODEL 2900

STEP NO.	PROGRAM QUANTITY TO BE SET	DISPLAY
1. Press ON key. This places the sampler into the standby state.	1. None	1. STNDBY legend on. Alternates between bottle number (" 3" - BTL# legend), time or flow pulse interval to next sample ("0014"* - TIME or FLOW legend), and the multiplex step number (" 2" - MPLX STEP legend), if applicable. If sampling previously completed, bottle number replaced with text "FULL." If multiplex mode programmed, MPLX legend on.
2. Press PROGRAM/STEP key. This places the sampler into the program state.	2. MODE	2. Alternates between PRGM STEP 1 and previously programmed mode (" 1"*). PRGM legend is on as long as sampler remains in program state. TIME* legend on.
3. Enter on the numeric keypad Mode 2 (FLOW).	3. MODE	3. " 2"
4. Press ENTER VALUE key.	4. MODE	4. Alternates between PRGM STEP 1 and newly entered mode (" 2"). FLOW legend is on as long a sampler remains in program state.
5. Press PROGRAM/STEP key.	5. INTERVAL BETWEEN SAMPLES	5. Alternates between PRGM STEP 2 and previously programmed interval in flow pulses (" 15"*).
6. Enter on the numeric keypad the desired interval between samples in flow pulses (up to 9999 flow pulses. For example, assume it is desired to collect samples at 100,000 gallon intervals, and each flow pulse represents 20,000 gallons -- enter 5 (100,000/20,000 = 5) on the numeric keypad.	6. INTERVAL BETWEEN SAMPLES	6. " 5"
7. Press ENTER VALUE key.	7. INTERVAL BETWEEN SAMPLES	7. Alternates between PRGM STEP 2 and newly entered interval in flow pulses (" 5").
8. Press PROGRAM/STEP key.	8. NOMINAL SAMPLE VOLUME	8. Alternates between PRGM STEP 4 and previously programmed nominal sample volume in 10's of ml (" 25"*).
9. Enter on the numeric keypad the desired nominal sample volume in 10's of milliliters (to a maximum of 50). For example, assume that it is desired to collect samples with a volume of 450 ml -- enter 45 on the numeric keypad.	9. NOMINAL SAMPLE VOLUME	9. " 45"
10. Press ENTER VALUE key.	10. NOMINAL SAMPLE VOLUME	10. Alternates between PRGM STEP 4 and newly entered sample volume in 10's of ml (" 45").
11. Press PROGRAM/STEP key.	11. TYPE OF SUCTION LINE	11. Alternates between PRGM STEP 5 and previously programmed type of suction line (" 3"*).

## MODEL 2900

STEP NO.	PROGRAM QUANTITY TO BE SET	DISPLAY
12. Enter on the numeric keypad the number corresponding to the desired type of suction line. For example, assume that a 1/4" ID by 25' long suction line is being used -- enter type 2 (1/4" X 25') on the numeric keypad.	12. TYPE OF SUCTION LINE	12. " 2"
13. Press ENTER VALUE key.	13. TYPE OF SUCTION LINE	13. Alternates between PRGM STEP 5 and newly entered type of suction line (" 2").
14. Press PROGRAM/STEP key.	14. SUCTION HEAD	14. Alternates between PRGM STEP 6 and previously programmed suction head in feet (" 10"*).
15. Enter on the numeric keypad the suction head in feet, to a maximum of 20 feet. The suction head is the vertical distance from the surface of the liquid source to the pump inlet. For example, assume that the suction head is 12 feet -- enter 12 on the numeric keypad.	15. SUCTION HEAD	15. " 12"
16. Press ENTER VALUE key.	16. SUCTION HEAD	16. Alternates between PRGM STEP 6 and newly entered suction head in feet (" 12").
17. Press PROGRAM/STEP key.	17. MULTIPLEX MODE	17. Alternates between PRGM STEP 7 and previously programmed multiplex mode (" 2"*). For mode 2, MPLX legend on.
18. Enter the number corresponding to the desired mode of multiplex operation on the numeric keypad. For example, assume that no multiplex operation is desired -- enter mode 1 on the numeric keypad.	18. MULTIPLEX MODE	18 " 1"
NOTE: Instructions and examples of multiplex programming were presented in section 2.2.5.1.		
19. Press ENTER VALUE key.	19. MULTIPLEX MODE	19. Alternates between PRGM STEP 7 and newly entered multiplex mode (" 1"). MPLX legend off.
20. Press PROGRAM/STEP key. This returns the sampler to the standby state.	20. None	20. STNDBY legend on. Alternates between bottle number (" 3" - BTL# legend) and flow pulse interval to next sample ("0003" - FLOW legend); if sampling previously completed, bottle number replaced with text "FULL."

## MODEL 2900

STEP NO.	PROGRAM QUANTITY TO BE SET	DISPLAY
21. Press the START SAMPLING key. This places the sampler in the run state. If the display previously had shown a bottle number other than 1 or "FULL," the distributor will automatically be repositioned to the bottle number 1 position.	21. None	21. RUN legend on. Alternates between bottle number (" 1"), BTL# legend) and interval in flow pulses until the first/next sample is collected ("0003" - FLOW legend).

\* EXAMPLE - may be other value

**Operation in flow mode** This completes the programming of the Model 2900 Sampler in a flow mode. Following the example, the sampler will collect the first 450 ml sample in the first sample bottle after 5 flow pulses (100,000 gallons) have been received from the external flow meter. The display will continue to alternate between the interval in flow pulses remaining until the next sample is collected (for example, "0004" - FLOW legend) and the bottle number into which the sample will be placed (for example, " 2 " - BTL# legend). The flow pulse interval to the next sample is reset to the programmed value of 5 when the START SAMPLING key is pressed in step 21. As flow pulses are received from the external flow meter, the flow pulse interval to the next sample shown in the display will decrement to zero, at which point a sample will be collected, the display will be reset to the programmed value of 5 and the decrementing process will begin again as flow pulses are received. The 450 ml samples will continue to be collected at 5 flow pulse (100,000 gallon) intervals until the 24th and last sample bottle has been filled, at which time the sampler will shut off, and the display will read "FULL."

**2.2.5.3 Composite Time** - The object of composite time sampling using the Model 2900 is to collect a series of discrete, equal volume samples at a known regular time interval, and to place these samples into a single composite sample container. When programming the sampler in a composite time mode, two quantities must be calculated to allow the sampler to be programmed in a rational manner: the total number of samples to be collected and the volume of each individual sample.

**Calculation of total number of samples** To calculate the total number of samples to be collected, two quantities must be known: the time increment between samples and the total time over which the composite sample is to be collected. The total number of samples to be collected is calculated by dividing the total time over which the composite sample is to be collected by the time increment between samples. For example, assume that the duration of the composite sampling is to be 24 hours and that it is desired to collect samples at 15 minute intervals. The total number of samples to be collected is calculated:

$$12 \text{ hours} \times 60 \text{ minutes/hour} = 120 \text{ minutes}$$

$$720 \text{ minutes} \div 15 \text{ minutes/sample} = 48 \text{ samples}$$

Thus 48 individual samples will be collected over the 12 hour period.

**Calculation of sample volume** To calculate the volume of each individual sample, the size of the composite container being used and the total number of samples to be collected (calculated above) must be known. Isco provides a 1 gallon (3,785 ml) container for use with the Model 2900.

The individual sample volume is calculated by simply dividing the volume of the composite sample container by the total number of samples to be collected. For example, assume that a total of 96 samples are to be collected in the one gallon container. The individual sample volume is then calculated:

$$3785 \text{ ml} \div 48 \text{ samples} = 78.85 \text{ ml/sample}$$

## MODEL 2900

Thus, a sample volume of 70 ml (the next smaller volume which may be programmed on the Model 2900) will result in the desired composite sample. It is important to select an individual sample volume which will not result in an overfilled sample container under worst-case conditions. Because of the basic uncertainty of the delivered sample volume exactly matching the programmed nominal sample volume and the  $\pm 10$  ml sample repeatability, it is good practice to select a sample volume which is slightly smaller than the calculated sample volume. This is to prevent over filling of the sample container. For critical applications, it may be useful to use the calibrate sample volume mode, as described in section 2.2.6.1.

### Calculation of total sample volume

The nominal total volume of the composite sample may be calculated by multiplying the programmed nominal sample volume by the total number of samples to be collected. In the example:

$$70 \text{ ml} \times 48 = 3360 \text{ ml}$$

It should be kept in mind that this calculated nominal total volume may vary from the actual total volume because of variations in the actual volume of each individual sample from the programmed nominal sample volume.

### Time example

After the volume of each individual sample and the total number of samples to be collected have been determined, the sampler may be programmed for automatic operation in a composite time mode by the use of the following set of step-by-step instructions. These instructions assume that the sampler is off, and that a composite sample container has been installed, as described in section 3.3.4.

STEP NO.	PROGRAM QUANTITY TO BE SET	DISPLAY
1. Press ON key. Places the sampler into the standby state.	1. None	1. STANDBY legend on. This alternates between time or flow pulse interval to next sample ("0014"* - TIME or FLOW legend), and the number of composite samples collected (" 45"* - COMP legend); if sampling previously completed, text "FULL" will be added to the alternation of the display.
2. Press PROGRAM/STEP key. This places the sampler into the program state.	2. MODE	2. Alternates between PRGM STEP 1 and previously programmed mode (" 2"*). PRGM legend is on as long as sampler remains in program state. FLOW* legend on.
3. Enter mode 1 (TIME) on the numeric keypad.	3. MODE	3. " 1"
4. Press ENTER VALUE key.	4. MODE	4. Alternates between PRGM STEP 1 and newly entered mode (" 1"). TIME legend is on as long as sampler remains in program state.
5. Press PROGRAM/STEP key.	5. INTERVAL BETWEEN SAMPLES	5. Alternates between PRGM STEP 2 and previously programmed interval in minutes (" 30"*).
6. Enter on the numeric keypad the desired interval between samples in minutes (up to 9999 minutes). For example, assume it is desired to collect samples at 15 minute intervals -- enter 15 on the numeric keypad.	6. INTERVAL BETWEEN SAMPLES	6. " 15"

## MODEL 2900

STEP NO.	PROGRAM QUANTITY TO BE SET	DISPLAY
7. Press ENTER VALUE key.	7. INTERVAL BETWEEN SAMPLES	7. Alternates between PRGM STEP 2 and newly entered interval in minutes (" 15").
8. Press PROGRAM/STEP key.	8. DELAY TO FIRST/NEXT SAMPLE	8. Alternates between PRGM STEP 3 and present interval to the next sample in minutes (" 11").
9. Enter on the numeric keypad the desired delay until the first sample is collected in minutes (up to 9999 minutes).  Note that this is the time interval from the present time until the time when it is desired to collect the first sample. For example, assume that it is presently 7:15 a.m., and it is desired to collect the first sample at 8:00 a.m. -- enter 45 on the numeric keypad.	9. DELAY TO FIRST/NEXT SAMPLE	9. " 45"
10. Press ENTER VALUE key.	10. DELAY TO FIRST/NEXT SAMPLE	10. Alternates between PRGM STEP 3 and present interval to the next sample in minutes (" 45").
11. Press PROGRAM/STEP key.	11. NOMINAL SAMPLE VOLUME	11. Alternates between PRGM STEP 4 and previously programmed nominal sample volume in 10's of ml (" 70").
12. Enter on the numeric keypad the desired sample volume in 10's of milliliters (to a maximum of 50). For example, assume that it is desired to collect samples with a volume of 40 ml -- enter 4 on the numeric keypad.	12. NOMINAL SAMPLE VOLUME	12. " 7"
13. Press ENTER VALUE key.	13. NOMINAL SAMPLE VOLUME	13. Alternates between PROGRAM STEP 4 and newly entered sample volume in 10's of ml (" 7").
14. Press PROGRAM/STEP key.	14. TYPE OF SUCTION LINE	14. Alternates between PRGM STEP 5 and previously programmed type of suction line (" 1").
15. Enter on the numeric keypad the number corresponding to the desired type of suction line. For example, assume that a 3/8" ID X 10' long suction line is being used -- enter type 3 (3/8" ID X 10') on the numeric keypad.	15. TYPE OF SUCTION LINE	15. " 3"
16. Press ENTER VALUE key.	16. TYPE OF SUCTION LINE	16. Alternates between PRGM STEP 5 and newly entered type of suction line (" 3").

## MODEL 2900

STEP NO.	PROGRAM QUANTITY TO BE SET	DISPLAY
17. Press PROGRAM/STEP key.	17. SUCTION HEAD	17. Alternates between PRGM STEP 6 and previously programmed suction head in feet (" 10"*).
18. Enter on the numeric keypad the suction head in feet, to a maximum of 20 ft. The suction head is the vertical distance from the surface of the liquid source to the pump inlet. For example, assume that the suction head in 8 ft. -- enter 8 on the numeric keypad.	18. SUCTION HEAD	18. " 8"
19. Press ENTER VALUE key.	19. SUCTION HEAD	19. Alternates between PRGM STEP 6 and newly entered suction head in feet (" 8").
20. Press PROGRAM/STEP key.	20. NUMBER OF SAMPLES	20. Alternates between PRGM STEP 10 and newly entered suction head in feet (" 8").
21. Enter on the numeric keypad the desired total number of individual samples which make up the composite sample. For example, assume that it is desired to composite 48 individual samples -- enter 48 on the numeric keypad	21. NUMBER OF SAMPLES	21 " 48"
22. Press ENTER VALUE key.	22. NUMBER OF SAMPLES	22. Alternates between PRGM STEP 10 and newly entered number of samples (" 48").
23. Press PROGRAM/STEP key. This returns the sampler to the standby state.	23. None	23. STNDBY legend on. Alternates between time interval to next sample ("0014"* - TIME legend) and number of composite samples collected (" 45"* - COMP legend); if sampling previously completed, text "FULL" will be added to the alternation of the display.
* EXAMPLE - may be other value		

### Operation in composite time mode

This completes the programming of the Model 2900 Sampler in composite time mode. Following the example, after the initial delay of 25 minutes from the moment the 25 minute delay was entered in step 9, the sampler will place the first individual sample in the composite container at 12:00 noon. The display will continue to alternate between the time in minutes remaining until the next sample is collected (for example, "0011" - TIME legend) and the total number of individual samples which have been placed in the composite container (for example, " 36" - COMP legend). After the first sample has been collected, the time interval to the next sample will be reset to the programmed value of 15 and will continue decrementing. When it decrements to zero, a sample will be collected, the display will be reset to the programmed value of 15, and the decrementing process will be started again. The process of placing individual samples into the composite container will continue until the 48th and last sample is placed in the container (after a 24 hour period), at which time the sampler will shut-off and the display will alternate between the text "FULL" and the total number of samples collected (" 48" - COMP legend).

**2.2.5.4 Composite Flow** - The object of composite flow sampling using the Model 2900 is to collect a series of discrete, equal volume samples at a known, regular flow interval, and to place these samples into a single composite sample container. The Model 2900 will accept flow proportional inputs of



## MODEL 2900

a certain specific nature from an external flow meter. These electronic flow input signals are transmitted to the sampler at fixed increments of total flow, for example every 10,000 gallons. That is, each time 10,000 gallons of liquid has flowed past the flow meter, a signal is sent to the sampler, which registers it as a single flow pulse. The Model 2900 Sampler can be programmed to totalize any number of flow pulses from 1 to 9999 before a sampling cycle is initiated. For example, if the sampler were programmed to totalize 5 flow pulses and each flow pulse represented 10,000 gallons of total flow, a sample would be collected each time 50,000 gallons (5 flow pulses of 10,000 gallons each) had flowed past the flow meter.

**Programming calculations** When programming the sampler in a composite flow mode, three quantities must be calculated to allow the sampler to be programmed in a rational manner: the flow volume increment between samples (number of flow pulses), the total number of samples to be collected, and the volume of each individual sample.

**Calculation of flow increment between samples** To calculate the flow increment between samples, the average flow rate of the flow stream and either the desired average time interval between individual samples or the total desired number of individual samples to be collected over the sampling period must be known. If the desired average time interval known between individual samples is known, the flow increment between samples can be determined by calculating how much flow, based on the average flow rate) occurs during that time interval. For example, assume that the average flow is 2.5 MGD and it is desired to collect a sample every 30 minutes, based on this flow. The flow increment between samples is calculated:

$$2.5 \text{ MGD} = 2,500,000 \text{ gallons/day}$$

$$2,500,000 \text{ gallons/day} \times 1 \text{ day/24 hours} \times 1 \text{ hour/60 minutes} = 1736.11 \text{ gallons/minute}$$

$$1736.11 \text{ gallons/minute} \times 30 \text{ minutes/sample} = 52,083 \text{ gallons/sample}$$

Thus, the desired flow increment between samples is approximately 52,000 gallons.

Alternatively, if the total number of samples to be collected over the total sampling period is known, the flow increment known between samples can be determined by calculating how much total flow will occur during the sampling period, and dividing this by the total number of samples to be collected. For example, assume that the average flow is 1.75 MGD, that the composite sampling period is 2 days, and that it is desired to collect 100 individual samples. The flow increment between samples is calculated:

$$1.75 \text{ MGD} = 1,750,000 \text{ gallons/day}$$

$$1,750,000 \text{ gallons/day} \times 2 \text{ days} = 3,500,000 \text{ gallons}$$

$$3,500,000 \text{ gallons}$$

$$3,500,000 \text{ gallons} \div 100 \text{ samples} = 35,000 \text{ gallons per sample}$$

Thus, the desired flow increment between samples is approximately 35,000 gallons.

**Calculation of number flow pulses**

Once the desired flow increment between samples is known, the number of flow pulses to be programmed into the sampler may be calculated, assuming that the volume of the flow pulses from the flow meter is known. The number of flow pulses is calculated by dividing the flow increment between samples by the volume of each flow pulse. Using the first example above, the flow increment between samples was calculated as 52,000 gallons; assume that each flow pulse represents 10,000 gallons of flow. The number of flow pulses to be programmed into the sampler is calculated:

$$52,000 \text{ gallons} \div 10,000 \text{ gallons/flow pulse} = 5.2 \text{ flow pulses}$$

## MODEL 2900

Rounding this to an even number results in 5 flow pulses to be programmed into the sampler. This in turn results in a flow increment between samples of 50,000 gallons (5 flow pulses X 10,000 gallons/flow pulses).

Calculation of total number of samples

To calculate the total number of samples to be collected, three quantities must be known: the average flow rate, the flow of samples increment between samples (calculated above), and the total time over which the composite sample is to be collected. The total number of samples to be collected is determined by first calculating the total flow volume over the sampling period, and then dividing this by the flow increment between samples. For example, assume that the average flow is 2.5 MGD, the flow increment between samples is 50,000 gallons, and the composite sample is to be collected over a 24 hour period. The total flow volume over a 24 hour period is:

$$2.5 \text{ MGD} = 2,500,000 \text{ gallons/day}$$

$$2,500,000 \text{ gallons/day} \times 1 \text{ day} = 2,500,000 \text{ gallons}$$

The total number of samples to be collected in this 24 hour period is then calculated:

$$2,500,000 \text{ gallons} \div 50,000 \text{ gallons/sample} = 50 \text{ samples}$$

Thus, based on an average flow of 2.5 MGD, 50 samples will be collected.

Calculation of sample volume

To calculate the volume of each individual sample, the volume of the composite sample container being used and the total number of samples to be collected (calculated above) must be known. Isco provides a 1 gallon (3,785 ml) container for use with the Model 2900.

The individual sample volume is calculated by simply dividing the volume of the composite sample container being used by the total number of samples to be collected. For example, assume that a total of 50 samples are to be collected in the one gallon container. The individual sample volume is then calculated:

$$3785 \text{ ml} \div 25 \text{ samples} = 151.4 \text{ ml/sample}$$

Thus, a sample volume of 150 ml (the next smaller volume which may be programmed on the Model 2900) will result in the desired composite sample. It is important to select an individual sample volume which will not result in an overfilled sample container under worst-case conditions. Because of the basic uncertainty of the considerations delivered sample volume exactly matching the programmed nominal sample volume and the  $\pm 10$  ml sample repeatability, it is good practice to select a nominal sample volume which is slightly smaller than the calculated sample volume. This is to prevent overfilling of the sample container. In the example, an individual nominal sample volume of 150 ml is a prudent choice because it will not result in an overfilled container. For critical applications, it may be useful to use the calibrate sample volume mode, as described in section 2.2.6.1.

Calculation of total sample volume

The nominal volume of the composite sample may be calculated by multiplying the programmed nominal sample volume by the total volume number of samples to be collected. In the example:

$$150 \text{ ml/sample} \times 25 \text{ samples} = 3750 \text{ ml}$$

It should be kept in mind that this calculated nominal total volume may vary from the actual total volume because of variations in the actual volume of each individual sample from the programmed nominal sample volume, and the total time to collect the 25 individual samples may vary from the desired time period because of variations in the average flow rate used for calculations.

Flow example

After the flow volume increment between samples (number of flow example pulses), the total number of samples to be collected, and the volume of each individual sample have been determined, the sampler may be programmed for automatic operation in a composite flow mode by the use of the following set of step-by-step instructions. These instructions assume

## MODEL 2900

that the sampler is off and that the composite sample container has been installed, as described in section 3.3.4.

STEP NO.	PROGRAM QUANTITY TO BE SET	DISPLAY
1. Press ON key. Places the sampler into the standby state.	1. None	1. STANDBY legend on. This alternates between time or flow pulse interval to next sample ("0014"* - TIME or FLOW legend), and the number of composite samples collected (" 45"* - COMP legend); if sampling previously completed, text "FULL" will be added to the alternation of the display.
2. Press PROGRAM/STEP key. This places the sampler into the program state.	2. MODE	2. Alternates between PRGM STEP 1 and previously programmed mode (" 2"*). PRGM legend is on as long as sampler remains in program state. FLOW* legend on.
3. Enter mode 6 (COMPOSITE FLOW) on the numeric keypad.	3. MODE	3. " 6"
4. Press ENTER VALUE key.	4. MODE	4. Alternates between PRGM STEP 1 and newly entered mode (" 6"). FLOW legend is on as long as sampler remains in program state.
5. Press PROGRAM/STEP key.	5. INTERVAL BETWEEN SAMPLES	5. Alternates between PRGM STEP 2 and previously programmed interval in flow pulses (" 15"*).
6. Enter on the numeric keypad the desired interval between samples in flow pulses (up to 9999 flow pulses). For example, assume it is desired to collect samples at 150,000 gallon intervals and each flow pulse represents 10,000 gallons -- enter 5 (50,000/10,000 = 5) on the numeric keypad.	6. INTERVAL BETWEEN SAMPLES	6. " 5"
7. Press ENTER VALUE key.	7. INTERVAL BETWEEN SAMPLES	7. Alternates between PRGM STEP 2 and newly entered interval in flow pulses " 5").
8. Press PROGRAM/STEP key.	8. NOMINAL SAMPLE VOLUME	8. Alternates between PRGM STEP 4 and previously programmed nominal sample volume in 10's of ml (" 50"*).
9. Enter on the numeric keypad the desired sample volume in 10's of milliliters (to a maximum of 99). For example, assume that it is desired to collect samples with a volume of 150 ml -- enter 15 on the numeric keypad.	9. NOMINAL SAMPLE VOLUME	9. " 15"
10. Press ENTER VALUE key.	10. NOMINAL SAMPLE VOLUME	10. Alternates between PROGRAM STEP 4 and newly entered sample volume in 10's of ml (" 15").

## MODEL 2900

STEP NO.	PROGRAM QUANTITY TO BE SET	DISPLAY
11. Press PROGRAM/STEP key.	11. TYPE OF SUCTION LINE	11. Alternates between PRGM STEP 5 and previously programmed type of suction line (" 3"*).
12. Enter on the numeric keypad the number corresponding to the desired type of suction line. For example, assume that a 3/8" ID X 25' long suction line is being used -- enter type 4 (3/8" ID X 25') on the numeric keypad.	12. TYPE OF SUCTION LINE	12. " 4"
13. Press ENTER VALUE key.	13. TYPE OF SUCTION LINE	13. Alternates between PRGM STEP 5 and newly entered type of suction line (" 4").
14. Press PROGRAM/STEP key.	14. SUCTION HEAD	14. Alternates between PRGM STEP 6 and previously programmed suction head in feet (" 10"*).
15. Enter on the numeric keypad the suction head in feet, to a maximum of 20 ft. The suction head is the vertical distance from the surface of the liquid source to the pump inlet. For example, assume that the suction head in 18 ft. -- enter 18 on the numeric keypad.	15. SUCTION HEAD	15. " 18"
16. Press ENTER VALUE key.	16. SUCTION HEAD	16. Alternates between PRGM STEP 6 and newly entered suction head in feet (" 18").
17. Press PROGRAM/STEP key.	17. NUMBER OF SAMPLES	17. Alternates between PRGM STEP 10 and newly entered suction head in feet (" 75").
18. Enter on the numeric keypad the desired total number of individual samples which make up the composite sample. For example, assume that it is desired to composite 25 individual samples -- enter 25 on the numeric keypad.	18. NUMBER OF SAMPLES	18 " 25"
19. Press ENTER VALUE key.	19. NUMBER OF SAMPLES	19. Alternates between PRGM STEP 10 and newly entered number of samples (" 25").
20. Press PROGRAM/STEP key. This returns the sampler to the standby state.	20. None	20. STNDBY legend on. Alternates between time interval to next sample ("0014"* - FLOW legend) and number of composite samples collected (" 45"* - COMP legend); if sampling previously completed, text "FULL" will be added to the alternation of the display.
21. Press the START SAMPLING key. This places the sampler in the run state.	21. None	21. RUN legend on. Alternates between flow pulse interval until the first/next sample is collected (" 5"* - FLOW legend) and the total number of composite samples which have been collected (" 0"* - COMP legend).

\* EXAMPLE - may be other value

## MODEL 2900

### Operation in

This completes the programming of the Model 2900 Sampler in the flow mode composite flow mode. Following the example, the sampler will place the first individual 150 ml sample in the composite sample container after 5 flow pulses (50,000 gallons) have been received from the external flow meter. The display will continue to alternate between the interval in flow pulses remaining until the next sample is collected (for example, "0004" - FLOW legend) and the total number of individual samples which have been placed in the composite container (for example, " 14" - COMP legend). The flow pulse interval to the next sample is reset to the programmed value of 5 when the START PROGRAM key is pressed in step 21. As flow pulses are received from the external flow meter, the flow pulse interval to the next sample shown in the display will decrement to zero, at which point a sample will be collected, the display will be reset to the programmed value of 5, and the decrementing process will begin again as flow pulses are received. The process of placing 150 ml samples into the composite container will continue until the 25th and last sample is placed in the container, at which time the sampler will shut off and the display will rotate between the text "FULL" and the total number of samples collected (" 25" - COMP legend).

**2.2.6 Advanced Programming** - The following four sections describe in detail some advanced programming techniques for the Model 2900 Sampler. As described in section 2.2.5, the time and flow modes typically account for the vast majority of sampling applications. However, special applications or situations may require the use of the "advanced" programming techniques described in the following sections. These techniques are described separately from the "standard" programming techniques so as not to add unnecessary and potentially confusing material to the programming procedures normally used.

### Advanced programming techniques

Included are sections describing an alternate method of selecting the sample volume, the modes available in the sampler for use with the Model 1640 Liquid Level Sampler Actuator, the use of the program HALT and RESUME keys, and the program lock feature. To fully understand the advanced programming techniques discussed in the following sections, the reader should be thoroughly familiar with the introductory material on programming and the sampler's controls, presented in section 2.2.1 through 2.2.4, and the standard programming techniques presented in section 2.2.5.

**2.2.6.1 Calibrate Sample Volume** - The normal method of selecting the sample volume, as described in section 2.2.5, is to program into the sampler the desired nominal sample volume, the type of suction line being used, and the applicable suction head. The calibrate sample volume mode offers an alternative method of selecting the sample volume. The calibrate sample volume mode is used to precisely the delivered sample volume precisely for a given set up of the sampler. It is useful when very accurate sample volume determination is necessary (for example, when using the samples per bottle multiplex mode), or when nonstandard sampling conditions are encountered (typically, a nonstandard suction line length).

### Overview of calibration process

The calibrate sample volume mode is selected by entering a zero when PRGM STEP 4 (NOMINAL SAMPLE VOLUME) is shown on the display. Then, when PRGM STEP 7 (CALIBRATE SAMPLE VOLUME) is shown on the display in its expected order in the programming sequence, the delivered sample volume may be directly calibrated. Briefly, to calibrate the sample volume, the sampler is set up exactly as it will be used, and the pump tubing is removed from the distributor arm and placed in a graduated cylinder.

Then, using the PUMP JOG REV and PUMP JOG FWD keys, a suction line prepurge, a suction line and bottle fill, and a suction line postpurge are programmed by pumping the desired amount of sample volume into the graduated cylinder. The number of volume counts associated with each segment of the sampling cycle will be shown in the display as it is being programmed, along with a "P" (for Purge) or "F" (for Fill) and a numeric designator to identify the segment being programmed. Up to five complete purge-fill-purge cycles may be programmed, allowing for suction line preconditioning or other special sampling cycles. The end of the sampling cycle is marked by entering a volume count value of zero on the NUMERIC KEYPAD for either a purge or fill cycle as desired.

## MODEL 2900

Preparation of the sampler for calibration	<p>In detail, the sample volume is calibrated as follows. If it is known that a calibrate sample volume mode of operation is to be used, the sampler should be physically prepared before the programming process is started. This is done by placing the sampler in the location in which it will be used, attaching the suction line which will be used to the pump, and placing the inlet end of the suction line in its final position in the flow stream. Then, remove the pump tube from the distributor arm (refer to section 3.2). This is accomplished by disconnecting power from the unit, separating the center section from the remainder of the sampler (as described in section 2.1.1), and turning the center section over, as shown in Figure 3.2-1.</p>
Optional graduated cylinder	<p>Unscrew the distributor arm retaining nut, as shown in Figure 3.2-1, and pull the arm off the distributor shaft. The pump tube may then be pulled out of the distributor arm. Next, turn the center section back over, pull the tube out of the pump tube port indicated in Figure 3.2-1, and replace the center section on the sample bottle tub. Finally, place the end of the tube over a graduated cylinder. A 1000 ml plastic graduated cylinder is optionally available for sample volume calibration; however, any cylinder of sufficient volume graduated in cc's or ml's may be used.</p>
Sample volume calibration mode selection	<p>After a sampler has been physically prepared for the sample volume calibration process, the sampler may be programmed. As noted, the sample volume calibrate mode of operation is selected by entering a zero when PRGM STEP 4 (NOMINAL SAMPLE VOLUME) is shown on the display. Then, when PRGM STEP 7 (CALIBRATE SAMPLE VOLUME) is shown on the display during programming, the volume calibration may be made. Before describing the calibration process, three items need to be discussed. First, during the calibration process, a number termed "volume counts" will be shown in the display. The number of volume counts is directly related to rotations of the peristaltic pump rotor. It is displayed to provide a frame of reference and to allow direct keyboard entry of volume counts for previously calibrated setup conditions. However, it is not practical to directly relate the number of volume counts to a number of milliliters of delivered volume. It is best to consider the volume count as an arbitrary, dimensionless number. Second, it should be kept in mind that the sampler's pump constitutes the major source of sampler power consumption. If the sampler is being powered by a battery, some care should be exercised not to calibrate in unnecessarily long pre- and postpurge cycles. This could lead to an unnecessary current drain on the battery. Third, calibration should be completed with as little delay as possible between the various sampling cycles. This is to prevent draining of the tubing which would not occur during a normal sampling cycle.</p>
Volume counts	
Calibration of sample volume	<p>When the calibrate sample volume mode of operation has been selected, the presence of the text PRGM STEP 7 (CALIBRATE SAMPLE VOLUME) on the display signifies that the volume calibration can be made. Initially, the display will alternate between a previously programmed number of volume counts (for example, " 250") and a PO ("PO--"), indicating that the number of volume counts shown represents the number of volume counts for the initial purge cycle (the prepurge). The prepurge cycle is calibrated by turning the pump on using the PUMP JOG REV key. Holding the PUMP JOG REV key down causes the alternation of display to cease, the display to be reset to zero, and the pump to be turned on in reverse, providing an air prepurge of the line and intake. The number of volume counts registered for the prepurge will be shown on the display as they are accumulated. When the desired prepurge has been obtained, releasing the PUMP JOG REV key will cause the pump to stop. The typical duration of a prepurge is only a few seconds, since its purpose is to clear any accumulated debris from the inlet of the suction line. However, a very heavily laden flow stream may require a longer prepurge. If a satisfactory prepurge is not obtained, press the CLEAR ENTRY key and repeat the calibration process. After a satisfactory prepurge has been obtained, pressing the ENTER VALUE key will cause the number of prepurge volume counts to be loaded into the sampler's memory, and restores the display's alternation between the newly calibrated number of prepurge counts and "PO--". Alternatively, if the number of volume counts for the prepurge is known from a previous calibration process, a prepurge value of 0 to 9999 volume counts may be entered on the numeric keypad. As soon as the first numeric key is pressed, the alternation of the display will stop and the prepurge number will be shown on the display as it is entered. Note that for the initial purge cycle only (the prepurge) a zero is a valid entry for the number of volume counts. Since the prepurge is not absolutely necessary, it may be left off in applications where battery life is critical. After the desired number of prepurge volume counts has been entered, pressing the ENTER VALUE</p>
Prepurge	

## MODEL 2900

key will load the new number of counts into the sampler's memory and restore the display's alternation between the newly entered number of counts and "PO--". After the correct number of prepurge volume counts has been obtained, either by keyboard entry or by using the PUMP JOG REV key, the display may be stepped to the next quantity to be calibrated by pressing the PROGRAM/STEP key. If the number of prepurge volume counts initially shown on the display is known to be correct, for example, from a previous calibration process, it may be retained by pressing the PROGRAM/STEP key. This also will cause the display to be stepped to the next quantity to be set. It should be noted that instead of using the sequence of loading the newly entered number of prepurge volume counts into the sampler's memory using the ENTER VALUE key and then stepping to the next quantity to be programmed, both functions may be accomplished by pressing the PROGRAM/STEP key, since it contains an implied ENTER VALUE function.

### Line and bottle fill

After the prepurge has been loaded by pressing the PROGRAM/STEP key, the display will alternate between a previously programmed number of volume counts (for example, "1000") and an F1 ("F1--"), indicating that the number of volume counts shown represents the number of volume counts for the first line and bottle fill cycle. The line and bottle fill cycle is calibrated by holding the outlet of the pump tube at the bottom of the graduated cylinder and turning the pump on using the PUMP JOG FWD key. Locating the end of the tube in the bottom of the cylinder reduces turbulence, allowing more accurate determination of the volume of liquid. Holding the PUMP JOG FWD key down causes the alternation of the display to cease, the display to be reset to zero, and the pump to be turned on in the forward direction, causing the suction line to be filled with liquid and a sample to be placed in the graduated cylinder. The number of volume counts registered for the line and bottle fill will be shown on the display as they are accumulated. When the desired sample volume has been obtained in the graduated cylinder, releasing the PUMP JOG FWD key will cause the pump to stop. If too much sample volume was obtained, the excess may be pumped out of the graduated cylinder using the PUMP JOG REV key. After a satisfactory line and bottle fill has been obtained, pressing the ENTER VALUE key will cause the number of fill volume counts to be loaded into the sampler's memory, and restores the display's alternation between the newly calibrated number of fill counts and "F1--". Alternatively, if the number of volume counts for the line and bottle fill is known from a previous calibration process, a fill value of 1 to 9999 volume counts may be entered on the numeric keypad, as described for the prepurge. The remainder of the procedure is also the same as for the prepurge.

### Postpurge

After the first line and bottle fill has been loaded by pressing the PROGRAM/STEP key, the display will alternate between a previously programmed number of volume counts (for example, "500") and a P1 ("P1--"), indicating that the number of volume counts shown represents the number of volume counts for the first Postpurge cycle. The postpurge cycle is calibrated by removing the pump tube from the graduated cylinder and turning the pump on using the PUMP JOG REV key. Holding the PUMP JOG REV key down causes the alteration of the display to cease, the display to be reset to zero, and the pump to be turned on in reverse, forcing the liquid out of the suction line. The number of volume counts registered for the postpurge will be shown on the display as they are accumulated. When the desired postpurge has been obtained, releasing the PUMP JOG REV key will cause the pump to stop. The typical duration of the postpurge is the number of volume counts sufficient to clear the suction line. This may be determined by watching for bubbles to flow from the inlet of the suction line. If a satisfactory postpurge is not obtained, press the CLEAR ENTRY key and repeat the calibration process. After a satisfactory postpurge has been obtained, pressing the ENTER VALUE key will cause the number of postpurge volume counts to be loaded into the sampler's memory, and restores the display's alternation between the newly calibrated number of postpurge counts and "P1--". Alternatively, if the number of volume counts for the postpurge is known from a previous calibration process, a postpurge value of 1 to 9999 volume counts may be entered on the numeric keypad, as described for the prepurge. The remainder of the procedure is also the same as for the prepurge.

### Marking the end of the sampling cycle

After the first postpurge has been loaded by pressing the PROGRAM/STEP key, the display will alternate between a previously programmed number of volume counts (for example, "0") and an F2 ("F2--"), indicating that the number of volume counts shown represents the number of volume counts for the second line and bottle fill cycle. At this point, a normal complete sampling cycle, consisting of a prepurge, a line and bottle fill of the desired volume, and a postpurge, has been programmed into the sampler. The end of the normal sam-

## MODEL 2900

pling cycle is marked by entering a volume count value of zero on the numeric keypad for the second fill cycle. After a zero has been entered, pressing the PROGRAM/STEP key will cause the sampler to be transferred to the standby state.

Up to five fill--purge cycles

However, if desired, the first postpurge cycle may be followed by another fill cycle, followed by another postpurge cycle, etc., up to a total of five complete fill--postpurge cycles (F5, P5). These fill and postpurge cycles are calibrated or directly entered as described above. The end of a sampling cycle is always marked by entering a volume count value of zero on the numeric keypad for either a purge or fill cycle as desired. Additional cycles beyond the normal prepurge, line and bottle fill and postpurge are typically used to provide a suction line precondition mode of operation, although other uses are possible. Certain researchers have suggested that a suction line sample liquid flush prior to the actual sampling cycle may be desirable to eliminate cross-contamination due to residue in the suction line. A suction line precondition mode may be established using the calibrate sample volume functions by limiting the first fill cycle to filling the suction line just up to the inlet of the pump. This would then be followed by a normal postpurge, a normal line and bottle fill, and a final postpurge. If desired, the preconditioning suction line fill could be repeated several times. In operation, the suction line is actually flushed with the sample liquid one or more times, normalizing the concentration of pollutants in the suction line and eliminating the possibility of any cross-contamination from the previously collected sample.

Suction line precondition

Reassembly of sampler

After the sample volume calibration has been completed, the pump tube needs to be reinstalled in the distributor arm (refer to section 3.2). Feed the free end of the tube down through the pump tube port in the center section. Then, turn the center section over again, and feed the end of the tube into the body of the distributor arm, as shown in Figure 3.2-3,A. Next, feed the end of the tube into the outlet of the distributor arm, such that the end of the tube is flush with the end of the arm, as shown in Figure 3.2-3,B. Finally, reinstall the distributor arm on the distributor shaft and screw on the distributor arm retaining nut. Be sure that the nut is tight. As a final check, inspect the length of exposed tube under the center section; there should be no excessive slack in this tube.

Final check

As a final confirmation of the calibrated sample volume, a test sample may be collected using the MANUAL SAMPLE key. The volume of this sample should then be measured. If the desired sample volume is not obtained, repeat the calibration process, as described above.

Operation of CLEAR ENTRY key

In the calibrate sample volume mode, the behavior of the CLEAR ENTRY key is enhanced, in that when the display is alternating between a number of volume counts and a P or F designator, a depression of the CLEAR ENTRY key will cause the display to "back-up" to show the number of volume counts and the P or F designator of the previous purge or fill cycle. This enhancement has been added as a programming convenience; it allows a previously entered purge or fill cycle to be modified without stepping through the entire programming sequence. Backing up past the initial prepurge cycle will cause the sampler to be transferred to the standby state. When the display is not alternating, the CLEAR ENTRY key works in its normal manner.

**2.2.6.2 Liquid Level Sampler Actuator Modes** - The Model 2900 Sampler may be used with an Isco Model 1640 Liquid Level Sampler Actuator. The Model 1640 Actuator causes the sampler to remain dormant until the liquid level in a flow stream rises to a predetermined level, at which time the sampling program is initiated. The Model 2900 has three selectable modes in which the sampling program may be initiated when liquid touches the Actuator's probe.

Mode 1

A sample is collected immediately when liquid touches the Actuator's probe, and the interval to the next sample is reset to the programmed INTERVAL BETWEEN SAMPLES.

Mode 2

A sample is not collected when liquid touches the Actuator's probe and the interval to the next sample is not reset. In this mode, when the sampler is operating in one of the time modes, sampler time is decremented even when sample collection is inhibited by the Actuator; this permits synchronization of the sampling with real clock time. When the sampler is operating in one of the flow modes, flow pulses are not accepted until after liquid touches the probe.



## MODEL 2900

- Mode 3** A sample is not collected when liquid touches the Actuator's probe and the interval to the next sample is not reset. In this mode, when the sampler is operating in one of the time modes, sampler time does not start decrementing until water touches the Actuator's probe; thus, the programmed time delay to the first sample and the time interval between samples are both operative. When the sampler is operating in one of the flow modes, flow pulses are not accepted until after liquid touches the probe and the interval to the next sample is reset to the programmed interval. This is significant only when the Model 1640 is operating in the toggle mode.
- Use of Mode 1** Mode 1 is used when it is desired to collect a sample immediately when liquid touches the Actuator's probe and collect the remainder of samples at the programmed time or flow pulse interval between samples. Mode 2 is typically used in time mode when it is desired to delay the start of sampling until liquid touches the Actuator's probe and to synchronize the collection of samples with real clock time. Mode 3 is typically used in a time mode when it is desired to delay the start of sampling until liquid touches the Actuator's probe, and to use the programmed delay to the first sample and the interval between samples. Modes 2 or 3 are used in the flow mode when it is not desired to collect a sample when liquid touches the probe, but to subsequently collect samples at the programmed flow pulse interval.
- Use of Mode 2**
- Use of Mode 3**
- Programming of actuator mode** The mode of Liquid Level Sampler Actuator operation is selected by placing the sampler into what is essentially a special mode program state. For a sampler in the standby state, pressing the ENTER VALUE key five times in succession places the sampler into a program state where the mode of Actuator operation may be selected. This is indicated by PRGM STEP 88 being shown on the display. When PRGM STEP 88 is shown, the mode of Actuator operation previously programmed will be shown on the display. A number corresponding to the desired mode of Actuator operation (1, 2, or 3) may then be entered on the numeric keypad. The ENTER VALUE and CLEAR ENTRY keys work as in the normal program state. Pressing the PROGRAM/STEP key returns the sampler to the standby state.
- 2.2.6.3 Program Halt/Resume** - The HALT SAMPLING and RESUME SAMPLING keys are used to interrupt the program of a running sampler, allowing changes to be made to the program, and then permitting the program to be restarted, without resetting the distributor arm to the first bottle position. The program halt/resume sequence is typically used to modify the time interval between samples or timely interval to the first/next sample collection. However, it may be used to modify any of the program quantities, if, for example, they were originally programmed incorrectly, sampling conditions change, etc. The HALT SAMPLING key can also be used to access the metric units of measure mode.
- General halt/resume procedures** The general procedures for the use of the program halt/resume procedures are:
1. Halt the program by pressing the HALT SAMPLING key.
  2. Using the PROGRAM/STEP key, step to the desired program quantity (or quantities) to be changed, and make the change (or changes).
  3. Return the sampler to the standby state.
  4. Restart the program by pressing the RESUME SAMPLING key.
- Use of HALT SAMPLING KEY** Pressing the HALT SAMPLING key of a sampler in the run state will cause the sampling program which is in operation to be halted and will transfer the sampler to the standby state. This allows the sampler's program to be modified as desired using the standard programming techniques. If the sampler is operating in the time mode, time decrementing will continue even after the program has been halted. If the time interval to the next sample reaches zero while the program is halted, a sample will not be collected, the time interval to the next sample will be reset to the programmed interval, and time decrementing will continue. A missed sample will not be remembered and consequently will not be collected when the program is resumed. If the sampler is operating in the flow mode, flow pulse decrementing will cease until the program is resumed. If the HALT SAMPLING key is pressed while the sampler's pump is running, the pump will immediately stop.
- Use of RESUME** Pressing the RESUME SAMPLING key of a sampler in the standby state will cause the

## MODEL 2900

SAMPLING key  Only sample interval or delay changed	sampling program as it currently exists to begin execution. The distributor arm will not be reset to the bottle number one position. (This is one of the differences between the RESUME SAMPLING and START SAMPLING keys.) The RESUME SAMPLING key is normally used to resume the program of a previously running sampler whose program has been interrupted by the HALT SAMPLING key. If, during the time while the program was halted, no program quantities or only the interval between samples and/or the delay to the first/next sample were changed, the sampling program will be resumed, upon depression of the RESUME SAMPLING key, at the point where it was halted, according to the program quantities currently set. The exception to this is that, as noted above, the time interval to the next sample will continue to decrement while the program is halted; thus, the time interval to the first/next sample will probably be a smaller value when the program is resumed. This allows the sampling to remain in synchronization with real clock time and the time interval between samples to remain constant, providing that the interval to the first/next samples does not decrement to zero while the program is halted. The flow interval to the next sample, however, does not change during the halt; thus, under these conditions, the flow interval will be resumed at exactly the point where it was when sampling was halted.
Other program quantities	If, on the other hand, any program quantities other than the interval between samples or the interval to the first/next sample were changed during the program halt, behavior of the sampler upon program resumption depends upon two factors. First, if the sampler is operating in one of the multiplex modes, and the multiplex number is something other than one, when the RESUME SAMPLING key is pressed, the distributor will advance to the next bottle and the multiplex number will be reset to one. And second, if the program was halted during a sample collection (while the pump is running), when the RESUME SAMPLING key is pressed the suction line will be purged and the distributor advanced to the next bottle. Under these conditions, the time interval to the next sample behaves as described above. The flow interval to the next sample, though, will be reset to the programmed interval upon program resumption.
Inconsistent samples may result	It should be noted that changing program quantities during a program halt/resume sequence quite possibly may result in subsequent samples which are not consistent with the previously collected samples. Thus, before changing program quantities during a program halt, the user should be aware of the consequences of such a change on subsequent samples, and the inconsistencies which may result.

**2.2.6.3.1 Selecting Units of Measure** - The sampler's metric units of measure can be accessed by placing the sampler into a special program state. For a sampler in the standby state, pressing the HALT SAMPLING key five times in succession places the sampler into a program state where the units of measure (English or metric) can be selected. This is indicated by PRGM STEP 77 being shown on the display. When PRGM STEP 77 is shown on the display, the sampler's units of measure can be selected by entering the number 0 for English units or 1 for metric units on the numeric keypad and pressing the PROGRAM/STEP key. English units of measure are suction head in feet, volume in milliliters, and suction line length in feet. The metric units of measure will be head in decimeters, volume in milliliters, and suction line length in meters.

**2.2.6.4 Program Lock** - To prevent casual tampering with the program set in the Model 2900, a program lock feature has been included. When the sampler's lock is engaged, the sampler cannot be placed into a program mode and hence, the program cannot be changed. This allows the sampler to be programmed in the office, "locked," and then placed into operation in the field without the danger of the program being modified. It also prevents unauthorized individuals or vandals from tampering with the sampler's preset program.

The sampler's program lock is engaged by placing the sampler into what is essentially a special program state. For a sampler in the standby state, pressing the CLEAR ENTRY key five times in succession places the sampler into a program state where the program lock can be engaged. This is indicated by PRGM STEP 99 being shown on the display. When PRGM STEP 99 is shown on the display, the sampler's program lock may be engaged by entering the number "2900" on the numeric keypad and pressing the PROGRAM/STEP key. This engages the sampler's program lock (as indicated by the LOCK legend of display being on) and returns the sampler to the standby state. The ENTER VALUE and CLEAR ENTRY keys also work as in the normal program state; however, the program lock is not engaged (or disengaged) until the PROGRAM/STEP key is pressed. When the program lock is engaged,

## MODEL 2900

of the program control keys only the START SAMPLING, HALT SAMPLING, and RESUME SAMPLING keys are functional, allowing the program to be started and stopped, but not changed. The ON, OFF, and all the manual control keys remain functional, allowing the sampler to be manually controlled. As long as the program lock is engaged, the LOCK legend on the display will be on.

To disengage the program lock, the sampler must be in the standby state. The program lock may then be disengaged by following the same procedures used to engage the lock: press the CLEAR ENTRY key five times in succession, enter "2900" on the keypad, and press the PROGRAM/STEP key. This "toggles" the sampler out of the program lock; the LOCK legend on the display will go out. The sampler's program may then be changed as desired.

**2.3 Placing the Sampler into Operation** - In summary, to place the Model 2900 Sampler into operation, the preparational steps described in section 2.1 must be performed. The sample bottle tub must be prepared for use, the desired suction line attached, the suction line inlet properly placed in the liquid source, the sampler properly placed at the sampling site, a power source connected to the sampler, and an external flow meter (if used) properly interfaced with the sampler.

**Programming** After these preparational steps have been completed, the sampler may be programmed for automatic operation as described in section 2.2. The various program quantities must be set to select the mode of sampler operation, the interval between samples, the sample volume, etc.

**Internal-battery allows programming** Because the Model 2900 has an internal lithium battery providing continuous memory, the sampler may easily be programmed in the office or the lab, taken into the field, and placed into operation. In the field, the only program quantity that might need to be reprogrammed is the delay to first/next sample, to assure that the sampling program is started at the desired time. After the sampler has been properly prepared for use and programmed for operation, the sampling program is started by pressing the START SAMPLING key.

**Immediate collection of first sample** Often, it is desired to collect the first sample while the operator is still present, as a final check that everything is working. For a sampler operating in the time mode, this may be accomplished in two ways, depending upon whether or not it is desired to synchronize the samples with real clock time. If synchronization is desired, the first sample may be collected by assuring that the distributor is over the bottle number 1 position, pressing the MANUAL SAMPLE key (while the sampler is in the standby state), checking to be sure the delay to the first/next sample is set correctly to synchronize the samples with clock time, and then pressing the RESUME SAMPLING key. The first sample will be collected when the MANUAL SAMPLE key is pressed. The second sample will be collected when the programmed delay to the first/next sample times out, and subsequent samples will be collected at the programmed interval between samples. The second and remaining samples will be synchronized with real clock time; the first sample probably will not be, and there will probably be a nonuniform interval between the first and second samples. If synchronization is not required, the first sample may be collected while the operator is present by programming a delay to the first/next sample of one minute, and then pressing the START SAMPLING key. The first sample will then be collected in approximately one minute and subsequent samples at the programmed interval between samples.

**Flow mode** For a sampler operating in the sequential or composite flow modes, the collection of the first sample while the operator is present may be accomplished by pressing the MANUAL SAMPLE key (while the sampler is in the standby state), and then pressing the RESUME SAMPLING key. The first sample will be collected when the MANUAL SAMPLE key is pressed, and subsequent samples will be collected at the programmed flow pulse interval between samples.

**2.4 Sample Recovery** - The Model 2900 Sampler will automatically cease operation after all samples have been taken. When the sampler's program has been completed, the display will read "FULL." Because of the automatic shut-off, timing of the recovery of the samples is not critical.

**Recovering the entire sampler** When recovering the sampler, if it must be pulled from a manhole, be sure to keep it level to prevent spilling the collected samples. If the entire sampler is to be returned to the laboratory or office, disconnect the cable from the flow meter, if used. The sampler may be turned

## MODEL 2900

off, if desired, but this is not necessary. Separate the sample bottle tub from the center section, as described in section 2.1.1, and put caps on the bottles. The sampler is now ready to transport.

- Leave sampler on      If the entire sampler is not to be returned to the lab, but only sample bottle tubs exchanged and the sampling restarted, the sampler should not be turned off while exchanging bottle tubs. This is because no purpose is served by turning the unit off, and if the sampling is being done in a time mode in synchronization with real clock time, the synchronization is preserved as long as the sampler is left on. When exchanging bottle tubs, it is also good practice to consider the state of charge of the sampler's battery at this time, if one is being used. The charge duration of the sampler batteries is discussed in section 3.4.3. If the sampler's battery state of charge is questionable, it should be exchanged with a freshly charged battery.
- Check battery
- Exchanging sample tubs      The full sample bottle tub may be exchanged for an empty one by separating the tub from the center section as described in section 2.1.1, and installing an empty tub. After the full tub has been removed, place caps on all the bottles. Using the sample bottle tub as a carrying case is not only handy, it also aids in preventing mix ups in bottle order. An optional cover for the sample bottle tub is available to aid in transportation. The cover is attached to the tub in the same manner as the center section. It is good practice to label the sample bottle tub with an adhesive label detailing the location, time, date, etc., of sampling to avoid confusion.

---

### NOTE

**When cooling samples with ice, the melt water may cause the bottles to float when you remove the retaining ring.**

---

- Restarting the sampler      After the empty sample bottle tub has been installed, the sampling maybe restarted by pressing the START SAMPLING key. Note that it may be necessary to reprogram the delay to the first/next sample to start the sampling process at the desired time.

## MODEL 2900

### CHAPTER 3

**3.0 ROUTINE MAINTENANCE** - This third chapter of the Model 2900 presents instructions for the routine maintenance necessary to keep the sampler in top operating condition. Included are sections providing information on cleaning the sampler and components, replacing the pump and suction tubing, charging the optional batteries, and changing the internal desiccant.

Familiarization with maintenance procedures

It is strongly recommended that the user thoroughly familiarize himself or herself with the routine maintenance procedures presented in the following paragraphs. The Model 2900 Sampler, although ruggedly built to withstand difficult field operating conditions, will function best and maintain maximum reliability when these simple maintenance procedures are followed. As with any piece of field operated equipment, a certain amount of preventive maintenance is necessary to keep the sampler functioning properly.

**3.1 Cleaning the Sampler** - The following sections present instructions for cleaning the sampler case, sampler tubing, and sampler bottles, and cleaning protocols for priority pollutants.

**3.1.1 Case** - The top cover and tub may be cleaned by submersion in warm soapy water or by spraying them with a hose. The center section may also be cleaned in a similar manner provided that the FLOW METER external electrical connector is tightly capped and that the fuse holder is tightly screwed in place. It is good practice to minimize direct liquid contact with the control box. The sampler may be disassembled for cleaning by following the instructions found in section 2.1.1.

**3.1.2 Tubing** - The suction line and pump tubing may be cleaned by placing the end of the suction line in a cleaning solution and pumping this solution through the tubing system using the pump CONTROL keys (see section 2.2.3.1.1). Follow with a clean water rinse.

**3.1.3 Sample Bottles** - The polyethylene plastic sample bottles have a wide mouth to facilitate cleaning and are formed so that they have no inaccessible corners. The plastic bottles can be washed in a dishwasher, but not autoclaved. The 375 ml and 1 gallon glass containers also have a wide mount for easy cleaning; these containers can be washed in a dishwasher. The plastic lids should not be autoclaved.

**3.1.4 Cleaning Protocols for Priority Pollutants** - The following sections are excerpted from U.S. Environmental Protection Agency Publications EPA-600/4-77-039 ("Sampling of Water and Wastewater" by Dr. Phillip E. Shelley) to provide an example of sampler cleaning procedures for priority pollutants.

The proper cleaning of all equipment used in the sampling of water and wastewater is essential to ensuring valid results from laboratory analysis. Cleaning protocols should be developed for all sampling equipment early in the design of the wastewater characterization program. Here also, the laboratory analyst should be consulted, both to ensure that the procedures and techniques are adequate, as well as to avoid including practices that are not warranted in view of the analysis to be performed.

As an example, Lair (1974) has set down the standard operating procedures for cleaning sample containers and field equipment used by USEPA Region IV Surveillance and Analysis field personnel engaged in NPDES compliance monitoring. They are reproduced below for a typical automatic sampler and related sampling equipment.

#### Isco Glass Sample Containers

1. One spectro grade acetone rinse.
2. Dishwasher cycle (wash and tap water rinse, no detergent).
3. Acid rise with at least 20 percent hydrochloric acid.

## MODEL 2900

4. Dishwasher cycle, tap and distilled water rinse cycles, no detergent.
5. Replace in covered Isco bases.

### Suction Tubing (1/4, 3/8 Vinyl or Teflon)

1. Do not reuse suction tubing. No cleaning required. New suction tubing is to be used for each new sampling setup.
2. Use Teflon tubing where samples for organics are to be collected.

### Isco Pump Tube

1. Rinse by pumping hot tap water through tubing for at least 2 minutes.
2. Acid wash tubing by pumping as least a 20 percent solution of hydrochloric acid through tubing for at least 2 minutes.
3. Rinse by pumping hot tap water through tubing for at least 2 minutes.
4. Rinse by pumping distilled water through tubing for at least 2 minutes.

### Teflon Tubing

1. Rinse twice with spectro grade acetone.
2. Rinse thoroughly with hot tap water using a brush if possible to remove particulate matter and surface film.
3. Rinse thoroughly three times with tap water.
4. Acid wash with at least 20 percent hydrochloric acid.
5. Rinse thoroughly three times with tap water.
6. Rinse thoroughly three times with distilled water.
7. Rinse thoroughly with petroleum ether and dry by pulling room air through tubing.
8. Dry overnight in warm oven (less than 150°F) if possible.
9. Cap ends with aluminum foil.

**3.2 Replacement of Pump Tubing** - The pump tube provides two functions in the Model 2900 Sampler. First, it serves as a pump tube in the sampler peristaltic pump. Second, it serves as a distribution tube, routing the sample liquid from the pump outlet to the sample bottle. The pump tube consists of a single 35 inch (89 cm) long piece of a special silicone rubber tubing. This particular type of silicone rubber tubing is used because of its superior mechanical properties and because it does not contain any organic materials. This latter point is extremely important if samples are to be collected in which organic materials are of interest. Other types of silicone rubber tubing may contain organic materials which are used as vulcanizing agents. During the vulcanizing process, these compounds are converted into other compounds which may be leached by the sample. Therefore, if another silicone tubing is used in the pump, the sample may be contaminated with organic compounds leached from the pump tubing. The silicone rubber tubing supplied by Isco for use with the Model 2900 will not contribute any organic material to the sample.

#### Inspection of pump tubing

The silicone rubber tubing is reliable and long-lived. However, due to the constant mechanical strain placed on the tubing by the peristaltic action of the pump, it will eventually fatigue and fail. It is good practice to periodically remove the outer pump case half (as described below) and inspect the tubing for wear, replacing it with the spare pump tube included with the sampler if necessary. Additional pump tubing sections are available from

## MODEL 2900

Isco. If the liquid being sampled contains a high percentage of fairly large suspended solids, the inspections should be fairly frequent. If the liquid is relatively free of solids, the inspections may be less frequent. Note that since the amount of tubing (13.5 inches) actually used in the pump is less than half of the total length of the pump tube (35 inches), in certain cases the tube may be used twice in the pump by simply turning it around. This is possible, of course, only if the portion of the tube previously used in the pump has not been split or otherwise damaged to the point of leaking.

- Removing the distributor arm** The first step in replacing the pump tube is to remove it from the distributor arm located on the underside of the center section. This is done by disconnecting power from the unit, separating the center section from the remainder of the sampler (as described in section 2.1.1), and turning this section over, as shown in Figure 3.2-1. Unscrew the distributor arm retaining nut, indicated in Figure 3.2-1, and pull the arm off the distributor shaft. The pump tube may then be pulled out of the distributor arm. Finally, turn the center section back over, and pull the tube out of the pump tube port, indicated in Figure 3.2-1.
- Removing the pump tube** The pump tube may now be removed from the pump itself. First remove the outer pump case half by loosening the four captivated thumbscrews indicated in Figure 2.1-2. This will expose the pump tubing which is squeezed between the pump rollers and the curved surface of the inner pump case half. Extract the tubing and the pump tubing guide and clamp assemblies from the inner case half. Then, loosen and remove the pump tubing guide and clamp assemblies from the pump tube. Remove the suction line, if attached, as described in section 3.3 below. This completes the removal of the old pump tube.
- Installing a new pump tube** To install the new pump tube, first reinstall the suction line, as described in paragraph 2.1.4. Then, replace and tighten the pump tubing guide and clamp assemblies, as shown in Figure 3.2-2. Be sure that pump tubing guide and clamp assembly at the outlet end of the pump tubing is positioned at the edge of the black band on the pump tube. The edge of the black band is located 13.5 inches (34.3 cm) from the inlet end of the pump tube and is used for placement of the outlet pump tubing guide and clamp assembly. This placement is critical to prolong the life of the pump tube and to assure efficient operation and accurate delivery volumes.
- Installation in the pump** The pump tubing guide and clamp assemblies may now be replaced in the pump in the inner pump case half so that their grooves mate with the semi-circular openings in the pump case, with the black band on the top of the pump. Slip the pump tubing under the rollers so that the pump tubing does not interfere with the installation of the outer pump case half. Replace the outer pump case half so that the grooves of the pump tubing guide and clamp assembly fit properly into both halves of the pump, and tighten the four thumbscrews.
- Installation in the distributor arm** Next, feed the free end of the tube down through the tube port in the center section. Then, turn the center section over again, and feed the end of the tube into the body of the distributor arm, as shown in Figure 3.2-3,A. Next, feed the end of the tube into the outlet of the distributor arm, such that the end of the tube protrudes 1/8" beyond the end of the distributor arm, as shown in Figure 3.2-3,B. Finally, reinstall the distributor arm on the distributor shaft and screw on the distributor arm retaining nut. Be sure that the retaining nut is tight. This completes the installation of the new pump tube. As a final check, inspect the length of exposed tube under the center section. There should be no excessive slack in this tube; it should be installed such that it continuously slopes downward from the bottom of the center section to the point where it enters the distributor arm. This is, of course, to prevent any low spots in the tube which might not completely drain of sample liquid. If there is any excessive slack, adjust the length of the tubing under the center section by pulling tube out of the pump tube port.
- Maximizing tubing life** To maximize pump tubing life and pumping efficiency, it is very important to maintain 13 to 13-1/2 inches of tubing inside the pump. This may normally be accomplished by carefully following the above instructions and correctly positioning the black band on the pump tube. However, as a final check, the following procedure may be followed. After the new pump tube has been installed as above, loosen the clamp on the top (outlet) of the pump. Then, using the PUMP JOG FWD key, run the pump briefly, allowing the pump tubing to "seek" correct positioning in the pump. While the pump is still running, retighten the top clamp. The pump tube should now be correctly installed.

MODEL 2900

Figure 3.2-1 Removal of the Pump Tube

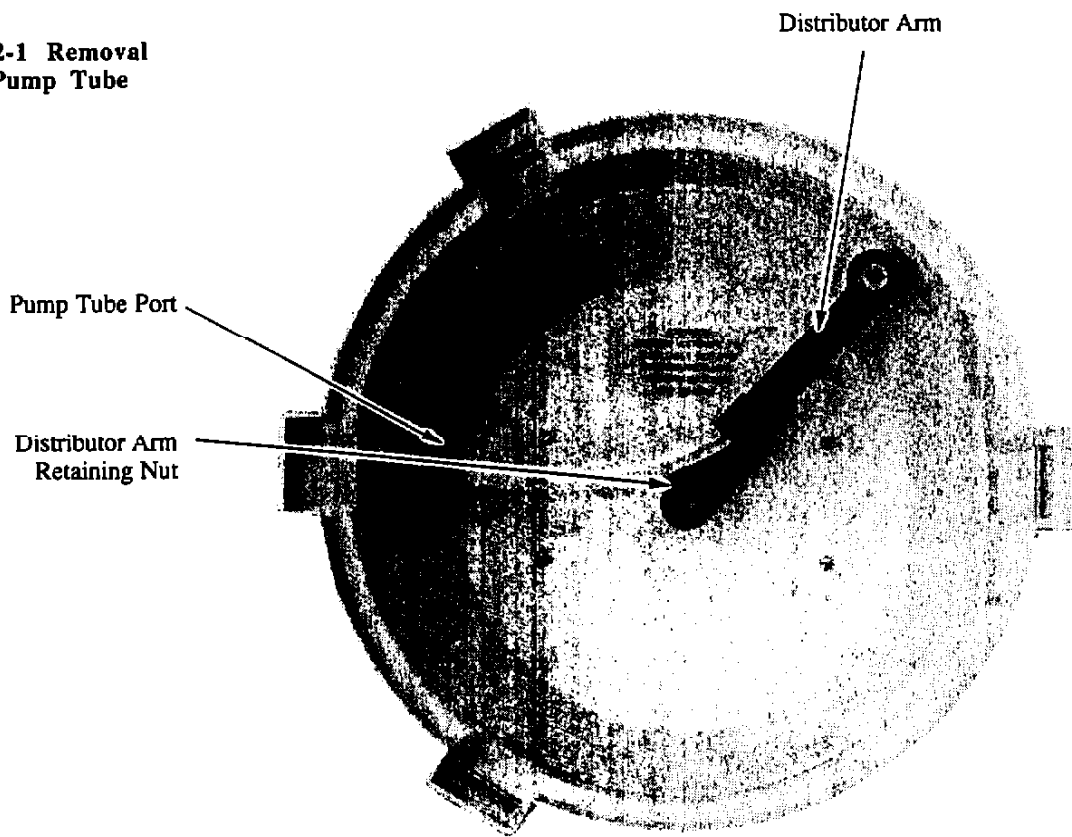
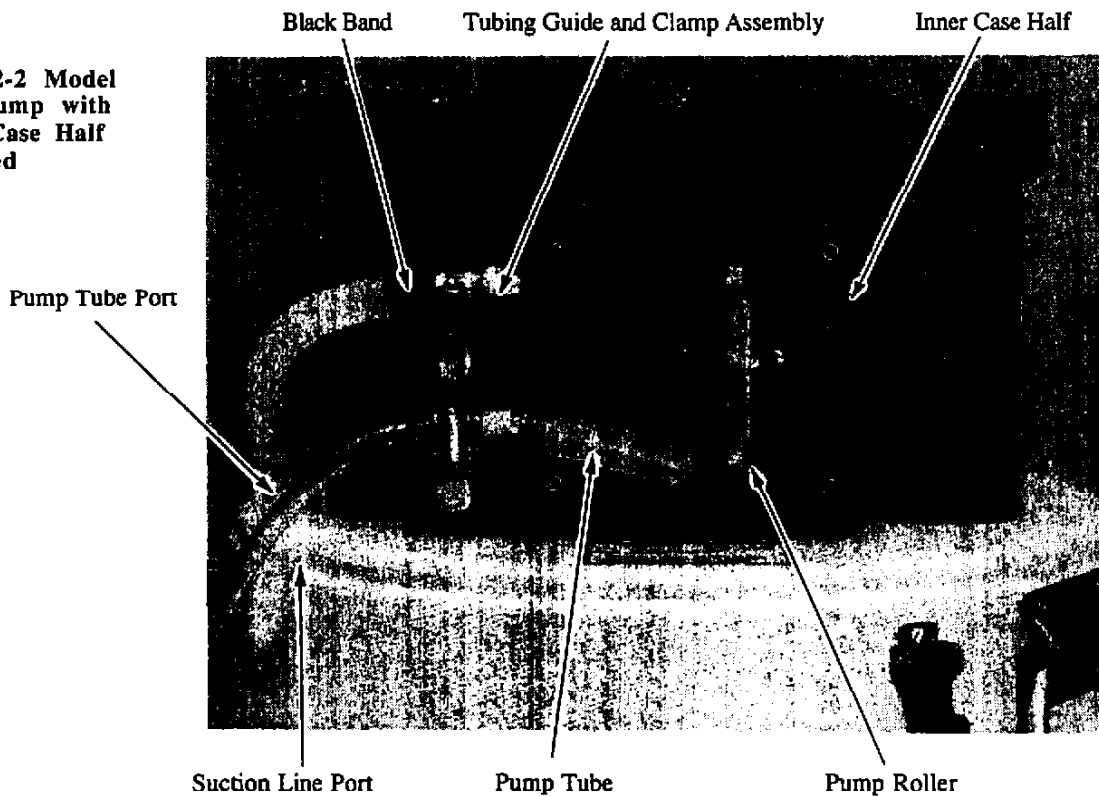

Figure 3.2-2 Model 2900 Pump with Outer Case Half Removed





MODEL 2900

Figure 3.2-3  
Installation of the  
Pump Tube

Feed end of pump tube into distributor arm body.

A

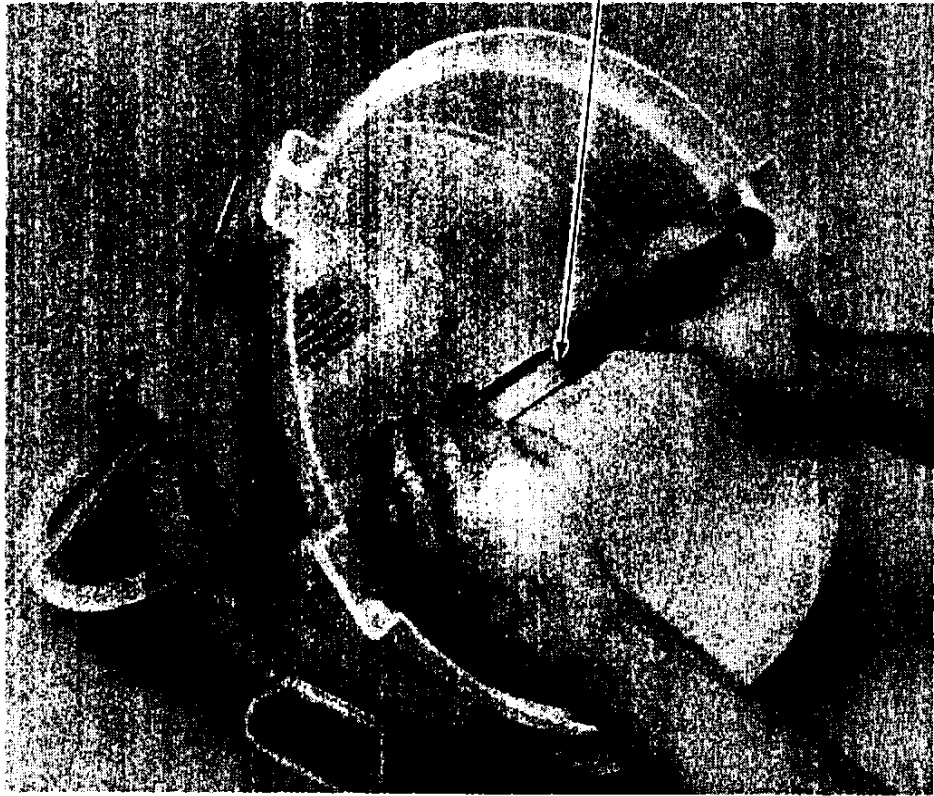

B

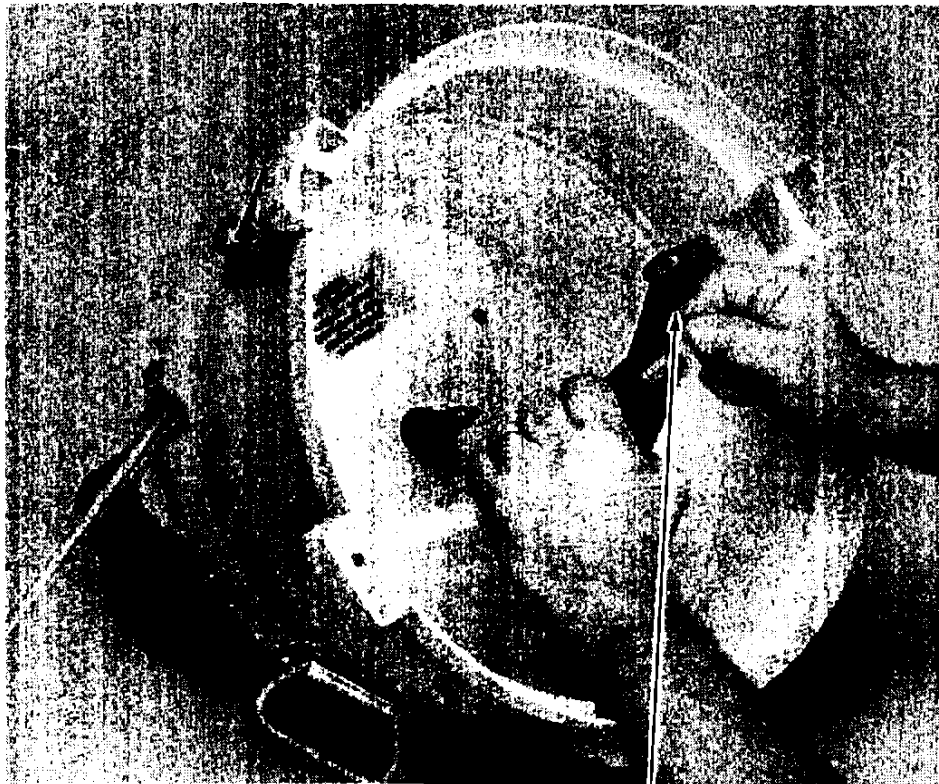

Insert pump tube into outlet of distributor arm.

## MODEL 2900

**3.3 Replacement of Suction Tubing** - It may be desirable to replace the sampler suction tubing for one of several reasons. The suction tubing may have been worn, cut, contaminated, or otherwise damaged. In the case of critical sampling, it may be necessary to replace the suction line between sampling programs, to avoid cross-contamination or it may be necessary to replace the suction line with a line of a different configuration, when changing sampling site conditions.

**Inspection and cleaning of suction line** In any case, it is good practice to periodically inspect the suction line for damage. The suction and the remainder of the pump tubing system should be cleaned occasionally as described in section 3.1.2.

**Replacement vinyl suction lines** Replacement vinyl suction lines are available from Isco in two forms. First, a complete suction line, with weighted strainer, is available in 10 foot and 25 foot lengths for the 1/4 inch and 3/8 inch ID vinyl suction tubes. Second, bulk suction tube in the 1/4 inch ID and 3/8 inch ID vinyl tube is available in 100, 500, and 1000 foot rolls.

**Replacement Teflon line** The 3/8 inch ID Teflon suction tubing is available from Isco in lengths of 10 and 25 feet. If a stainless steel strainer was ordered with the Teflon suction line, it will be attached to the line at the factory.

The following paragraphs discuss the replacement of the complete suction line-strainer assemblies, the sizing of the suction line, and the assembly and installation of the bulk tubing.

**3.3.1 1/4 Inch ID Vinyl Suction Line** - The suction tube is removed from the pump by first removing the outer pump case half by loosening the four captive thumbscrews indicated in Figure 2.1-2. Extract the pump tubing and loosen the pump inlet tubing guide and clamp assembly, and slip it up the pump tube to expose the junction between the suction line and pump tube. Finally, pull the suction line out of the pump tube.

**Complete new suction line** If a complete new suction line-strainer assembly of the standard 10 or 25 foot length is to be used, it is installed as described in section 2.1.4.1.

**Bulk suction line** If it is desired to utilize bulk suction tubing, it will first be necessary to disassemble the old suction line, which was just removed. First, remove the small stainless steel ferrule from within the end of the suction line by slitting the tubing with a sharp knife. The ferrule is necessary to prevent the collapse of the pump and suction tubing when the pump tubing guide and clamp assembly is tightened. Then, remove the strainer and hose clamp from the opposite end of the suction line, as described above. Cut the new suction tube to the desired length, and force the stainless steel ferrule into the end of the suction tube until the ends are flush. Install the strainer on the opposite end of the suction tube and tighten the hose clamp. The new suction line may now be installed in the pump as described in paragraph 2.1.4.1.

**3.3.2 3/8 Inch ID Vinyl Suction Line** - The suction tube is removed from the pump by first removing the outer pump case half by loosening the four captive thumbscrews indicated in Figure 2.1-2. Extract the pump tubing and loosen the pump inlet tubing guide and clamp assembly, and slip it up the pump tube to expose the junction between the suction line and pump tube. Finally, pull the suction line out of the pump tube.

If a complete new suction line-strainer assembly of the standard 10 or 25 foot length is to be used, it is installed as described in section 2.1.5.2.

**Bulk suction line** If it is desired to utilize bulk suction tube in replacing the suction line, it will first be necessary to disassemble the old suction line, which was just removed. First, remove the small stainless steel ferrule from within the end of the suction line by loosening the hose clamp, and slipping the ferrule out of the tube. The ferrule serves as a union between the suction tubing when the pump tubing guide and clamp assembly is tightened. Then, remove the strainer and hose clamp from the opposite end of the suction line, as described above. Cut the new suction tube to the desired length, and force the stainless steel ferrule into the end of the suction tube, until approximately half of it is in the suction tube, and secure it in place with the hose clamp. Install the strainer on the opposite end of the suction tube and tighten the hose clamp. The new suction line may now be installed in the pump as described in section 2.1.4.2.

## MODEL 2900

**3.3.3 3/8 Inch ID Teflon Suction Lines** - The suction tube is removed from the pump by first removing the outer pump case half by loosening the four captive thumbscrews indicated in Figure 2.1-2. Extract the pump tubing and loosen the pump inlet tubing guide and clamp assembly, and slip it up the pump tube to expose the junction between the suction line and pump tube. Finally, pull the suction line out of the pump tube.

**Stainless steel strainer** If a new suction line (either with or without the optional stainless steel strainer) is to be used, it is installed as steel strainer described in section 2.1.4.3. To install the optional stainless steel strainer, carefully slip the strainer's tapered connector inside the suction line and tighten the hose clamp supplied with the strainer, as shown in Figure 3.3-1.

**Figure 3.3-1 Attaching the Stainless Steel Strainer to the Teflon Suction Line**

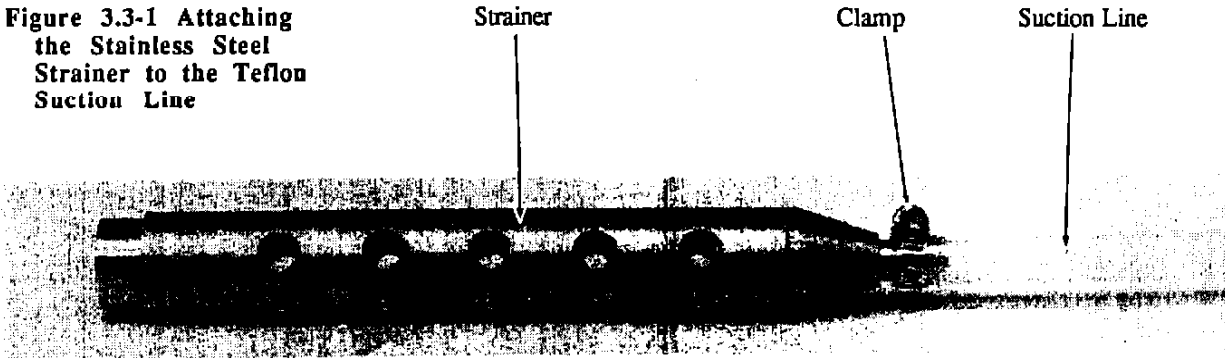

**3.3.4 Conversion for Composite Sampling** - The 2900 Sampler is fully programmable for time-paced and flow-paced composite sampling. To prepare the sampler for composite sampling, the sampler's center section must be converted for composite sampling. This involves removing the distributor arm assembly, installing a shorter pump tube, and installing the composite tube locating strap. The preparation is completed by the addition of a locating ring to the base section.

The steps needed to convert the sampler follow:

1. Separate the center section from the remainder of the sampler, as described in section 2.1.1.
2. Remove the pump tube and distributor arm from the sampler, as described in section 3.2.
3. Turn the center section over and remove two of the screws which attach the control box to the center section. The two screw should be located diagonally across from each other. Refer to Figure 3.3-1.
4. Install the tube locating strap as illustrated in Figure 3.3-1.
5. Feed the 27 inch composite pump tube (supplied with the locating strap and locating ring) through the port in the center section, place it in the locating strap. Next, install the composite tube in the pump as described in section 3.2.
6. Place the locating ring in the bottom of the base section. To seat the ring in the tub, orient the ring as shown in Figure 3.3-3. The locating insert can be used in either the 24 bottle or 12 bottle tub.
7. Place the composite container in the tub and reassemble the sampler.

**Note:** When cooling composite samples with ice, the melt water may cause the bottle to float when the center section is removed.

**MODEL 2900**

**Figure 3.3-2 Installation of Composite Tube Adapter**



**Figure 3.3-3 Placement of the Locating Insert in a 12 Bottle Tub**

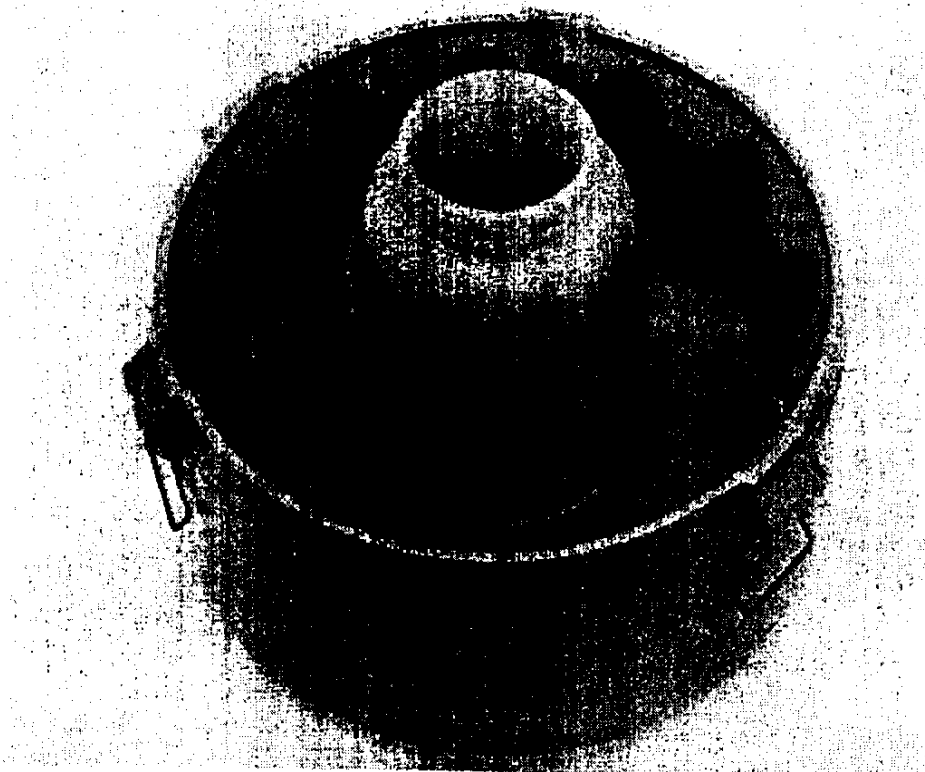

MODEL 2900

**3.4 Changing the Internal Desiccant** - If the humidity indicator described in section 2.2.3.4 indicates the presence of moisture inside the control box, the control box should be inspected to determine if there is a leak, and the desiccant renewed. This is done by unscrewing the ten screws around the outer rim of the control box cover, and carefully lifting the cover off the control box.

---

**CAUTION**

---

*The control box contains electronic circuitry which will be damaged by static discharge. Open the control box only in a static free environment, as described in section 6.4.*

**ALWAYS DISCONNECT THE POWER BEFORE OPENING THE CONTROL BOX.**

---

Inspection of control box

Inspect the inside of the control box for obvious sources of leaks or the presence of collected moisture. If there is a leak, the leak should be repaired by referring to sections 6.5 and 6.7, or returning the control box to the factory. It is strongly recommended that a leaking control box be returned to the factory for analysis, since the factory has specialized equipment to detect leaks and thoroughly test the units after repair.

Renewing desiccant bags

Place a sheet of brown paper on a flat metal sheet. You can use a brown grocery bag and a typical cookie sheet. Place only the bags on the sheet. Do not stack the bags on top of each other or allow them to touch. Place in a vented, circulating forced air, convection oven in a well ventilated room. Allow two inches of air space between the top of the bags and the next metal tray above the bags. Keep the tray a minimum of 16 inches from heating element. Heat the bags at a temperature of 240 to 250°F (116 to 121°C) for 12 to 16 hours. At the end of the time period, the bags should be immediately removed and placed in an air tight container for cooling. The desiccant will be recharged to approximately 80 to 90% of its previous capacity. After repeated recharging, the desiccant bag may require replacement. Replacement bags of desiccant are available from Isco; refer to Table 6.7-1.

Some bags will have the temperature and time for recharging the desiccant printed on the bag. If they differ, use the temperature and time printed on the bag.

The procedure is completed by reinstalling the control box cover. Before reinstalling the cover, coat the cover's gasket with a light film of silicone grease. Tighten the ten screws which hold the control box cover in place using a cross-torquing pattern in even steps.

MODEL 2900

Figure 3.4-1 Control Box Internal Dessicant

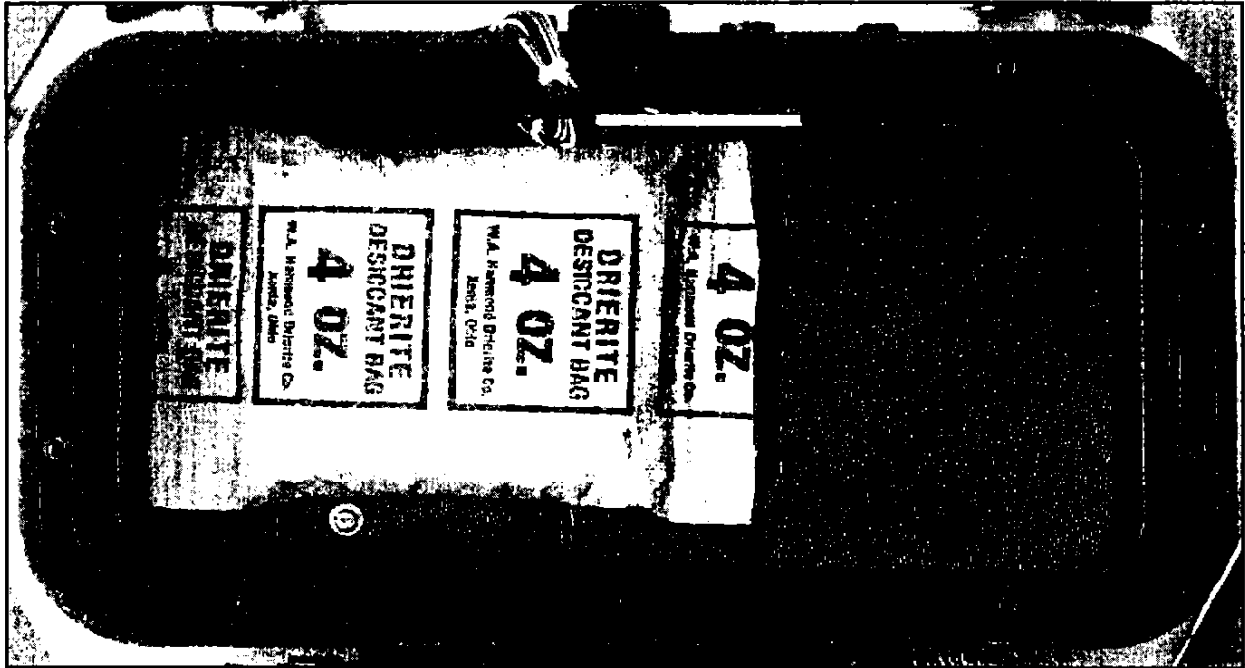

## MODEL 2900

### CHAPTER 4

**4.0 OPTIONS** - This fourth chapter of the Model 2900 Instruction Manual presents information regarding the sampler locking option available for use with the sampler.

**4.1 Sampler Locking** - If it is desired to lock the Model 2900 Sampler to prevent tampering with the controls and sample bottles, an optional sampler locking package is available. The locking package consists of three stainless steel cables and a padlock. To secure the sampler, place the large loop on the end of the cable over one of the latch tabs (with the loop up), and then feed the end of the cable with the small loop up from the bottom through the hole in the latch tab, as shown in Figure 4.1-1,A. Repeat this with the other two cables, and gather the ends of the cables with the small loops at the center of the top cover. Then, feed the padlock through the loops and lock, as shown in Figure 4.1-1,B.

Figure 4.1-1 Locking the Sampler

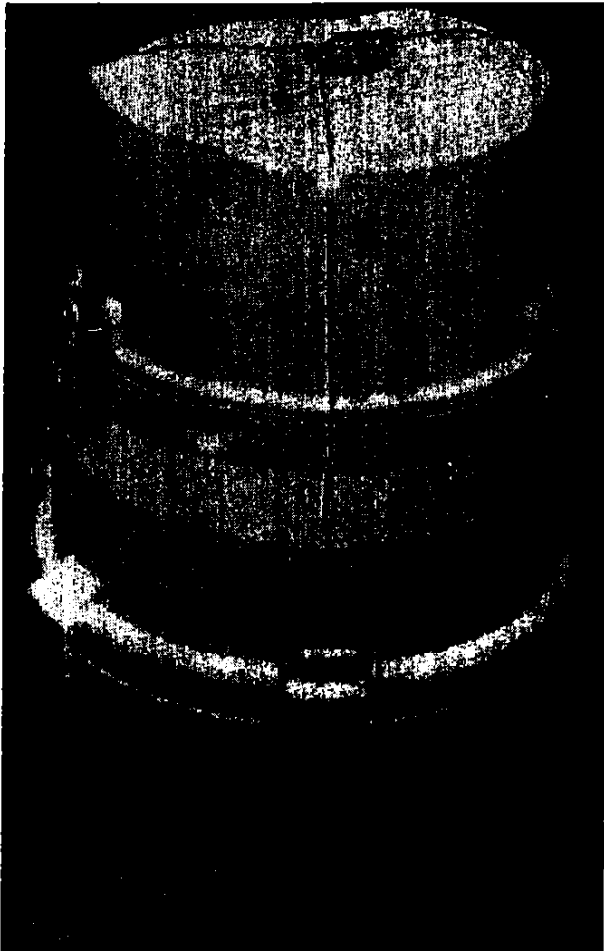

A



B.

**MODEL 2900**



## MODEL 2900

### CHAPTER 5

**5.0 CONSTRUCTION OF THE MODEL 2900 SAMPLER** - This fifth chapter of the Model 2900 Instruction Manual provides a detailed description of certain aspects of the mechanical and electronic construction of the sampler to provide background information which may be necessary for special applications or troubleshooting.

**5.1 Description of Mechanical Construction** - The following paragraphs provide information on the weather and corrosion resistance of the sampler, on the pump and pump drive system of the sampler, and on the liquid distribution system of the sampler.

**5.1.1 Weather and Corrosion Resistance** - The Model 2900 Sampler is designed to be operated in hostile environments such as sanitary sewers without additional protection. However, since a great deal of plastic is utilized in the construction of the sampler, some restrictions regarding the environment must be observed to prevent premature failure of the plastic parts.

**ABS exterior** The tan plastic used in the basic construction of the machine is ABS (acrylonitrile-butadiene-styrene). ABS plastic exhibits good resistance to aqueous solutions containing common acids and bases. Resistance to hydrocarbons, alcohols, vapors from paint thinners such as ketone or aromatic solvents should be suspect however, and placing the sampler in such an environment should be preceded with a test of an ABS sample in the environment.

---

#### NOTE

---

*Isco is not responsible for damage to plastic parts caused by chemical attack.*

---

**Use in sunlight** ABS plastic is resistant to damage from sunlight, but will exhibit some weakening and hardening over a long period of direct sunlight exposure. It is recommended that the outside of the sampler case be sprayed with a good reflective paint, such as aluminum paint, if it is to be continually used in direct sunlight.

**Other materials** All hasps and other case fittings are made of stainless steel or black styrene-butadiene rubber (SBR). All other external components are made of either stainless steel, anodized aluminum, or acetyl plastic.

**Control box** The electronic circuitry, gear trains, drive motors, etc. are housed in a Noryl™ plastic control box. The control box is a completely sealed unit that does not need to be opened during operation. The sampler is programmed and the display read via a label that covers the control box cover. A molded gasket seals the control box cover to the control box bottom section. The contents of the control box are further protected by one 4 oz. bag of moisture-absorbing desiccant installed inside the control box.

**Submersion** Providing that the electrical connectors are either capped or properly attached to their mating connectors which are provided with O-ring seals and that the fuse holder is tightly screwed in place, the sampler will withstand a 6 ft. submersion in water for 30 min. without water leakage into the control box. However, such submersion should be avoided.

**Temperature range** The Model 2900 Sampler can be operated in a temperature range of between 32° F and 120° F. Short exposures to temperatures under 32° F can be tolerated if the suction line does not freeze.

**5.1.2 Pump and Pump Drive System** - Transfer of liquid from the source (flow stream) to the sample bottle is accomplished through the use of the peristaltic pump shown in Figure 3.2-2. Liquid is forced through the pump by the progressive squeezing action of the pump tube by two rollers turning inside the curved surface of the pump case. The tubing used in the pump is a special

## MODEL 2900

grade of silicone tubing 3/8 inch ID, 5/8 inch OD. Features of the peristaltic pump include self-priming, inherent pulsation of the flow stream to help prevent clogging, and a vacuum pulling capacity of 26 feet of water at sea level.

### Pump drive

The pump is driven by a direct current motor, coupled to the pump through a gear train, as shown in Figure 5.1-1. The pump is run in one direction to draw liquid from a source and in the opposite direction to purge the suction line of liquid. At 3 feet of lift, the pump will typically deliver 1500 milliliters of liquid per minute through a 3/8 inch ID suction line. The delivery rate will vary directly with the voltage applied to the sampler. However, volumetric accuracy is not significantly affected by pump speed since the delivery volume is based on an electronic count of the number of revolutions of the pump shaft.

**Figure 5.1-1 Interior View of the Control Box Lower Section**

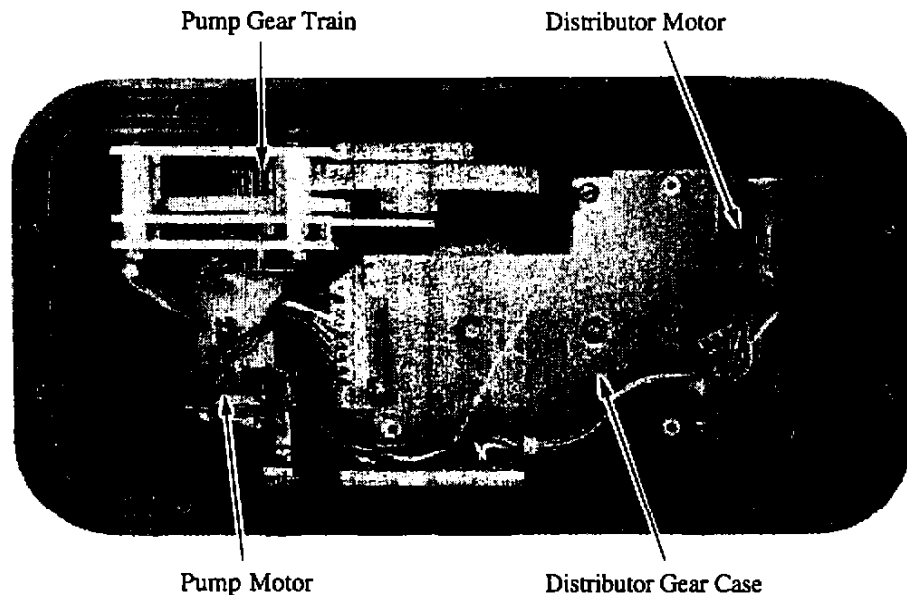

Note: Power PCB has been removed

**5.1.3 Liquid Distribution System** - Liquid is transferred from the source to the pump through either 1/4 or 3/8 inch ID vinyl suction tubing or 3/8 inch ID Teflon suction tubing. The pump outlets to the rotating distributor tube (which is actually a continuation of the pump tube) located directly underneath the pump and control section, as shown in Figure 3.2-1. The liquid is pumped out of the distributor tube directly into the sample bottle. The distributor tube is held in place and rotated by the distributor arm shown in Figure 3.2-1.

### Distributor positioning

The positioning of the distributor is controlled by a Geneva drive mechanism located within the distributor gear case assembly shown in Figure 5.1-1. The mechanism causes the outlet of the distributor to be centered sequentially above each of the 12 or 24 sample bottles. The distributor will rotate counterclockwise, stopping at each bottle location until the last sample bottle location is reached. At this point, sampling will cease. The distributor is reset to the bottle number 1 position by reversing its direction and rotating clockwise to the starting position. A mechanical stop prevents the distributor from directly moving from the last to the 1st bottle filling position. The rotating distributor arm (and distributor shaft) is driven by a direct current motor and multi-stage gear train, also located within the distributor gear case assembly.

---

### CAUTION

---

***Do not attempt to rotate the distributor arm manually, as severe damage may result.***

---

## MODEL 2900

**5.2 Electronic Circuitry** - The following is a general description of the Model 2900 Sampler electronic circuitry. Refer to the main circuit board schematic diagram, Figure 5.2-1, the power supply circuit board schematic diagram, Figure 5.2-2, the case schematic diagram, Figure 5.2-3, and the pictorial views of the circuit boards, Figures 5.2-4 and 5.2-5. Note that in the following description reference will be made to components, such as R3, Q7, IC2, etc. Except as noted, the components will be located on the main circuit board assembly (mounted to the underside of the control box cover). The components located on the power circuit board assembly (mounted on the distributor gear case) will be specifically identified in the text.

The Model 2900 is a microprocessor based instrument. The microprocessor is like a miniature computer that executes a program which is stored in the sampler. The program is a series of commands or instructions that tell the microprocessor what to do in order to accomplish the various functions which the sampler must perform.

The circuitry of the sampler (the "hardware") is discussed in the following paragraphs. However, the program that controls the system (the "software") is discussed only as is necessary to describe the operation of the hardware. A complete discussion of the software is beyond the scope of this manual.

### Power supply

The Model 2900 Sampler utilizes either a 12 volt battery or an Isco 12 volt DC normal speed power pack as its external power source. The external power source enters the Model 2900 through the 12 volt DC connector on the side of the control box. The power source is fused with a 2 amp slow blow fuse. Access to the fuse can be obtained on the side of the control box, as described in section 6.2. Diodes CR1 on the power circuit board and CR1 are isolation diodes, used to isolate the 5 volt regulator from the 12 volt circuitry. Capacitor C2 and diode Z6 on the power board are used to filter high voltage spikes generated by the motors. C1 is used as a voltage filter for the 5 volt regulator source.

The CMOS logic circuitry used in the Model 2900 is powered by a 5 volt supply rail. U1, Q5, R16, R17, R31, R32, and C15, C3 constitute the regulation circuitry for the 5 volt rail. The 5 volt rail is also current regulated. CR6, CR7, and R31 limit the maximum amount of current flow.

One other source of power is a battery contained within the RAM chip. The purpose of this battery is to keep the RAM rail supplied with enough voltage to maintain its memory (data stored in RAM). The battery will not source current until the 5 volt rail drops below a fixed point.

### Clock

The time base for all operations of the Model 2900 Sampler is derived from a 1.2288 MHz crystal. U2, R18, C14, C16 and the crystal form a 1.2288 MHz oscillator. The zero output (pin 9) of U2 will clock the CPU (U5) with a 1.2288 MHz clock signal. Inside U5 is a divide-by-eight counter which produces a 153.6 HZ frequency that appears at TPA, pin 34 and TPB, pin 33.

U2 also generates a 37.5 HZ clock signal (Q14, pin 3) which clocks U3, whose output forms the interrupt signal supplied to pin 36 of U5. All the registers are up-dated and flags serviced during each interrupt cycle.

The U3 output signal also clocks U3 reset, causing the removal of the wait signal on pin 2 of the CPU chip. After the servicing of the interrupt, U5 will output a high on pin 5 and pin 4. The output from pin 5 will reset U3, setting the stage for the next interrupt signal. The output from pin 4 will clock U3, causing the CPU to go into its wait mode of operation.

### Central processing unit

The central processing unit is a CDP1802 CMOS unit selected for its low current consumption. This unit controls the various data transfers that occur on its 8-bit data bus. It communicates with associated circuitry by sending or receiving 8-bit "bytes" from the data bus, sensing high or low levels on its external flag (EF) lines, or its interrupt input. It controls data transfers through its memory address lines, its "N" lines, the memory read line (MRD), and the memory write line (MWR).

## MODEL 2900

- Memory select/latch** The memory select and latch circuit consists of U7 and U17. These chips are required since the CPU issues its 16-bit memory address in two consecutive 8-bit bytes on the memory address lines, pins 25-32. When TPA occurs, U7 latches the 8 bits of the high order byte. U7 will then generate address lines A8 through A15. The address line A15 is used to select either U10 (PROM) or U13 (RAM). MA0 through MA12 are used to address specific locations within these chips. Memory address line 15 is utilized as both a chip select (CS) and a chip enable (CE) signal. The three IC chips concerned with the memory addressing are U5 (CPU), U13 (RAM), and U10 (ROM).
- ROM** The read only memory (ROM) contains the list of steps (the program) which the CPU is to execute. U10 is an erasable programmable read only memory chip. This IC's program can be erased by exposing it to ultraviolet light. The content of the ROM is non-volatile; that is, it does not change if power is removed or lost.
- When a particular byte is to be read, the sequence of events begins with the presentation of the high order memory address byte at the memory address lines of the CPU. When TPA goes high, U7 latches the memory address byte. The CPU then issues the low order byte (MA0 through MA7) of the memory address to be read. The low order bits (MA0 through MA12) will determine the particular byte to be read within the ROM or RAM. Then, if MA15 is low, the PROM will be selected or if MA15 is high, the RAM will be selected through U17. When the CPU issues the memory read signal (MRD), the selected byte of data will be placed on the data bus where it will be received by the CPU and perhaps by one of the auxiliary circuits connected to the data bus.
- RAM** The random access memory (RAM) is a temporary data storage area. The RAM used by the Model 2900, U13, contains 2048 bytes, each byte consisting of 8 bits. The RAM, unlike the ROM, can be written into. The RAM is accessed in the same manner as the ROM.
- If the RAM is selected by the memory latch and select circuit (U7 and U17), it will present the contents of the addressed cell to the data bus when the MRD line goes low (pin 20), or it will write the byte presented on the data bus into the addressed cell when the MWR line goes low (pin 21).
- The data contained in the RAM would ordinarily be retained only as long as power is present. In order not to lose data stored in the RAM, the RAM used in the Model 2900 contains an internal battery. (This battery is explained in the power supply circuit description.)
- Start up circuitry** When power is first applied to the Model 2900, the circuitry microprocessor and all the input/output ports must be reset. In order to accomplish this, U12, U6, R56, R57, R58, and C25 are used. U12 is used as a voltage detector. When the 5 volt rail reaches 5 volts, determined by the voltage divider R56 and R57, the output (pin 4) of U12 will go high. This output then passes through two inverters (U6). This allows the 5 volt rail to stabilize before the clear line goes high and allows the CPU to start.
- Front panel keypad** The Model 2900 keypad utilizes a 6 row, 4 column touch keypad for all manual switching needs. The keypad operates on an "XY" axis system. U4, U16, U8, and U18 combine with the keypad (P1) to form the circuitry needed to read which key is being depressed. U16 is a decoder chip that has two inputs and four outputs. The purpose of U16 is to apply a ground potential on one of the columns at a specific time. The output that goes low is determined by the inputs to the IC. The inputs are derived from the output device U18. U18 receives its information from the data bus lines. To determine which switch is being depressed, U4, an input device, will read the rows of the keypad.
- The program constantly strobos the keypad to determine if any switches are being depressed. This is accomplished by U18 first taking the information from the data bus lines and applying two bits to the inputs of U16. U16 then decodes these two bits and one of its four outputs will go low. This will place a ground potential on one of the four columns of the keypad. Next, U4 will be selected and read to determine if any of its inputs are low. The CPU can determine which switch has been depressed by knowing which column it placed low and which U4 input went low.

## MODEL 2900

- LCD display** The LCD display circuit consists of U16, U18 through U23, and the LCD component. U22 is a four-digit CMOS display decoder and driver device. The information that will be decoded comes in on the data bus. After this information is decoded, U22 will output signals to the LCD component to drive specific segments of each digit.
- U18 through U21 and U23 compile the circuitry that drives the individual legends located within the LCD component. The information that determines which legend is to be selected is passed to U18 and U19 via the data bus lines. U18 and U19 will then interpret this information and select the correct legend. This select signal will be passed through an exclusive-or gate prior to being applied to the LCD component.
- Low voltage detect** The low voltage detect circuit consists of U11, U6, R53, R54, R55, and C24. This circuit monitors the 12 volt source and will enable the unit to go into a non-active (idle) state of operation when the source voltage is lower than approximately 9.2 volts. When the source voltage for the voltage divider R53 and R54 reaches approximately 9.2 volts, the output of U11 will go low. This low will cause a high signal on the output of the inverter U6. This high signal is then passed to the CPU and sets the interrupt to the CPU. The CPU will then go into an idle state until the source voltage is brought back above 9.2 volts.
- Distributor motor control** The distributor motor driver circuitry is located on the power board. Transistors Q3, Q5, Q10, Q11, Q12, and Q13 (on the power board) along with associated resistors drive the distributor motor in response to logic signals from U9 on the main circuit board. When the distributor is to advance, U9 - pin 9 (on the main board) goes high. This turns on transistors Q3, Q10, and Q13. When the distributor is reset, U9 - pin 10 (on the main board) goes high. This turns on transistors Q5, Q11, and Q12, causing the distributor motor to rotate in the reverse direction.
- Distributor position sensor** U9, U4, Q6, R37, R38, R41, R48, C18, and the interrupt module comprise the distributor position sensor circuitry. When output Q7 (pin 1) of U9 goes high, Q6 is biased (turned on), thus supplying a ground to the interrupt module's LED. This ground allows the LED to turn on, which in turn biases the interrupt module's photo transistor when the interrupt flag is not blocking the LED's light path. When the photo transistor is turned on, a 5 volt signal is applied to pin 16 (DI4) of U4. This 5 volt signal indicates that the distributor is not over a bottle.
- Pump motor control** The circuitry that controls the pump motor is also located on the power circuit board. Transistors Q1, Q2, and Q6 to Q9 along with associated resistors are used to apply power to the pump motor when required. When the pump is to run in the forward direction, the CPU causes an output instruction to occur that sets pin 11 of U9 on the main circuit board to a high (+5 volt) level. This turns on Q1 on the power board which in turn biases Q6 and Q9. Q6 and Q9 then apply power to the pump motor. When the pump is to run in the reverse direction, pin 12 of U9 is set to a high level, turning Q2, Q7, and Q8 on. This applies power to the motor in the reverse polarity.
- Pump volume count sensor** The pump interrupt module, U6, R39, R40, and C20 combine to form the pump volume count sensor circuitry. The pump interrupt module is an LED-photo transistor device. When the pump's volume disk rotates between the photo transistor and LED, a pulse is generated. This pulse passes through an inverter prior to going to the CPU. The CPU counts each pulse to determine the amount of volume that is being pumped. R40 and C20 form a timing constant to eliminate noise.
- Flow pulse** Flow pulse inputs from an external flow meter enter the sampler on pin C of the flow meter connector. They then pass through a wiring harness to P2, pin 12. R34 and Z1 maintain the flow pulse input level to U6 at 6.8 volts. R35 and C17 form a timing constant to eliminate any noise. U6 inverts the flow pulses and also forms a buffer between the input and U4. U4 is an input device which will place the flow pulse on the data bus so that this information can be retrieved by the CPU.

## MODEL 2900

Event mark connector	The event mark signal present at pin E of the flow meter occurs during the beginning of a prepurge portion of a sampling cycle. It is a 12 volt DC signal, capable of driving a 2 amp load. The circuit consists of U9, Q2, Q3, Q4, R12, R13, R14, R15, and R33. At the beginning of a pump cycle, U9 will output a high signal from Q4 (pin 13). This high will bias Q2 on. Q2 in turn will bias Q3 on, which in turn biases Q4 on. When Q4 turns on, 12 volts will be applied to pin E of the flow meter connector.
Inhibit	If a Model 1640 Liquid Level Sampler Actuator is being used with the Model 2900, the inhibit signal enters the sampler through pin F of the flow meter connector. Pin F is normally pulled high by R46. When the inhibit signal is present, the high is pulled low. The low is inverted by U6. The resulting high is then passed to U5, which is the CPU device. The CPU notes the flag change and halts all sampling processes.
Bottle number	The bottle number circuitry generates a series of pulse signals that represent the bottle number that the Model 2900 distributor arm is on. These pulses are sent out through pin D of the flow meter connector. U9 will receive the information from the data bus and pass this information out Q5 (pin 14). This signal will bias Q7, which then biases Q8, placing a 5 volt pulsed signal on pin D of the connector.
Beeper	U18, Q1, DS1, and R1 combine to form the beeper circuitry. When U18 outputs a 5 volt DC signal (Q0, pin 9) Q1 is biased. A biased Q1 places a ground on DS1 (beeper), which in turn allows 12 volts DC to be dropped across the beeper, causing an audio tone.

# MODEL 2900

Figure 5.2-2 Power Supply Circuit Board Schematic Diagram

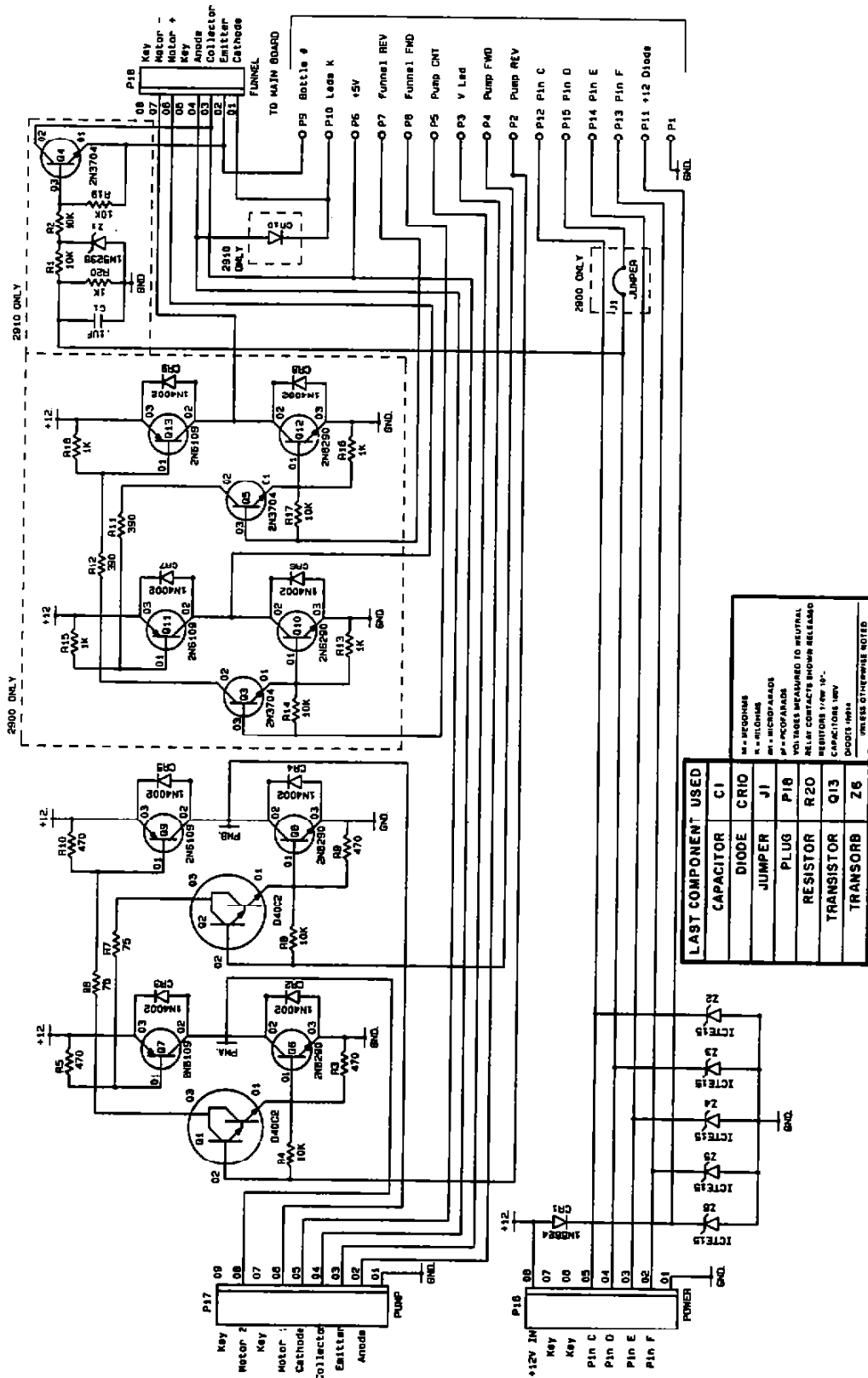

MODEL 2900

Figure 5.2-3 Case Schematic Diagram

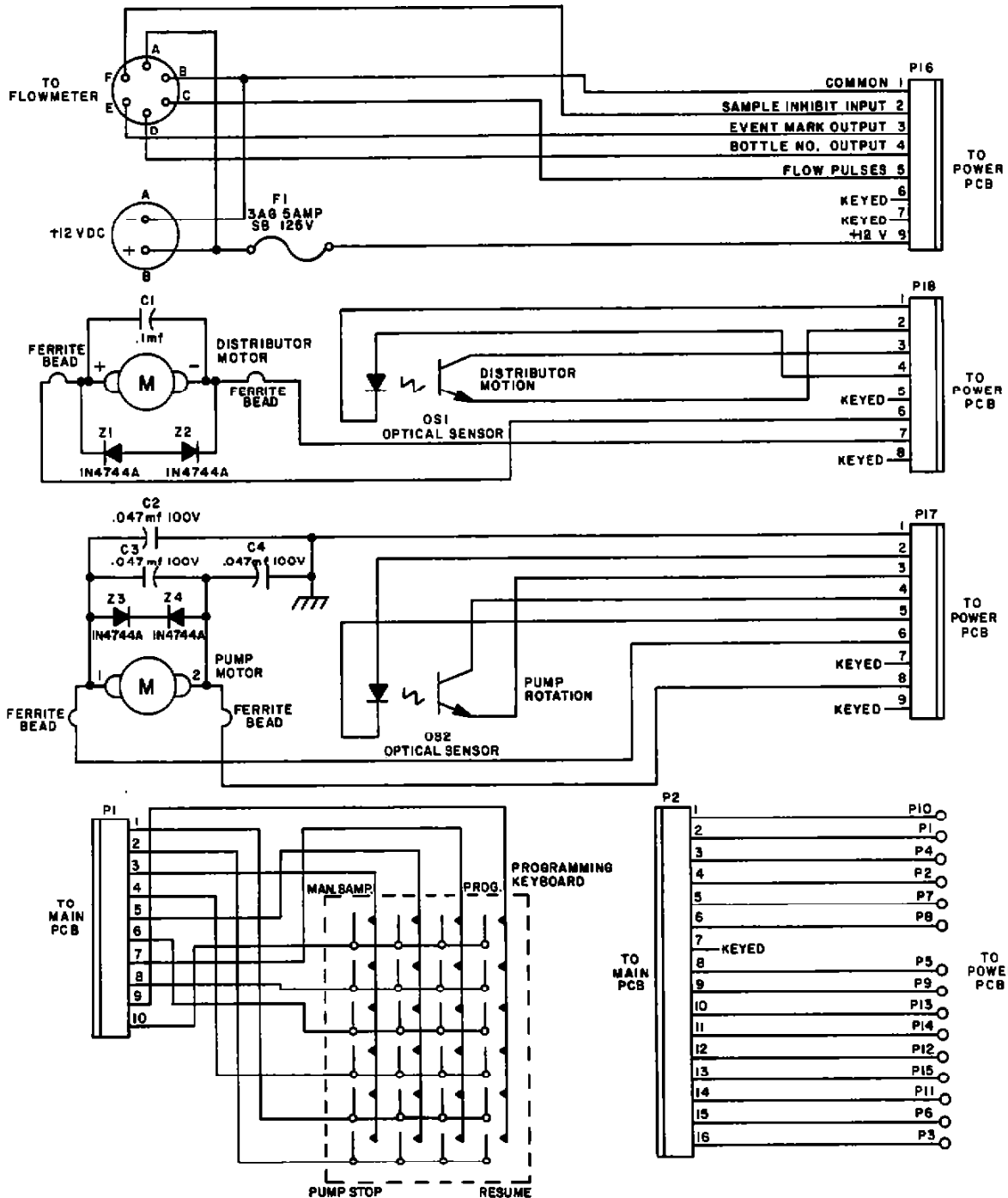

M = MEGOHMS  
 K = KILOHMS  
 mF = MICROFARADS  
 pF = PICOFARADS  
 VOLTAGES MEASURED TO NEUTRAL  
 RELAY CONTACTS SHOWN RELEASED  
 RESISTORS 1/4W 10%  
 CAPACITORS 100V  
 DIODES IN914  
 UNLESS OTHERWISE NOTED



**MODEL 2900**

**Figure 5.2-4 Main Circuit Board Assembly**

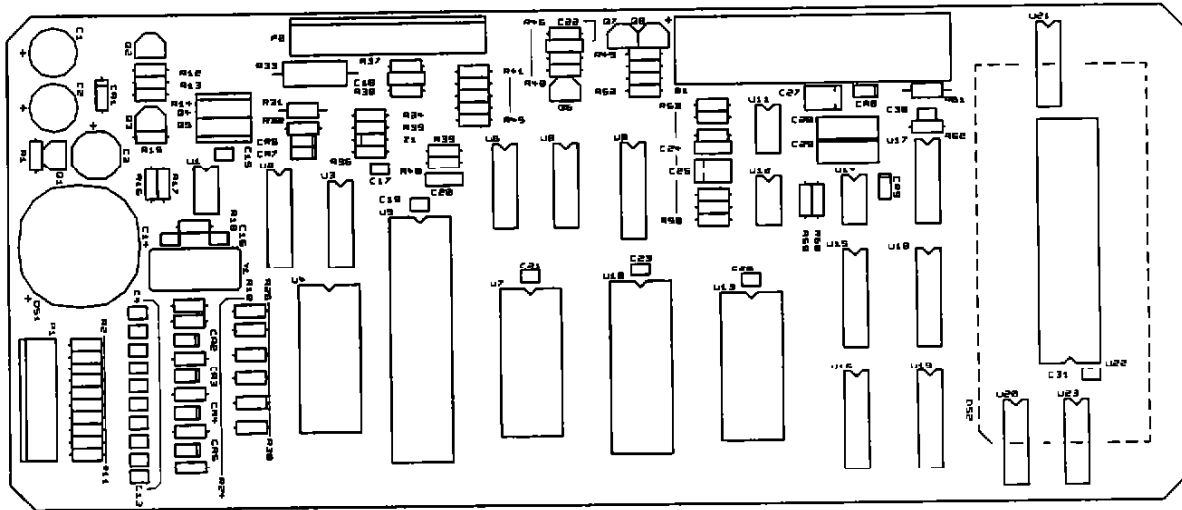

**Figure 5.2-5 Power Supply Circuit Board Assembly**

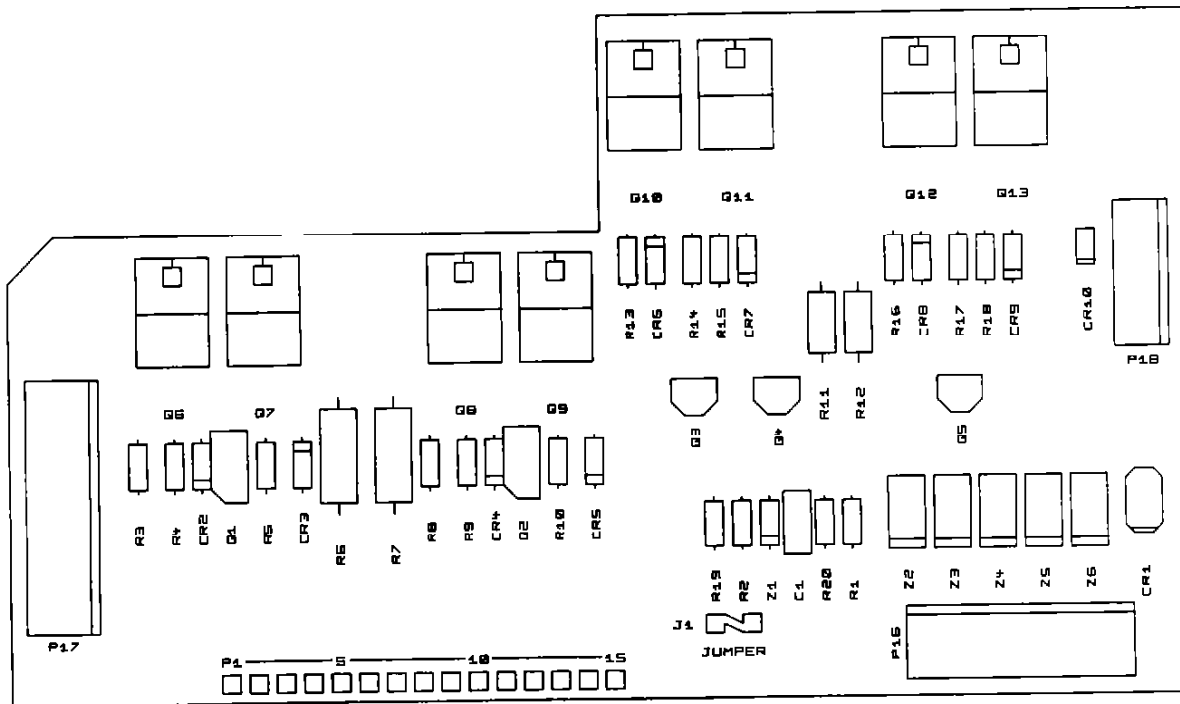

## MODEL 2900

### CHAPTER 6

**6.0 SERVICING AND TROUBLESHOOTING** - The sixth chapter of the Model 2900 Instruction Manual presents sampler servicing information and a trouble shooting guide to assist the user in correcting any malfunctions which might occur. Included are paragraphs providing information on the replacement of the external fuse, on the removal of the control box, on the care of CMOS circuitry in general, on gaining access to the electronic components, and on the description of the sampler's self-diagnostics. Also included is a troubleshooting section and illustrated replacement parts list.

**Background for servicing** Before attempting to service or repair the sampler, it is strongly suggested that Chapter 5 of this instruction manual covering the construction of the sampler be thoroughly read and understood. Should any service related questions arise, feel free to consult with our Customer Service Department at the location listed in the preface to this instruction manual.

**6.1 Replacement of the Fuse** - The Model 2900 Sampler is protected by a 2 amp "slow blow" fuse, located on the side of the control box near the connectors, as shown in Figure 2.1-5. Should the fuse blow, it may be replaced by unscrewing the fuse holder cover, removing the blown fuse, inserting a new fuse in the holder, and reinstalling the holder cover. To maintain watertightness of the control box, be sure the fuse holder is tightly screwed in place. Should the fuse repeatedly blow, it probably indicates a problem in the electronic circuitry.

**6.2 Removal of the Control Box** - Should there be a problem with the sampler which requires factory service, it is usually easiest to return only the control box for repair. The control box is removed from the sampler in the following manner. First, separate the center section from the sampler following the procedure described in section 2.1.1 and disconnect the power source from the control box. Remove the suction tube from the pump, and turn the center section over, as shown in Figure 6.2-1.

Unscrew the distributor arm retaining nut, indicated in Figure 6.2-1, and pull the arm off the distributor shaft. Pull the pump tube out of the distributor arm, and feed it out of the pump tube port in the center section. The control box may then be removed by unscrewing the four screws indicated in Figure 6.2-1, and lifting the center section plastic off the control box. Screw the four screws and their lock washers into the control box to prevent losing them.

**Packing for return** When returning the control box to the factory for repair, be sure to pack it securely, protecting the distributor shaft, and include a note explaining the problem.

**MODEL 2900**

**Figure 6.2-1 Removing the Control Box**

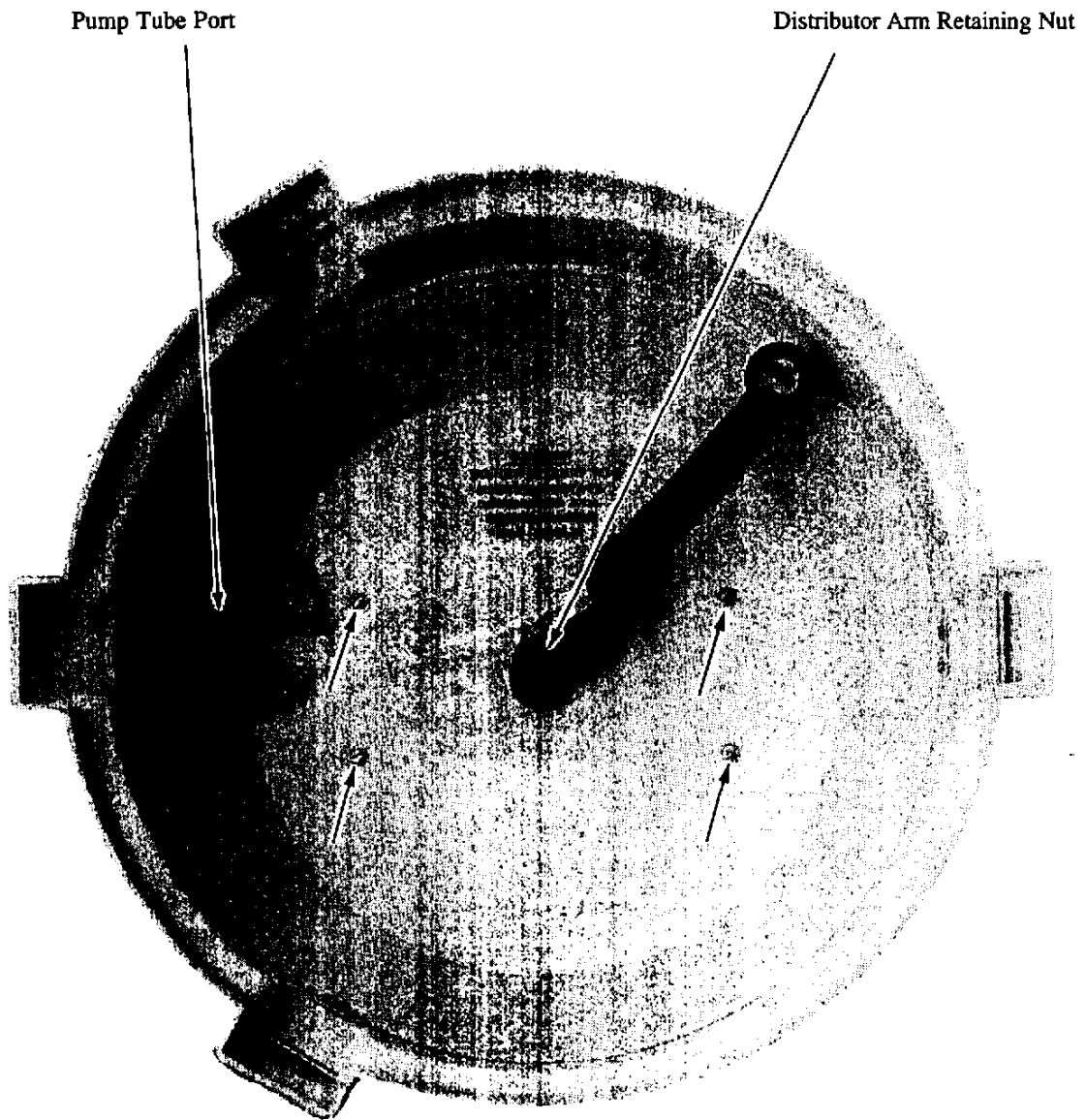

**Remove the Control Box by Unscrewing Four Screws**

## MODEL 2900

**6.3 Hints on Troubleshooting and Repair of CMOS Circuitry** - Most of the Model 2900 Sampler circuitry consists of complimentary CMOS components. Because of the extremely high input impedance of CMOS integrated circuits, certain precautions must be taken when working on such circuitry.

### Protection from

The voltage levels present from static build-up due to walking static discharge over carpeted floors, movement of woolen or synthetic clothes over chair seats, workbenches, etc., are sufficiently high to destroy CMOS circuitry when performing repair work. Ideally, all tools, soldering irons, etc., should be conducted to a grounded metal work bench, with grounding straps applied to the wrists of personnel. It is recognized that in most field repair situations, such precautions are impractical. However, certain extreme hazards must be avoided.

1. Never remove the control panel or perform any electronic work in a room with a carpeted floor.
2. Always roll up work clothes sleeves so that your bare arms are in contact with the working surface.
3. Avoid using a work surface made of an extremely good insulator such as "Formica" or glass. Metal is best; a wood surface would be next best.
4. The degree of hazard will usually depend upon the level of humidity. Be particularly careful if the work place is extremely dry.
5. When arriving at the workplace, after the unit has been opened for repair, always make an effort to touch the metal chassis with at least one hand before touching any of the circuit conductors.
6. Be especially careful of the CMOS integrated circuits when they are removed from the rest of the circuitry. Simply being connected to the rest of the circuitry will, in most cases, provide some protection. Most of the circuitry is quite well protected from such damage when a battery or power pack is connected. However, never remove or replace an IC while the circuit is under power.

**6.4 Access to Electronic and Other Internal Components** - All of the electronic components of the Model 2900 Sampler are mounted within the control box. The basic circuitry of the sampler is contained on a single circuit board assembly which is mounted to the underside of the control box cover.

### Observe static precautions

As discussed in section 6.6, below, Isco believes that the Model 2900 is most efficiently serviced by returning it to the factory. However, should the user choose to service the unit, the electronic components may be accessed as follows. When handling the internal components, be sure to observe precaution regarding CMOS circuitry described in section 6.3.

To gain access to the electronic components, first disconnect the power source from the sampler. Then, remove the ten screws around the outer edge of the control box cover. Lift the cover off the control box's base, and turn it over, as shown in Figure 6.4-1. The control box cover assembly may be disconnected from the control box lower section by disconnecting the connector indicated in Figure 6.4-2. The main circuit board assembly of the Model 2900 is protected by an aluminum shield. To remove this shield, unscrew the four screws indicated in Figure 6.4-1, and lift the shield off. This will reveal the main circuit board, as shown in Figure 6.4-2. To remove the circuit board assembly from the control box cover, unscrew the four hex threaded standoffs, indicated in Figure 6.4-2. The circuit board may now be pulled away from the control box cover. To completely disconnect the circuit board assembly from the cover, disconnect the connector shown in Figure 6.4-2.

MODEL 2900

Figure 6.4-1 View of the Underside of the Control Box Cover

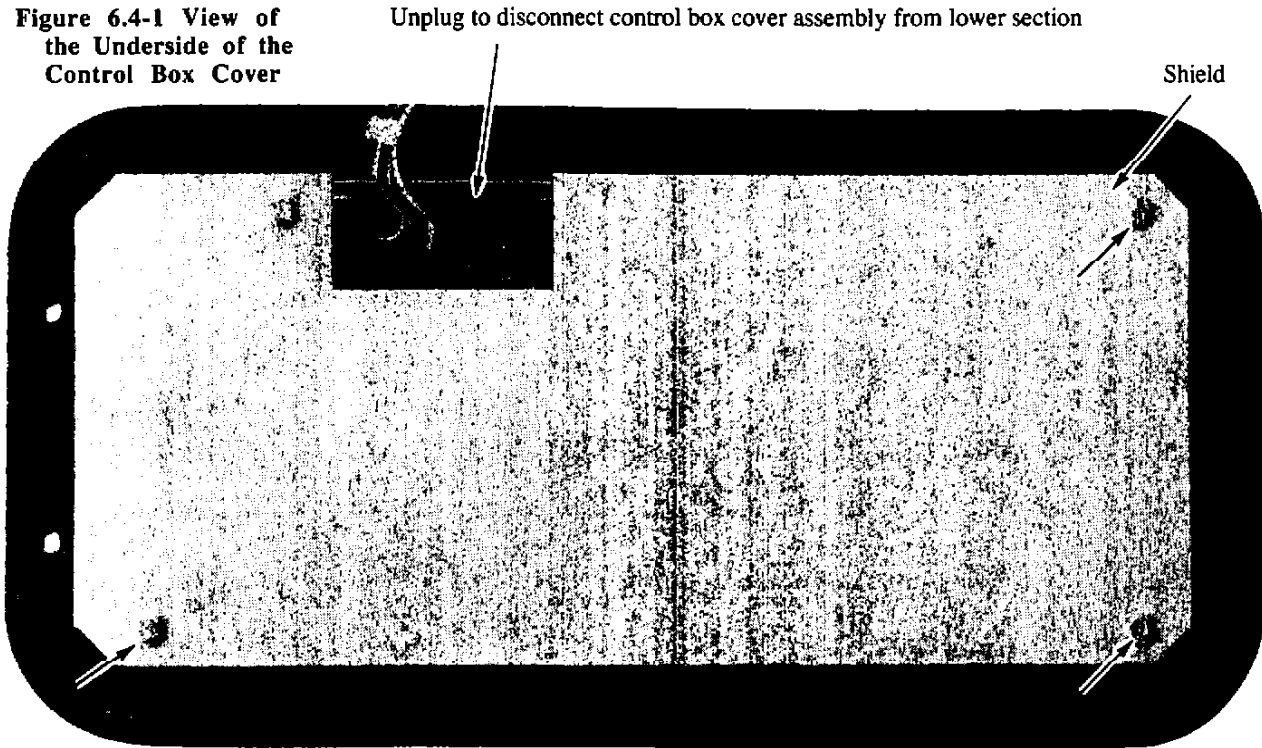
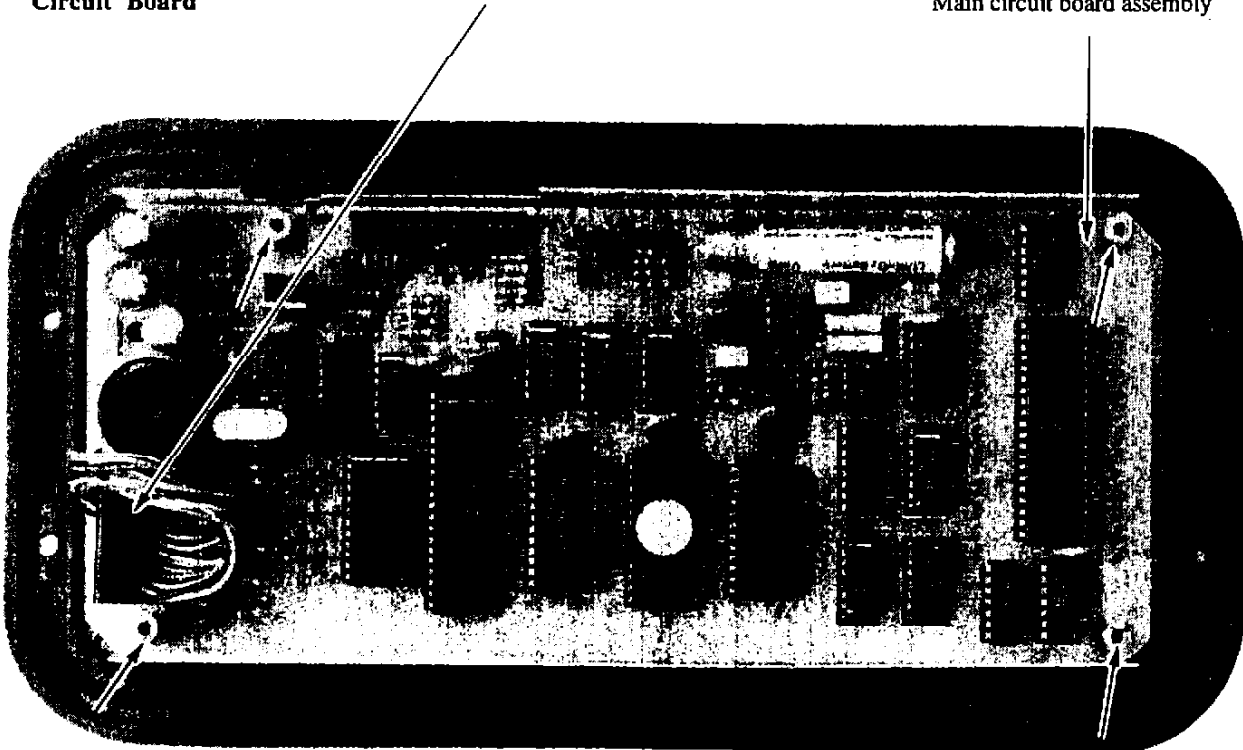

Figure 6.4-2 Main Circuit Board

Unplug to disconnect circuit board from cover.

Main circuit board assembly



Unscrew to remove circuit board

MODEL 2900

Figure 6.4-3 Control Box Tray Removal

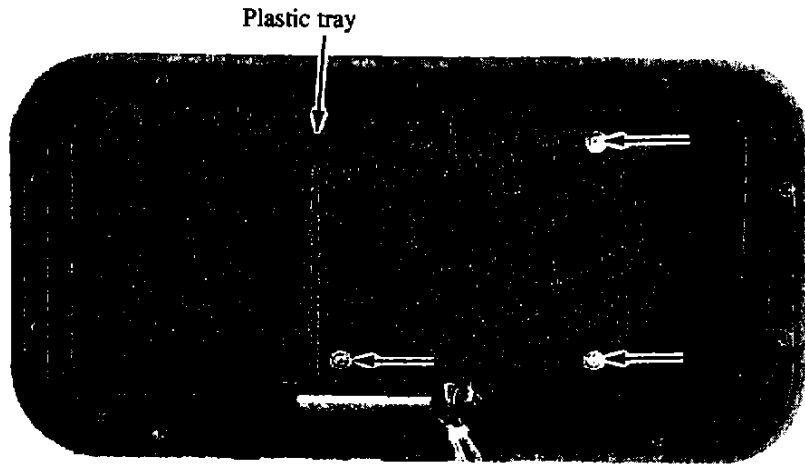

Unscrew to remove tray.

Figure 6.4-4 Power Circuit Board Removal

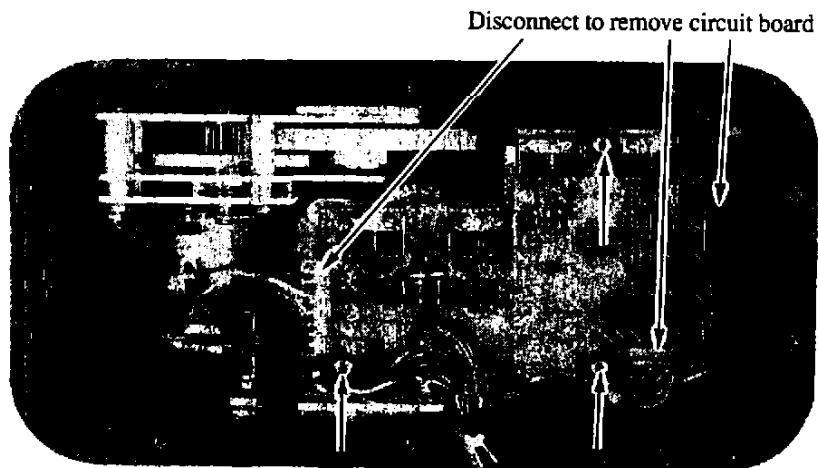

Unscrew to remove circuit board

Figure 6.4-5 Distributor Gear Case Removal

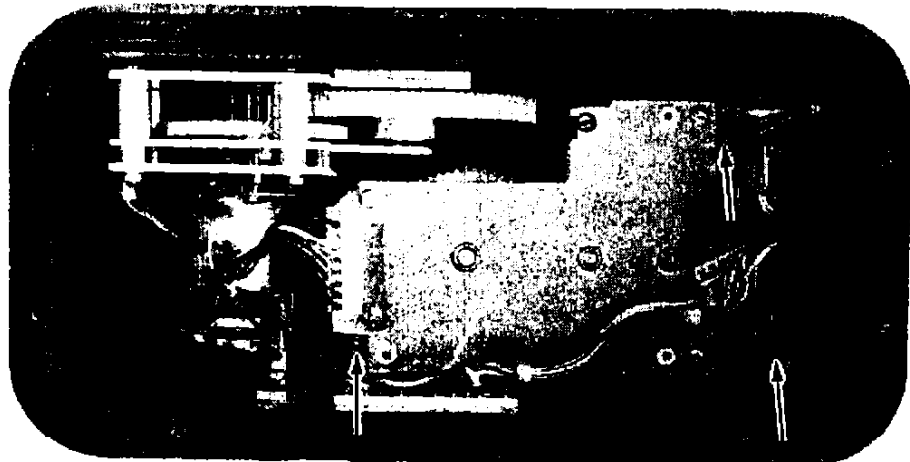

Unscrew to remove distributor gear case

## MODEL 2900

### Access to distributor and pump

The distributor and pump gear case assemblies are located in the lower section of the control box. To gain access to these and other components in the control box lower section, remove the three screws indicated in Figure 6.4-3. Then lift the plastic tray straight up out of the control box. The distributor gear case may be removed from the control box by disconnecting the three electrical connectors and unscrewing the three hex threaded standoffs from the power circuit board, indicated in Figure 6.4-4. The power circuit board may now be removed, which will then allow access to the three screws securing the distributor gear case to the cabinet bottom. Unscrew the three screws indicated in Figure 6.4-5, and lift the distributor gear case straight out of the control box. The pump gear case may then be removed by removing the pump's outer case and unscrewing the four screws on the pump's inner case.

**6.5 Self-Diagnostics** - The Model 2900 is programmed to run self-diagnostic routines to check out certain key circuit components and other aspects of its operation. Three different self-diagnostic routines are or may be run: power up diagnostics, diagnostics during normal operation, and manually initiated diagnostics. These are discussed individually in the following sections. The sampler's error messages are summarized in Table 2.2-1.

**6.5.1 Power Up** - Upon power up, the sampler runs diagnostic routines on its PROM (programmable read only memory) and RAM (random access memory). The PROM, which stores the sampler's operating program, has its checksum verified. The RAM, which is used for temporary storage, is subjected to a pattern check. Power up is defined as a condition where external power (either a battery or power pack) has been removed from the sampler for a period of time long enough for the capacitors to discharge (approximately 10 seconds), and is then reconnected.

### Operation of display

Upon power up, the sampler's display will show "PPPP," indicating that the PROM checks are being made. If the PROM check is successful, the display will show "EEEE," indicating that the RAM checks are being made. If the RAM check is successful, the display will be cleared indicating the end of the power up diagnostics. If the sampler fails either portion of the diagnostic checks, the display will "stick" on either "PPPP" or "EEEE," depending upon which failed. The display can be cleared only by powering the unit down and back up. However, this will cause the power up diagnostics to be run again, and the probability is high that the sampler will fail the diagnostics at the same point again. After the diagnostics have been run, if the sampler had been on when power was removed, the distributor will run to its "home" position (a stop just before the bottle 1 position) to verify registration, and then return to its previous position. If the sampler had been off when power was removed, the distributor arm will run to its home position the first time it is turned on after a power up.

**6.5.1 Normal Operation** - When the sampler is in the off, standby, and run states, a PROM checksum and RAM pattern check (similar to the power up diagnostic checks) are run approximately every 30 seconds. Thus, during the majority of the sampler's normal operation, the PROM and RAM are checked on a regular, frequent basis.

As long as the PROM and RAM checks are successful, the user will not even be aware that the checks are being run. However, should the sampler fail one of the checks, an error condition will be indicated on the display. If the sampler is operating in the off or standby states when an error is detected, the display will rotate between two EEs ("EE-") and either a 1 (" 1") or a 2 (" 2"). The 1 indicates a failure to pass the PROM check, while a 2 indicates a failure to pass the RAM check. If the sampler is operating in the run mode, two EE's ("EE-") will replace time or flow pulse interval to the next sample in the normal rotation of the display. There will be no indication as to whether the error occurred during a PROM or RAM check. However, if a sampler with an error detected while in the run state is subsequently transferred from the run to the off or standby state, the display will alternate between two EEs ("EE-") and either a 1 (" 1") or a 2 (" 2").

## MODEL 2900

**Clearing error message** The error message may be cleared from the display only by powering the unit down and back up. However, this will cause the power up diagnostics to be run, and there is a good chance that a PROM or RAM error will again be detected. The exception to this is if the error were originally caused by transitory electronic malfunction ("glitch") and not a hard error.

**6.5.2 Manually Initiated** - A more extensive diagnostic routine may also be manually initiated when desired. For a sampler in the standby state, pressing the PUMP STOP key five times in succession will cause the manually initiated diagnostic routine to be run. The manually initiated diagnostic routine is composed of two portions. The first portion runs automatically. The second portion consists of a number of individual tests which may be run at the operator's option.

**Automatic portion** The automatic portion of the manually initiated diagnostics begins shortly after the PUMP STOP key is pressed five times. First, the nine legends are individually turned on in order (TIME, FLOW, COMP, BTL #, MPLX, PRGM, STEP, STNDBY, LOCK, and RUN). Then, the following series of patterns are shown on the display:

"0000"  
"1111"  
"2222"  
"3333"  
"4444"  
"5555"  
"6666"  
"7777"  
"8888"  
"9999"  
"1234"  
"2468"  
"3579"  
" \_ "  
"FULL"  
"HELP"

The display is then cleared, and the pump is turned on in the forward direction for approximately 2 seconds. After the pump shuts off, the display will alternate between two numbers. These numbers are used at the factory to check the optical system that counts revolutions of the pump. The smaller of these two numbers should be at least 100, and the larger should be less than twice the smaller number. If the optical system is inoperative, an error message will be shown on the display: a rotation between two EEs ("-EE-") and a G (" G"), indicating faulty pump rotation counting optics.

**Individual procedures** This completes the automatic portion of the manually initiated diagnostics. At this point, the user may choose to end the diagnostics, or may choose to run one or more of several individual diagnostic procedures. These procedures are started by pressing the keys listed below. When the procedure is ended, the display will return to the rotation between the two numbers that ended the automatic portion of the diagnostics. If there is no activity on the keypad within approximately 60 seconds after the diagnostics have ended, the sampler will automatically be transferred to the standby state.

**Terminate diagnostics** OFF - Pressing the OFF key terminates the diagnostics and transfers the sampler to the off state.

ON - Pressing the ON key terminates the diagnostics and transfers the sampler to the standby state.

**Event mark** MANUAL SAMPLE - Pressing the MANUAL SAMPLE key causes a single check event mark signal to be sent out on pin E of the FLOW METER connector.



## MODEL 2900

Time base check	<b>START SAMPLING</b> - Pressing the <b>START SAMPLING</b> key causes 37.5 Hz, 12 volt square wave to be sent out on pin E of the FLOW METER connector. This signal is a measure of the time base of the sampler, and should be accurate to within $\pm 0.0833\%$ . This signal is present for approximately two minutes, and may be terminated by pressing any key except <b>START PROGRAM/RESET DISTRIBUTOR</b> .
Distributor checks	<b>NEXT BOTTLE</b> - Pressing the <b>NEXT BOTTLE</b> key starts the distributor diagnostic routine. The distributor will run in reverse to just ahead of the first bottle, then run forward to just beyond the twenty-fourth bottle. Pressing <b>ON</b> reverses back to the first bottle position; then the distributor will advance to the bottle it was on when the diagnostic started. (The diagnostic assumes that the sampler is using the 24 bottle modes.) If a hard error is detected in the distributor's optical system during this diagnostic routine, distributor movement will cease, and an error message will be displayed. The display will alternate between two EEs ("EE-") and either a 3 (" 3"), a 4 (" 4"), or a 5 (" 5"). A 3 represents a time out error, indicating that the distributor limits were not reached within an allowable time interval. A 4 represents a bottle number 1/24 phase error, indicating that a mismatch in timing was noted between the occurrence of the first or last bottle position and the distributor limit indicators. A 5 represents a total number of bottles error, indicating that more or less than the correct number (24) of bottles were detected.
Pump tests	<b>PUMP JOG FWD</b> - Pressing the <b>PUMP JOG FWD</b> key causes the forward pump test of the automatic portion of the test to be repeated. This again ends with the display rotating between two numbers.  <b>PUMP JOG REV</b> - Pressing the <b>PUMP JOG REV</b> key causes the same pump test to be run, except in the reverse direction.
Clearing error messages	An error message generated during the manually initiated diagnostics may be cleared from the display only by powering the unit down and back up. Upon power up, the display will return to the rotation of the two numbers that ended the automatic portion of the diagnostics.
6.6 Troubleshooting - The	electronic circuitry of the Model 2900 is almost completely solid state, and its reliability is usually high. If the unit should fail to operate properly, the problem will most likely be mechanical. Items such as a broken or intermittent connection in the power cable or wiring harness should be suspected.
Factory service recommended	If an electronic problem is suspected, Isco strongly recommends that the sampler be returned to the factory for servicing. Due to the complex nature of the microprocessor-based sampler circuitry, specialized knowledge and instrumentation are required for troubleshooting. The Isco service department has the trained technicians and specially designed equipment necessary for timely, efficient troubleshooting and repair of the Model 2900 Sampler.
User servicing	To reiterate, Isco believes that the user will normally be time and money ahead to return the sampler to the factory for service. However, if the user has the facilities and desires to service the unit her or himself, she or he is, of course, free to do so. In this case, the best aid to troubleshooting is a thorough understanding of the sampler circuitry, as described in section 5.2. The Isco Customer Service Department (at the location listed in the preface to this manual) is available to provide additional information and advice with regard to servicing.
Troubleshooting hints	Following are some hints which may be of use in troubleshooting the sampler. In attempting to isolate problems with the unit, the CPU and memory should be assumed to be working properly until attempts to find problems in peripheral circuitry have been exhausted. This is for two reasons. First, the likelihood of failure is far greater on transistor drive circuits, etc., than it is on the CPU or memory. Second, it is doubtful if the repair facility would have the equipment or the time to do meaningful troubleshooting on the CPU or memory.
Questions to be answered	The first questions to be answered when a problem exists are. Is the 5 volt rail up? Is there a shorted or open drive transistor? Is there a cold solder joint? These are the type of questions to be answered before attempting to troubleshoot the CPU and memory.

## MODEL 2900

**CPU checks**                      Some checks on CPU operation can be made, however, with an oscilloscope operating at a high sweep rate (1M Hz or greater). If either of both SC0 or SC1 outputs (pins 6 and 5) of the CPU show activity, the CPU is at least running, and executing some part of the program. If no activity is present, the clear line to the CPU should be checked. It should be high. If not, circuitry external to the CPU is stopping the CPU. If it is high and the CPU is not running, check the terminals of the crystal to see if the oscillator is running. It should always run.

**Troubleshooting guide**        To aid in troubleshooting relatively simple problems with the sampler, a troubleshooting guide is presented in Table 6.6-1.

**Return of unit to factory**        If trouble symptoms persist and cannot be located, ship the unit to the factory or consult our Customer Service Department, at the location listed in the preface to this manual.

**6.7 Replacement Parts List** - An illustrated list of common replacement parts for the Model 2900 Sampler can be found in Table 6.7-1. When ordering a replacement part, be sure to include the Isco assembly or part number, a complete description, and the serial number of the sampler on which the part is to be used. The serial number can be found on the tag affixed to the side of the sampler control unit.

**Table 6.6-1 Model 2900 Troubleshooting Guide**

SYMPTOM	PROBABLE CAUSE	SOLUTION
1. Sampler completely inoperative; display does not light.	a. Dead battery b. Blown fuse	a. Replace or recharge battery b. Replace fuse; see section 6.1.
2. Sample volumes incorrect	a. Pump tubing installed incorrectly b. Defective pump tubing c. Suction head or suction line values incorrectly programmed.	a. Install pump tubing per instruction in section 3.2. b. Replace pump tubing c. Program per section 2.2
3. Pump cycles on and off during sampling cycle	Low battery	Replace or recharge battery
4. Display reads "HELP"	a. Low battery b. Sampler's pump jammed by ice, broken pump tube, or foreign object	a. Replace or recharge battery b. Unjam pump
5. Display reads "----"	a. Distributor still moving at time of sample initiation b. Distributor jammed or broken	a. Wait for distributor to be positioned properly over bottle b. Check for obvious impediments; consult factory
6. Display reads "PPPP" or "EEEE"	a. Low battery b. Failed PROM or RAM check during power up	a. Replace or recharge battery b. Consult factory
7. Display reads "-EE-," possibly alternating with a " 1" or " 2"	Failed PROM or RAM check while in off, standby or run states	Consult factory
7. Display reads "-EE-," possibly alternating with a " 3" or " 4"	Distributor jammed or broken	Check for obvious impediments; consult factory

MODEL 2900

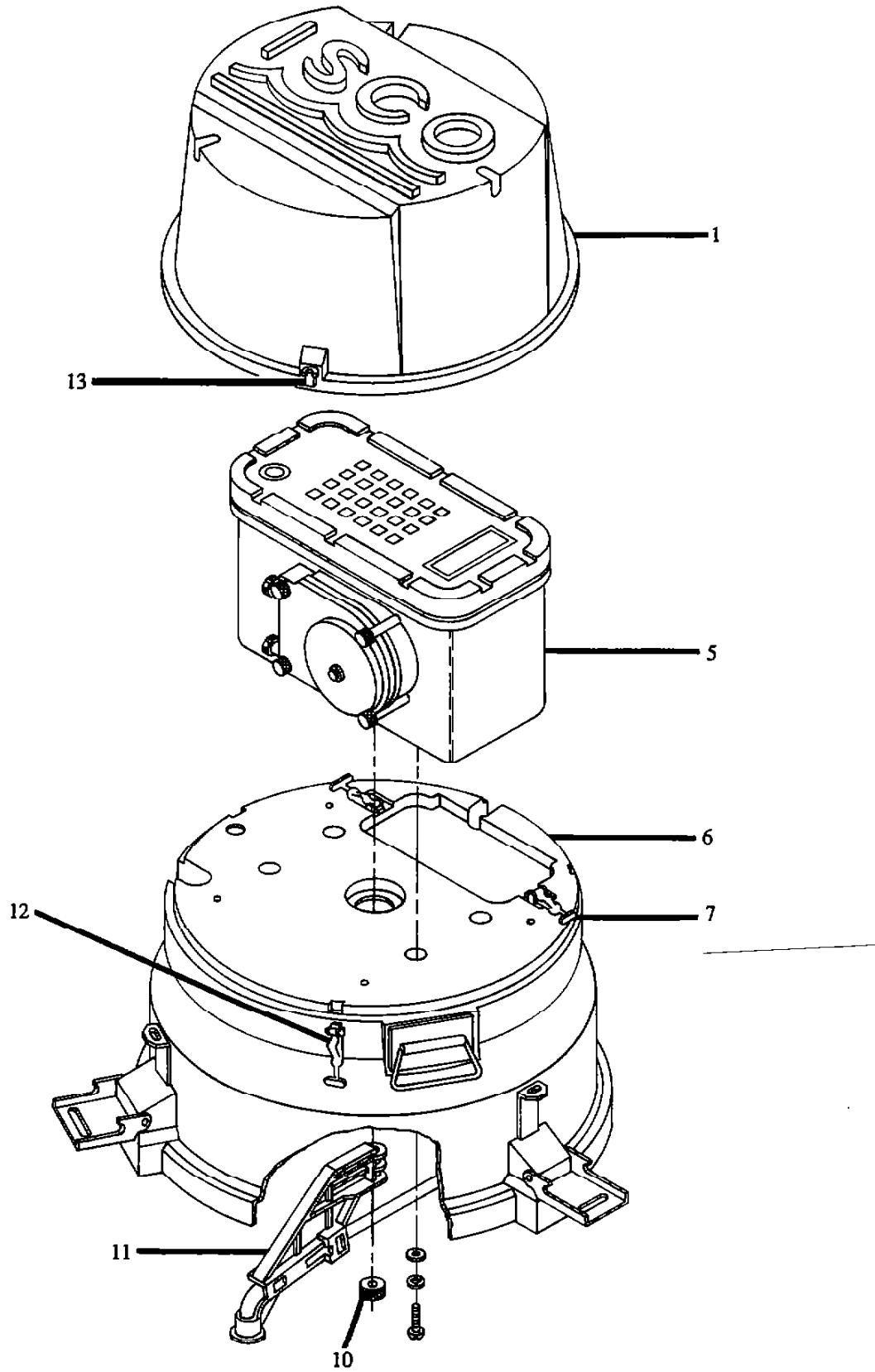

MODEL 2900

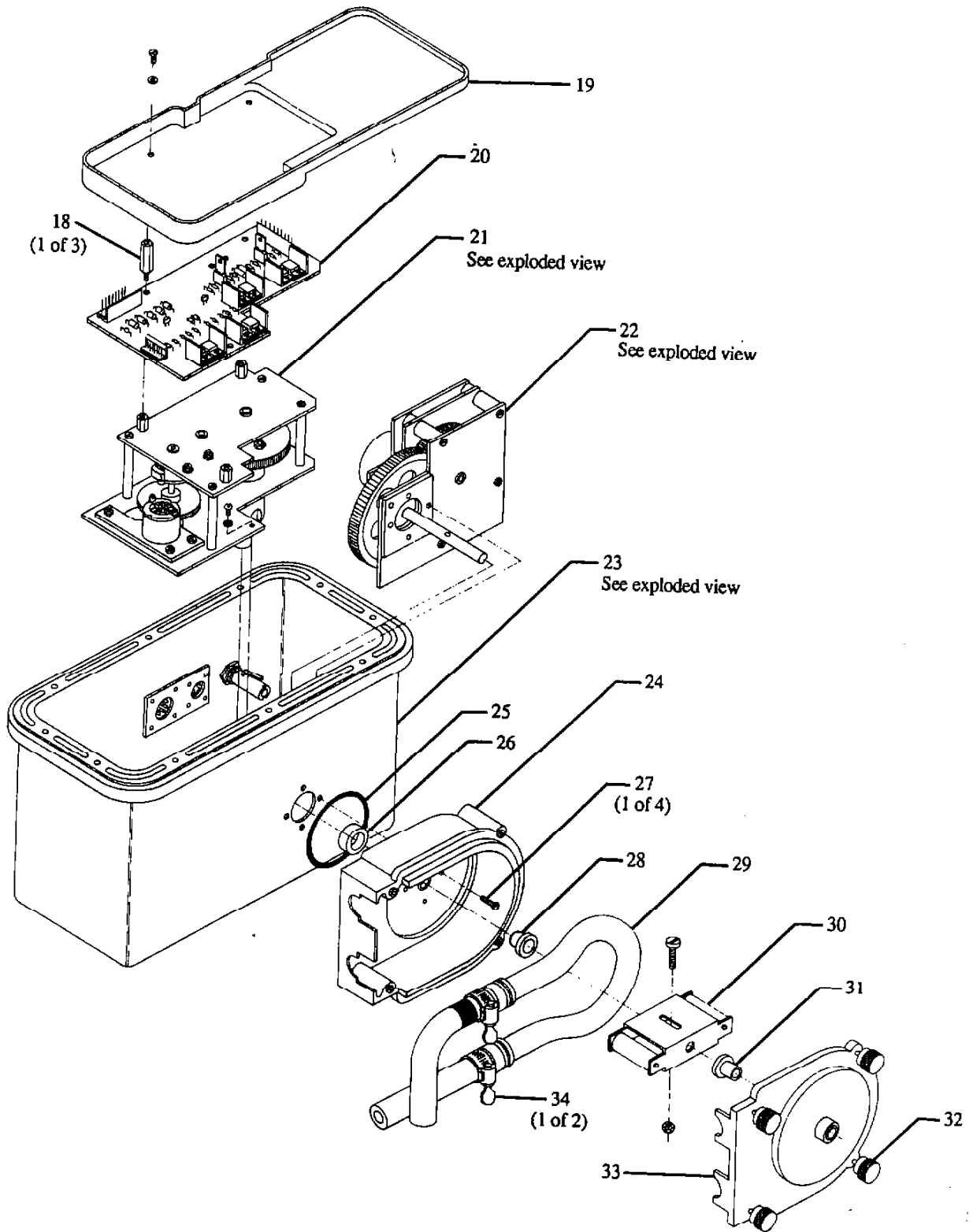

MODEL 2900

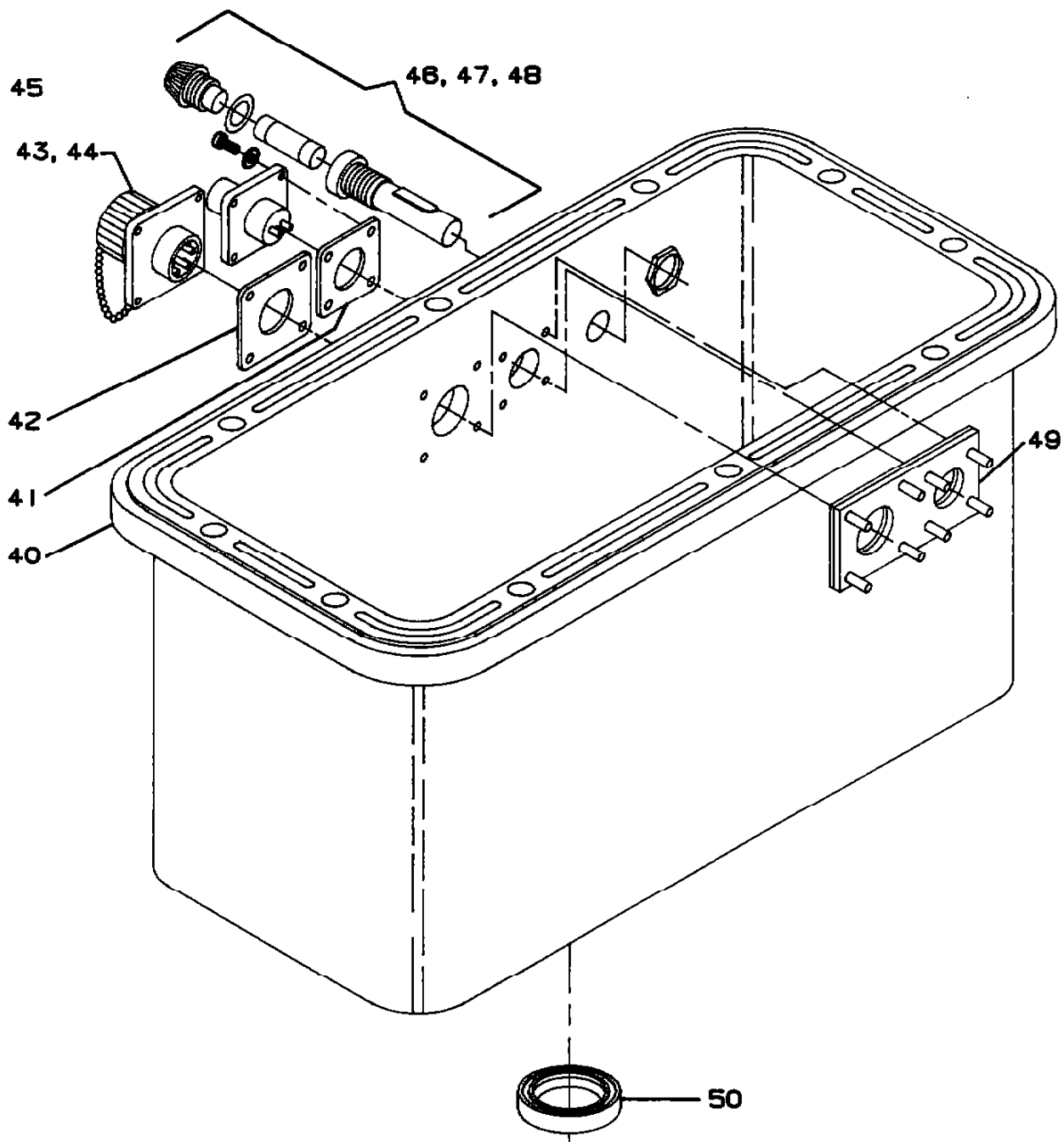

MODEL 2900

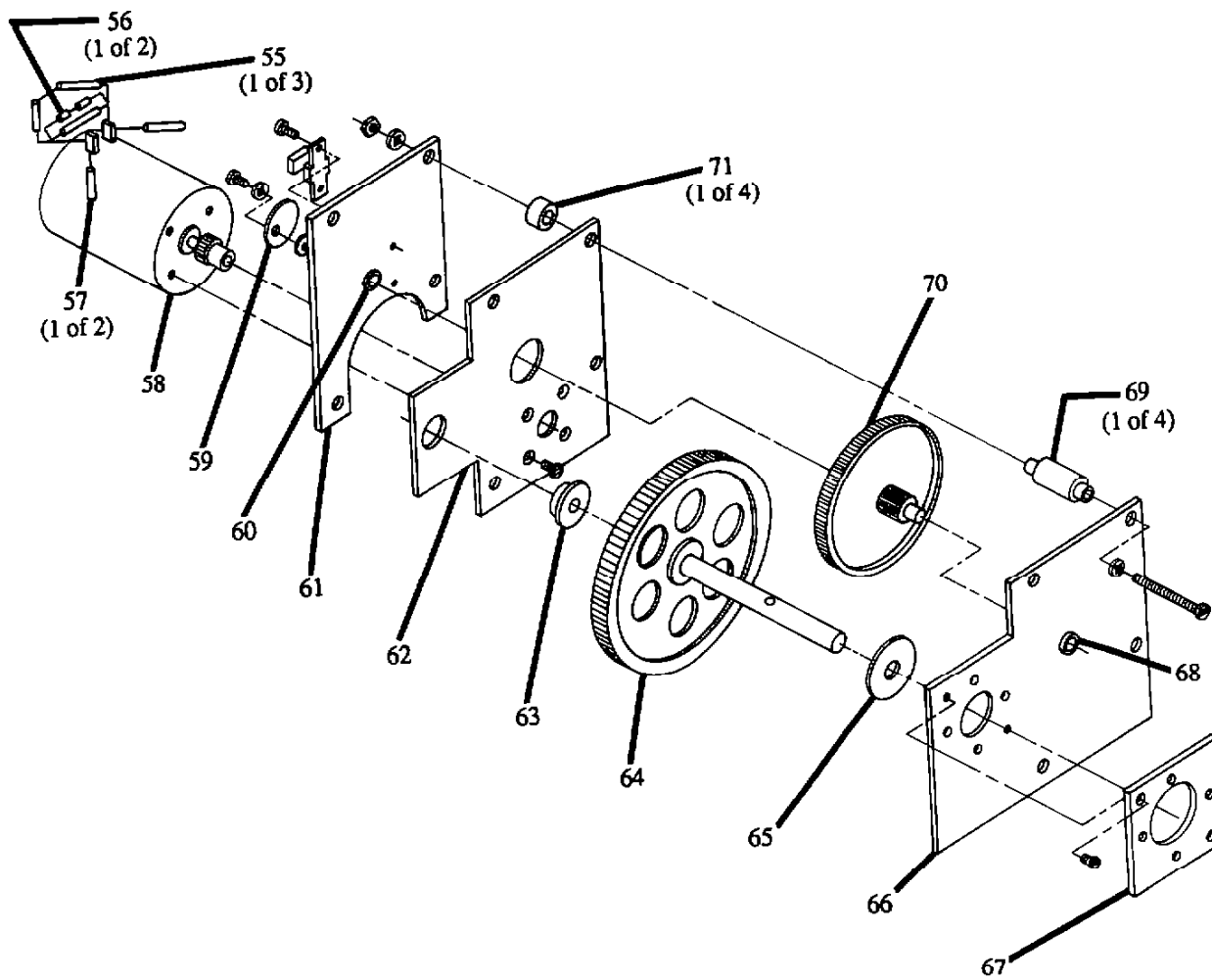

MODEL 2900

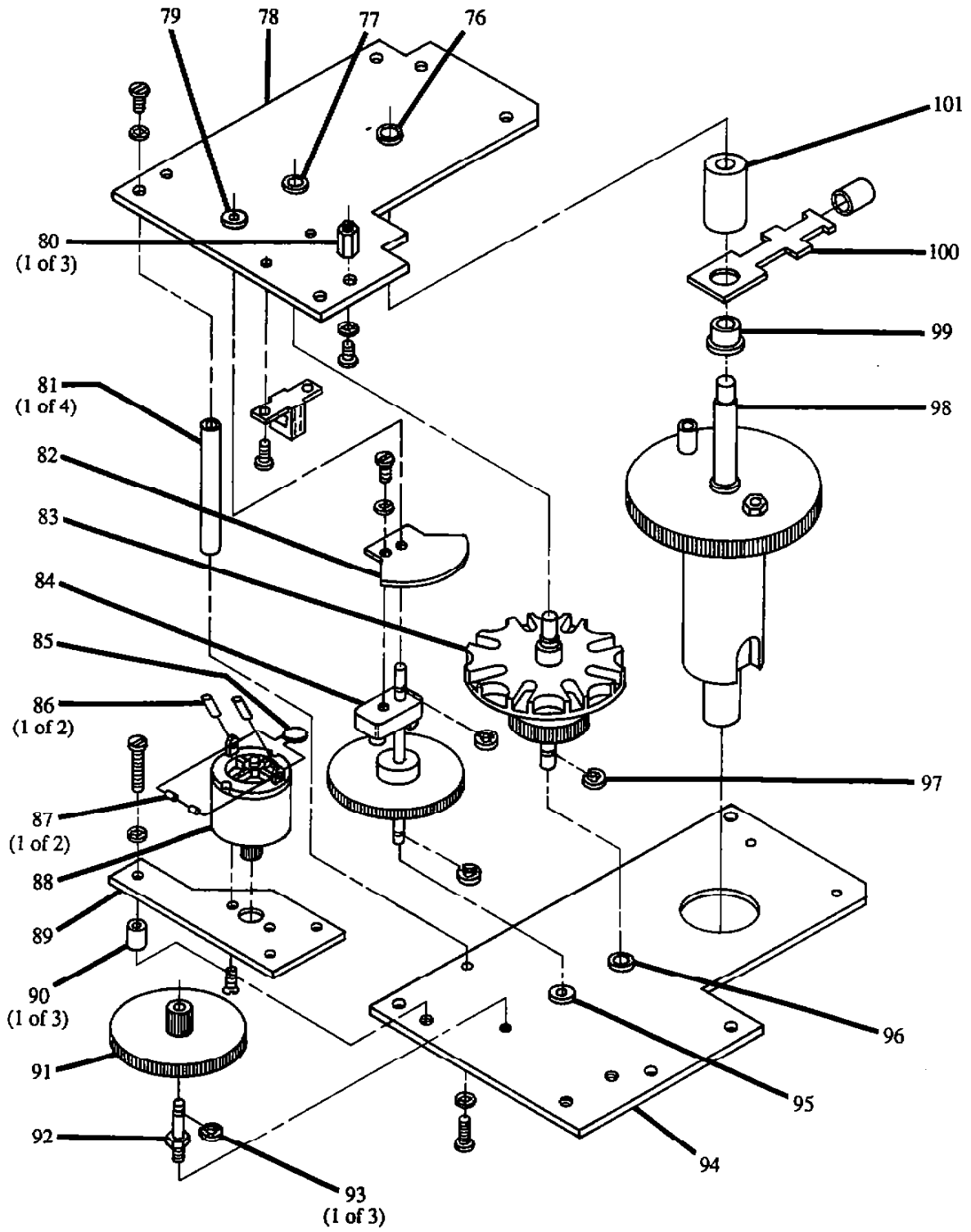

MODEL 2900

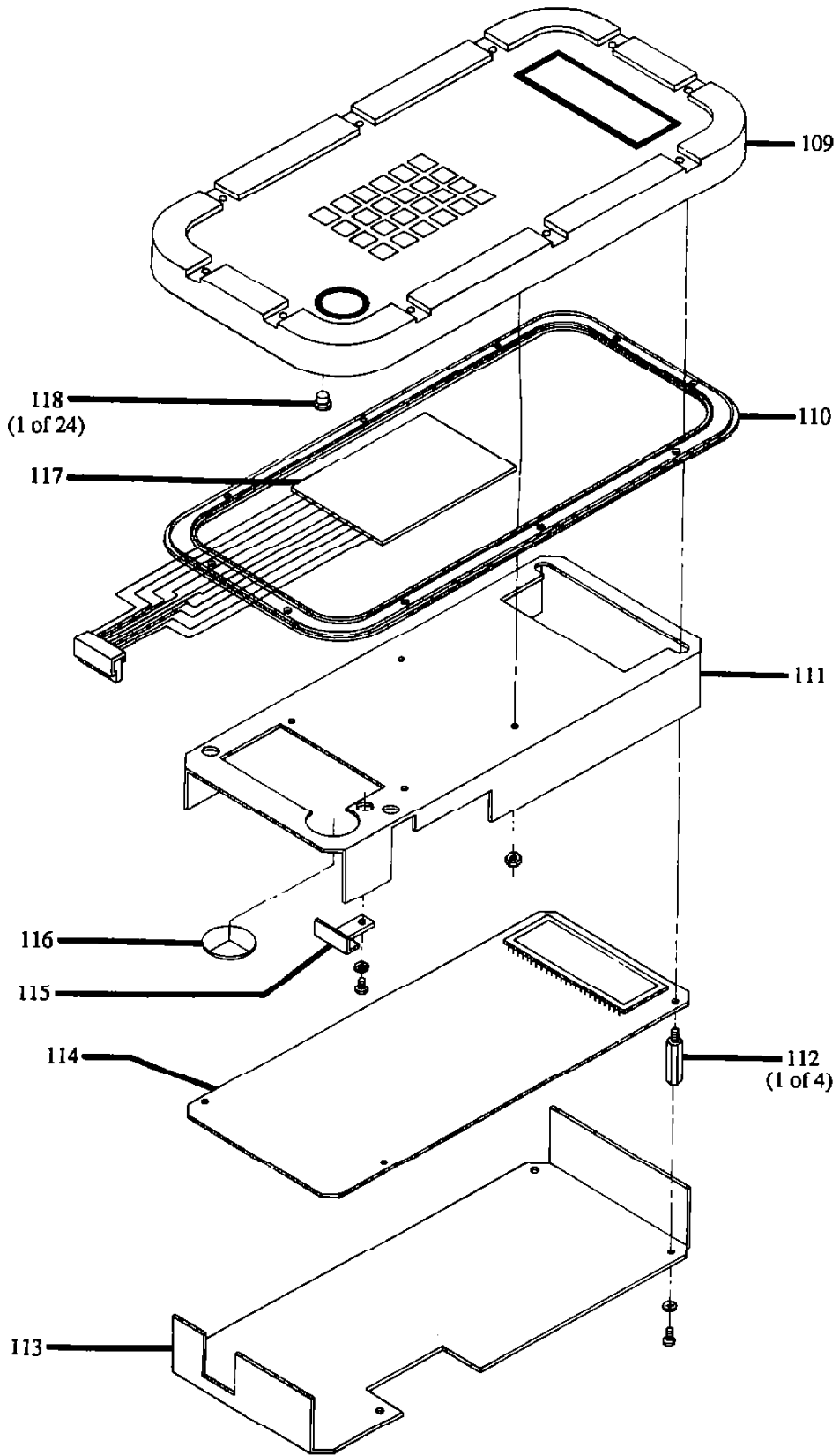



MODEL 2900

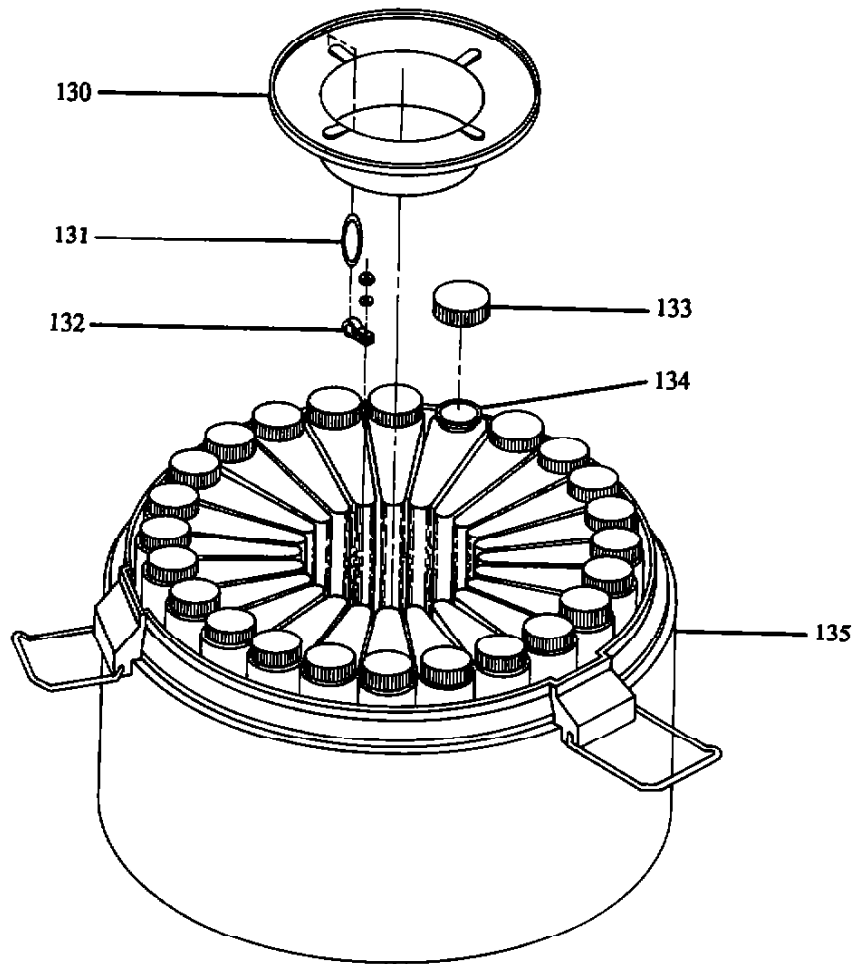
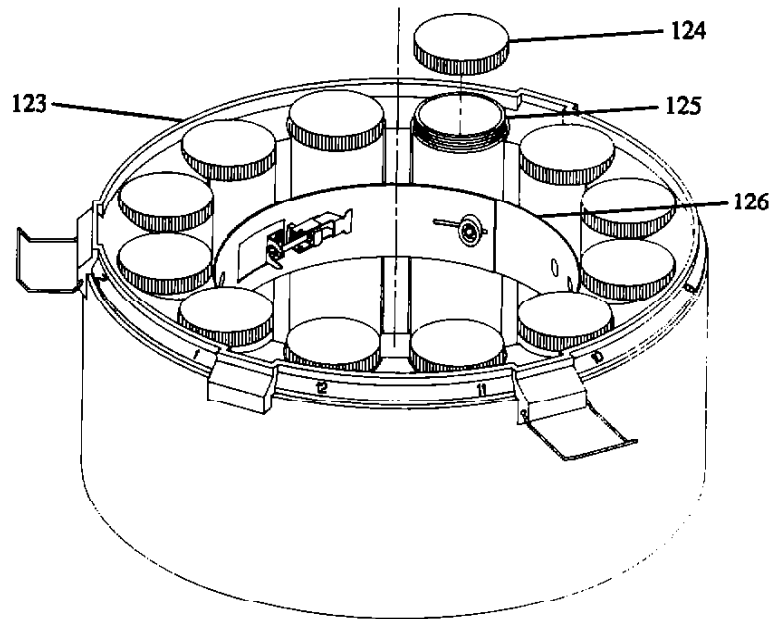

**MODEL 2900 SAMPLER  
REPLACEMENT PARTS LIST**

<b>ITEM NO.</b>	<b>COMPLETE ASSEMBLY</b>	<b>INDIVIDUAL PARTS</b>	<b>DESCRIPTION</b>
1	60-2904-002		Top Cover Assy
5	68-2900-005		Model 2900 RPL Control Box
6	60-2904-003		Center Section Assy.
7		109-0605-01	Draw Catch - Small
10		60-2923-007	Distributor Arm Nut
11		60-2903-008	Distributor Arm
12		109-0601-01	Draw Catch - Large
13		60-1393-142	Draw Catch Keeper Mod
18		60-2903-063	Desiccant Tray Standoff
19		60-2903-062	Desiccant Tray
20		60-2904-022	Power Circuit Board Assy. - Q.A.
21	60-2904-007		Distributor Gear Case Assy.
22	60-2904-008		Pump Gear Case Assy.
23	60-2904-010		Control Box Sub. Assy.
24	60-2704-024 60-2704-100		Pump Housing Assy. - Inside (Before S/N 6830-001) Pump Housing Assy. - Inside (Starting with S/N 6830-001)

\*Not Shown

**MODEL 2900 SAMPLER  
REPLACEMENT PARTS LIST**

ITEM NO.	COMPLETE ASSEMBLY	INDIVIDUAL PARTS	DESCRIPTION
25		202-1001-35	O-Ring #135
26		202-9999-03	Lip Seal 3/4" Bore 3/8" Shaft
27		231-9145-12	SST 8-32 X 3/4" Self Sealing Screw
28		60-2703-106 60-3703-012	Pump Housing Bearing - Inside (Before S/N 6830-001) Pump Housing Bushing - Inside (Starting with S/N 6830-001)
29		60-2704-044	Pump Tubing Assy. 35"
30		60-2704-019	Pump Rotor Assy.
31		60-2703-107 60-3703-012	Pump Housing Bearing - Outside (Before S/N 6830-001) Pump Housing Bushing (Starting with S/N 6830-001)
32		60-2703-044	Pump Housing Thumbscrew
33	60-2704-025 60-2704-098		Pump Housing Assy. - Outside (Before S/N 6830-001) Pump Housing Assy. - Outside (Starting with S/N 6830-001)
34		60-2704-011	Tubing Clamp Assy.
35		099-0002-08	Humi-sorb Desiccant Bag - 4 oz.*
40		60-2904-027	Control Box Mod. Assy.
41		60-1393-082	Seal Gasket for Amp 2 Pin
42		60-1473-057	Seal Gasket for Amp Plug
43		140-1006-00	Amp Panel Mt. MS3102A-14S-6P
44		149-1001-00	Amp Dust Cover MS9760-14
45		140-1002-01	Amp Panel Mt. MS3102R-10SL-4P
46		60-2703-079	Fuse Holder Mod.
47		202-1001-07	O-Ring #107 Buna-N
48		411-0311-62	Fuse 3AG 2 Amp SB 125V

\*Not Shown

**MODEL 2900 SAMPLER  
REPLACEMENT PARTS LIST**

<b>ITEM NO.</b>	<b>COMPLETE ASSEMBLY</b>	<b>INDIVIDUAL PARTS</b>	<b>DESCRIPTION</b>
49		60-2904-071	Conn Backing Plate Assy. w/ Gasket
50		202-9999-04	Lip Seal 1-1/2" Bore 1" Shaft
55		113-3245-00	Capacitor .047 MFD 100V
56		400-2147-13	Zener Diode 1N4744A 15V 1W
57		120-0001-00	Ferrite Bead
58		60-2904-017	Pump Motor Assy.
59		60-2903-046	Pump Encoder Disc
60		201-3123-00	Bearing Bronze Fl .252 ID .377 OD
61		60-2904-021	Rear Support Plate Assy.
62		60-2903-022	Pump Support Motor Plate
63		60-2903-017	Pump Shaft Bearing
64		60-2904-019	Pump Shaft Assy.
65		60-2703-058	Pump Shaft Spacer
66		60-2904-020	Pump Support Plate Assy.
67		60-2703-037	Pump Shaft Spacer Plate
68		201-3123-00	Bearing Bronze Fl .252 ID .377 OD
69		60-2903-018	Pump Spacer
70		60-2904-018	Pinion Shaft Assy.
71		60-2903-019	Pump Spacer, Short

**MODEL 2900 SAMPLER  
REPLACEMENT PARTS LIST**

ITEM NO.	COMPLETE ASSEMBLY	INDIVIDUAL PARTS	DESCRIPTION
76		201-3123-00	Bearing Bronze Fl .252 ID .377 OD
77		201-3115-00	Bearing Bronze Fl .189 ID .314 OD
78	60-2904-014		Distributor Top Plate Assy.
79		201-3113-00	Bearing Bronze Fl .127 ID .315 OD
80		237-3024-00	Spacer Alum 1/4" Hex 4-40 X 3/8"
81		60-2903-034	Distributor Plate Spacer
82		60-2903-031	Encoder Disc
83		60-2904-012	Geneva Wheel Shaft Assy.
84		60-2904-011	Driver Arm Shaft Assy.
85		119-0203-00	Cap. Ceramic .1uf 25V
86		120-0001-00	Ferrite Bead
87		400-2147-13	Zener Diode 1N4744A 15V 1W
88		60-2704-003	Distributor Motor Assy.
89		60-2903-036	Distributor Motor Plate
90		60-2903-033	Distributor Motor Spacer
91		60-2703-062	Distributor Gear Mod
92		60-2903-029	Idler Shaft
93		209-0005-01	SST Retaining Ring 5133-12H
94		60-2904-015	Distributor Bottom Plate Assy. (includes items 95 and 96)
95		201-3113-00	Bearing Bronze Fl .127 ID .315 OD
96		201-3115-00	Bearing Bronze Fl .189 ID .314 OD

\*Not Shown

**MODEL 2900 SAMPLER  
REPLACEMENT PARTS LIST**

<b>ITEM NO.</b>	<b>COMPLETE ASSEMBLY</b>	<b>INDIVIDUAL PARTS</b>	<b>DESCRIPTION</b>
97		209-0006-00	SST Retaining Ring 5133-18H
98		60-2904-013	Distributor Shaft Assy.
99		60-2903-040	Locking Lever Bearing
100		60-2903-042	Locking Lever
101		60-2903-039	Hold Down Locking Lever
109		60-2904-067	Cont. Panel Sub. Assy. - 2900 Series
110		60-2903-011	Control Box Gasket
111		60-2903-050	Keyboard Support
112		60-2903-056	CPU Shield Spacer
113		60-2903-051	CPU Shield
114	60-2904-023		Main Circuit Board Assy. - Q.A.
115		60-2703-064	Humidity Indicator Hold Down
116		490-0013-00	Humidity Indicator Card
117		60-2904-026	Keypad Wiring Harness
118		60-2903-083	Keyboard Button Molded

\*Not Shown

**MODEL 2900 SAMPLER  
REPLACEMENT PARTS LIST**

<b>ITEM NO.</b>	<b>COMPLETE ASSEMBLY</b>	<b>INDIVIDUAL PARTS</b>	<b>DESCRIPTION</b>
123	60-2904-058		Sample Bottle Tub
124	60-1684-153		Teflon Lined Glass Cap Assy.
125		60-1683-090	Glass Bottle (New Style)
126		60-2904-062	12 Bottle Expander Ring
130		60-2903-127	Bottle Retaining Ring
131		60-3704-111	Bottle Hold Down Cord Assy.
132		489-0002-00	Cable Clamp Nylon 1/4 In.
133		299-0334-00	500 ml Bottle Cap w/Foam Liner
134		60-2903-006	500 ml Sample Bottle
135		60-2904-035	Sample Bottle Tub Assy.
137	68-2900-002		24 - 500 ml Polyeth. Btls. w/Caps*
138		60-2903-006	500 ml Sample Bottle*
139		299-0334-00	500 ml Bottle Cap w/Foam Liner*
141*	60-2904-064		2900 Composite Btl Locating Assy. (includes items 142 and 143)
142*		60-2904-066	Strap Assembly
143*		60-2904-065	Insert Assembly
144*		60-2904-059	Pump Tubing Assy. - 29"

\*Not Shown





## **One Year Limited Warranty \*** **Factory Service**

Isco instruments covered by this warranty have a one-year limited warranty covering parts and labor.

Any instrument that fails during the warranty period, due to faulty parts or workmanship, will be repaired at the factory at no charge to the customer. Isco's exclusive liability is limited to repair or replacement of defective instruments. Isco is not liable for consequential damages.

Isco will pay surface transportation charges both ways within the 48 contiguous United States if the instrument proves to be defective within 30 days of shipment. Throughout the remainder of the warranty period, the customer will pay to return the instrument to Isco, and Isco will pay surface transportation to return the repaired instrument to the customer. Isco will not pay air freight or customer's packing and crating charges.

The warranty for any instrument is the one in effect on date of shipment. Warranty period

begins on the shipping date, unless Isco agrees in writing to a different date.

Excluded from this warranty are normal wear; expendable items such as charts, ribbon, tubing, and glassware; and damage due to corrosion, misuse, accident, or lack of proper maintenance. This warranty does not cover Isco on-line Process Analyzers and certain Isco SFE instruments, which are covered under different warranty terms, nor does it cover products not sold under the Isco trademark or for which any other warranty is specifically stated in sales literature.

This warranty is expressly in lieu of all other warranties and obligations and Isco specifically disclaims any warranty of merchantability or fitness for a particular purpose. Any changes in this warranty must be in writing and signed by a corporate officer.

The warrantor is Isco, Inc. 4700 Superior, Lincoln, NE 68504, U.S.A.

\* This warranty applies to USA customers. Customers in other countries should contact their Isco dealer for warranty service.

Before returning any instrument for repair, please call, fax, or e-mail the Isco service department for instructions. Many problems can often be diagnosed and corrected over the phone, or by e-mail, without returning the instrument to the factory.

Instruments needing factory repair should be packed carefully, preferably in the original carton, and shipped to the attention of the service department. Small, non-fragile items can be sent by insured parcel post. **PLEASE BE SURE TO ENCLOSE A NOTE EXPLAINING THE DEFECT.**

**Return instruments to:** Isco, Inc. - Attention Repair Service  
4700 Superior Street  
Lincoln NE 68504 USA

**Mailing address:** Isco, Inc.  
PO Box 82531  
Lincoln NE 68501 USA

**Phone:** Repair service: (800)775-2965 (lab instruments)  
(800)228-4373 (samplers & flowmeters)  
Sales & General Information (800)228-4373 (USA & Canada)

**Fax:** (402) 465-3001

**Email:** service@isco.com