

Gilian[®]
Gilibrator 2
CALIBRATION SYSTEM
OPERATION & SERVICE MANUAL

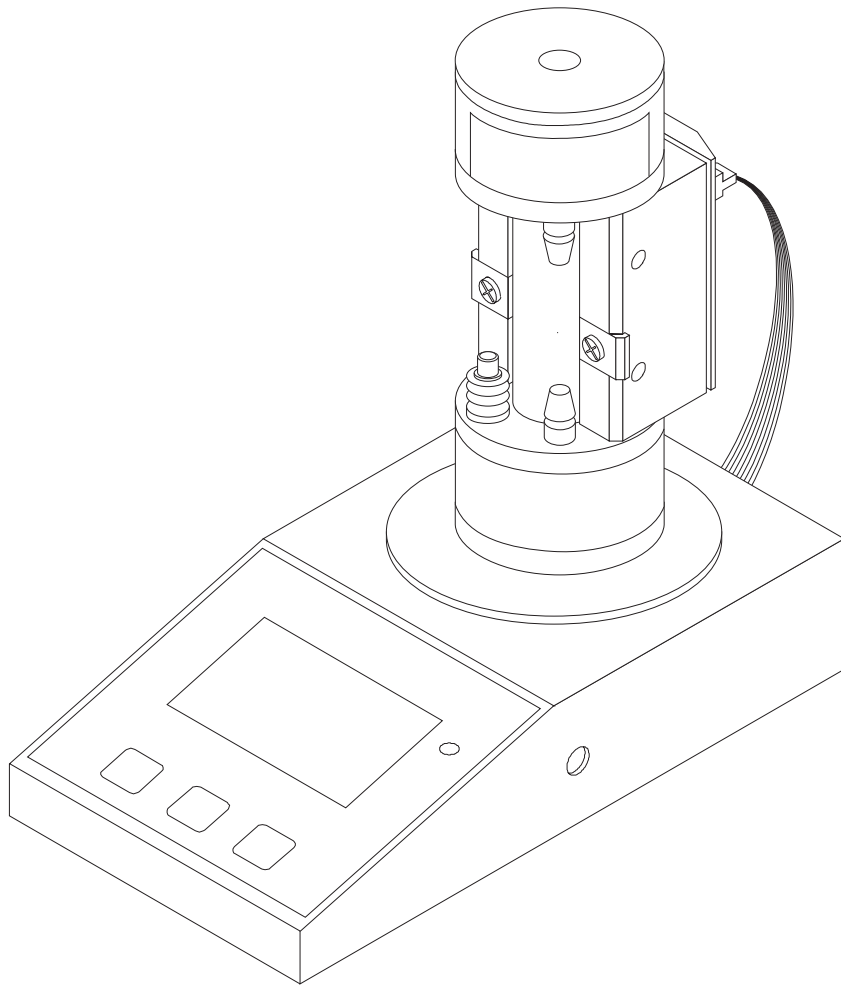

SENSIDYNE[®]

16333 Bay Vista Dr. • Clearwater, FL 33760 • (800) 451-9444 • (727) 530-3602 • (727) 539-0550 [FAX] • www.Sensidyne.com

Revision G • Document No. 850190M

LETTER FROM THE PRESIDENT

Thank you for purchasing your new Sensidyne air monitoring product. We stand behind all of the products we sell . . . each Sensidyne product has been designed and manufactured to provide unparalleled service, day after day. Our professional staff has tested each unit under the strictest conditions possible to ensure successful, accurate results every time. With the minimal care and maintenance described in this *Operation & Service Manual*, the Sensidyne product you have purchased will give you many years of reliable service.

Our only goal is that you are pleased with the quality, performance, and accuracy of your Sensidyne product. Be assured of our complete and prompt answers to any questions you may have about this product, since we are totally committed to providing you with fast, responsive customer service and technical support.

If you ever have difficulty solving a problem with any Sensidyne product, or if you are not 100% satisfied with the service you receive from any level of our organization, please let me know about it. Call me at either of the numbers listed below, and I will personally research your problem to ensure that it is resolved in a manner that is satisfactory to you. Your satisfaction with our products and service is of the utmost importance to me.

Sincerely,

Carl Mazzuca

Carl Mazzuca
President, Sensidyne, Inc.

800-451-9444
727-530-3602
Fax: 727-539-0550

PACKING LIST

The following are shipped with the **Gilian Gilibrator 2 Calibration System Standard Kits**:

- Control Unit Base
- Flow Cell Assembly
(Piston or Wet [High Flow, Standard Flow, or Low Flow])
- AC Charger
- Adapter [shipped with non-CE control base units]
- Tubing
- Small Carrying Case
- Soap Solution & Dispenser (Wet Cells only)
- Calibration Certificate
- *Operation and Service Manual*

***ALWAYS check to make certain
you have received all of the items listed above.***

***If you have any questions or need assistance,
contact your Sensidyne Sales Representative, or call***

**(800) 451-9444
OR
(727) 530-3602**

IMPORTANT NOTE

(effective 7/1/99)

CE approved Control Unit Bases have 9-Pin cables and CANNOT be used with Piston Cells. Non-CE Control Unit Bases have 15-Pin cables and can be used with Piston Cells.

PROPRIETARY NOTICE

This manual was prepared by Sensidyne, Inc. exclusively for the owner of the Gilian Gilibrator 2 Calibration System. The material within this manual is the proprietary information of Sensidyne, Inc. and is to be used only to understand, operate, and service the instrument. By receiving this document, the recipient agrees that neither this document nor the information disclosed within nor any part shall be reproduced or transferred, physically, electronically or in any form or used or disclosed to others for manufacturing or for any other purpose except as specifically authorized in writing by Sensidyne, Inc.

COPYRIGHT NOTICE

© 2000 Sensidyne, Inc. All rights reserved. Information contained in this document is protected by copyright. No part of this document may be photocopied, reproduced, or translated to another program or system without prior written authorization from Sensidyne, Inc.

TRADEMARK NOTICE

Sensidyne, the Sensidyne logo, Gilian, and the Gilian logo are registered trademarks of Sensidyne, Inc. Gilibrator 2 and the Gilibrator 2 logo are trademarks of Sensidyne, Inc. The trademarks and service marks of Sensidyne, Inc. are protected through use and registration in the United States.

DISCLAIMER

SENSIDYNE, INC. ASSUMES NO RESPONSIBILITY WHATSOEVER, TO ANY PARTY WHOSOEVER, FOR ANY PROPERTY DAMAGE, PERSONAL INJURY, OR DEATH RECEIVED BY OR RESULTING FROM, IN WHOLE, OR IN PART, THE IMPROPER USE, INSTALLATION, OR STORAGE OF THIS PRODUCT BY THE USER, PERSON, FIRM, ENTITY, CORPORATION OR PARTY NOT ADHERING TO THE INSTRUCTIONS AND WARNINGS OR NOT ADHERING TO ALL FEDERAL, STATE, AND LOCAL ENVIRONMENTAL AND OCCUPATIONAL HEALTH AND SAFETY LAWS AND REGULATIONS.

THE SELLER SHALL NOT BE LIABLE FOR DIRECT, INDIRECT, CONSEQUENTIAL, INCIDENTAL OR OTHER DAMAGES RESULTING FROM THE SALE AND USE OF ANY GOODS AND SELLER'S LIABILITY HEREUNDER SHALL BE LIMITED TO REPAIR OR REPLACEMENT OF ANY GOODS FOUND DEFECTIVE. THIS WARRANTY IS IN LIEU OF ALL OTHER WARRANTIES, EXPRESSED OR IMPLIED, INCLUDING BUT NOT LIMITED TO THE IMPLIED WARRANTIES OF MERCHANTABILITY AND FITNESS FOR USE OR FOR A PARTICULAR PURPOSE WHICH ARE EXPRESSLY DISCLAIMED.

TABLE OF CONTENTS

• PREFACE

• Packing List	3
• Notices	4
• WARNING	7

SECTION ONE: INTRODUCTION

1.1 Overview	8
1.2 Theory of Operation	8

SECTION TWO: COMPONENTS

2.1 Control Unit	9
2.1.1 Buttons & Indicators	9
2.1.2 Display Characters	9
2.1.3 Interface Components	9
2.2 Piston Cell Assembly	12
2.3 Wet Cell Assembly	12
2.3.1 Bubble Generator Components	12
2.3.2 Sensor Block	14

SECTION THREE: SET-UP

3.1 System Set-Up	16
3.2 Cell Assembly Set-Up	16
3.2.1 Cell Assembly Mounting	16
3.2.2 Cabling Connections	20
3.2.3 Adding Soap Solution (Wet Cell only)	20
3.2.4 Sampling Source Connection	20

TABLE OF CONTENTS

SECTION FOUR: OPERATION

4.1	Piston Cell Operation	22
4.1.1	Start Up	22
4.1.2	Flow Readout.....	22
4.2	Wet Cell Operation	23
4.2.1	Start Up	23
4.2.2	Bubble Generation	23
4.2.3	Flow Readout.....	23

SECTION FIVE: MAINTENANCE

5.1	Storage	24
5.2	Piston Cell Maintenance	24
5.3	Wet Cell Maintenance	25
5.3.1	General Maintenance	25
5.3.2	Damper Plate Diaphragm	25
5.3.3	Additional Wet Cell Maintenance	25

SECTION SIX: APPENDICES

•	Appendix A: Parts List	27
•	Appendix B: Specifications	29
•	Appendix C: Returned Material Authorization	30

LIST OF FIGURES

2.1	Control Unit	10
2.2	Liquid Crystal Display	11
2.3	Piston Cell Assembly	13
2.4	Wet Cell Assembly (Exploded View)	15
3.1	Gilibrator 2 System Set-Up	17
3.2	Cell Assembly Mounting (3-D View)	18
3.3	Cell Assembly Mounting (Top View)	19
3.4	Adding Soap Solution (Wet Cell)	20
5.1	Wet Cell Assembly Maintenance	26



WARNINGS !



READ AND UNDERSTAND ALL WARNINGS BEFORE USE

IMPORTANT COMPATIBILITY NOTE

Most flow cells designed for the original Gilibrator base are compatible with the Gilibrator 2 base unit. If your existing flow cell is not compatible with the Gilibrator 2 base, the unit will display a false SAMPLE# reading immediately after start-up. If this happens, your flow cell needs to be returned to Sensidyne to be upgraded. See Appendix C for more information.

Read and understand **ALL** warnings before using this product. Failure to read, understand, and comply with **ALL** warnings could result in property damage, severe personal injury, or death.

Read and understand **ALL** applicable Federal, State, and Local environmental health and safety laws and regulations, including OSHA. Ensure complete compliance with **ALL** applicable laws and regulations before and during use of this product.

UNDER NO CIRCUMSTANCES should this product be used except by qualified, trained, technically competent personnel and not until the warnings, *Operation and Service Manual*, labels, and other literature accompanying this product have been read and understood.

The *Operation and Service Manual* must be read and understood by each user before operating this product or using its accessories, in order to ensure proper and safe use and installation of this product and to ensure familiarity with the proper treatment and safety procedures in the event of an accident.

DO NOT remove, cover, or alter any label or tag on this product, its accessories, or related products.

DO NOT operate this product should it malfunction or require repair. Operation of a malfunctioning product, or a product requiring repair may result in serious personal injury or death. **DO NOT** attempt to repair or modify the instrument, except as specified in the *Operation and Service Manual*. If repair is needed, contact the Sensidyne Service Department to arrange for a Returned Material Authorization (RMA).

Use **ONLY** genuine SENSIDYNE® replacement parts when performing any maintenance procedures described in this manual. *Failure to do so may seriously impair instrument performance.* Repair or alteration of the product beyond the scope of these maintenance instructions, or by anyone other than an authorized SENSIDYNE® serviceman, could cause the product to fail to perform as designed and persons who rely on this product for their safety could sustain severe personal injury or death.

ALWAYS turn off the instrument before changing any batteries.

ONLY use Soap Solution Part No. 800450 with the a Wet Flow Cell Assembly. Use of other soap solutions can damage the Flow Cell.

Piston Cell Warning: Do not close the bleeder valve on the piston cell assembly until the green ready light (LED) lights up.

IMPORTANT NOTE

(effective 7/1/99)

**CE approved Control Unit Bases have 9-Pin cables and CANNOT be used with Piston Cells.
Non-CE Control Unit Bases have 15-Pin cables and can be used with Piston Cells.**

SECTION ONE

INTRODUCTION

1.1 OVERVIEW

The Gilian Gilibrator 2 Calibration System is an easy to use Primary Standard for the calibration of air sampling equipment. The system includes a high accuracy, electronic flowmeter that provides instantaneous air flow readings and cumulative averaging of multiple samples. Three Wet Cell Assemblies and one Piston Cell Assembly provide a wide range of flow rates and are easily interchangeable using twist-on/off mounting.

A crystal controlled microprocessor Control Unit is designed for accurate data readings. A dual function **DELETE/RESET** button on the Control Unit subtracts erroneous readings to ensure accurate data, or can cancel the current readings completely.

A printer interface on the Control Unit allows you to output the sampling results to a printer or PC computer. Windows™ compatible Gilibrator 2 Flow Monitoring Software is available that allows you to collect, store, and plot flow samples.

Features of the Gilibrator 2 Calibration System include an easy-to-read display; simultaneous display of flow rate, flow average, and number of samples taken; display indicators for LOW BAT, WAIT, ERROR 1, and ERROR 2; and automatic power shutoff when the unit is inactive for 15 minutes. You can also specify the number of samples to be taken (5 to 95) in 5 sample increments.

Gilibrator 2 Calibration System Kits include either a Wet or Piston Cell Assembly, Control Unit Base (either CE or non-CE approved), Battery Charger, Tubing, and Soap Solution & Dispenser (Wet Cells only). A 15-to-9 pin adapter is included with the non-CE Control Base to allow it to operate with existing 9-pin Wet Cell Assemblies.

Interchangeable Flow Cell Assemblies are available as follows:

- Piston Cell (1 to 5 LPM)
- Low Flow Wet Cell (1 to 250 cc/m)
- Standard Flow Wet Cell (20 cc/m to 6 LPM)
- High Flow Wet Cell (2 to 30 LPM)

1.2 THEORY OF OPERATION

To be a primary standard, all values must be absolute and measured as absolute. A primary standard airflow measurement is a volume divided by a time interval as performed by the Control Unit of the Gilibrator 2. The volume (V) is measured volume of space between two infrared sensors. The time (t) is that interval needed for an object (soap film bubble or piston cell piston) to travel between the two sensors which bound the volume. Thus, the volume per unit of time (V/t) becomes the flow rate. Because the electronic clock is far more accurate than the volume measurements, the volume measurement accuracy determines the overall accuracy of the unit.

The Gilibrator 2 consists of two elements, the Flow Cell Assembly (either Wet or Piston) and the Control Unit Base. The function of the Flow Cell Assembly is to provide a means for measuring an object (soap film bubble or piston cell piston) traveling up a flow tube through a known volume of space.

Measurement of the travel time is done by means of “top” and “bottom” infrared sensor pairs mounted along the flow tube. The volume bound by these sensors is set accurately to a primary volume standard.

As the object (bubble or piston) moves up the tube, it trips the bottom sensor pair. As it moves further up the tube, it trips the top sensor pair. The time difference between the bottom and top sensors becomes the elapsed travel time. This timing information (along with the volume information) is sent to the microprocessor in the Control Unit Base. The calculated flow and sample information are then displayed directly on the Liquid Crystal Display.

2.1 CONTROL UNIT

The Control Unit (refer to Figures 2.1 & 2.2) contains a crystal-controlled microprocessor timing system. This type of microprocessor, used in conjunction with the built-in software, provides an extremely accurate method for calculating the flow rate parameters.

The Control Unit contains the following components:

2.1.1 Buttons & Indicators

The **ON** and **OFF** buttons turn the Control Unit on and off.

The **DELETE/RESET** button has three functions:

Pressing for 1 second deletes the most recent reading from the running average. It resets the average and sample number to the previous reading. If a printer is connected, a minus symbol is printed and the average returns to the previous value. If a computer is connected a minus symbol is displayed on the computer monitor and the average returns to the previous value.

Pressing for 3 seconds resets the current readings to zero and initiates a new sampling sequence. If a printer is connected, it prints a new header. If the Flow Monitoring Software is running, its graph will clear and a new sampling sequence will start.

Pressing simultaneously with the ON button sets the sample size. The sample size is adjusted in 5 sample increments by repeatedly pressing **DELETE/RESET** (range: 5–95).

Charge Indicator

This LED lights up when the batteries are charging.

2.1.2 Display Characters

FLOW

This shows the flow rate in either cubic centimeters per minute (ccm) or liters per minute (lpm) depending on the Flow Cell Assembly used.

AVERAGE

Shows the average flow rate for the samples taken.

SAMPLE

Shows the number of samples taken (MAX = 99).

LOW BAT

This warning is displayed if insufficient battery charge remains to operate the unit properly. If the battery is not recharged, the unit automatically shuts off shortly after this message appears.

NOTE

Batteries must be fully charged for unit to function properly.

WAIT

Indicates there is a flow measurement in progress.

ERROR 1

Indicates trouble with the Flow Cell connection or adjustment.

ERROR 2

If this message appears call the factory.

2.1.3 Interface Components

Charging Jack

A 2.1 mm barrel jack that supports a standard AC/DC charger/adaptor. With the charger/adaptor the unit can be operated while continuously plugged into a wall socket. Or, the charger can be used to charge the unit overnight (14 hours) prior to operation in the field.

Printer Jack

A 25-pin printer connector allows the unit to be connected to: a) a Thermal Printer, b) a PC compatible dot-matrix or ink jet printer, c) an PC computer. The jack connects to a printer using a standard DB-25 to Centronics printer cable. A Gilibrator 2 Flow Monitoring Software Kit is available. The kit includes an operating manual, special cable, and software.

Cable Assembly

The 9-Pin or 15-pin cable assembly connects to the Connecting Jack located on the back of the flow cell assembly. On piston cell assemblies the cable directly connects to the cell assembly 15-pin jack. Wet cell assemblies require a 15-to-9 pin adapter.

NOTE

Only non-CE Control Bases with 15-Pin cable assemblies can be used with Piston Cells.

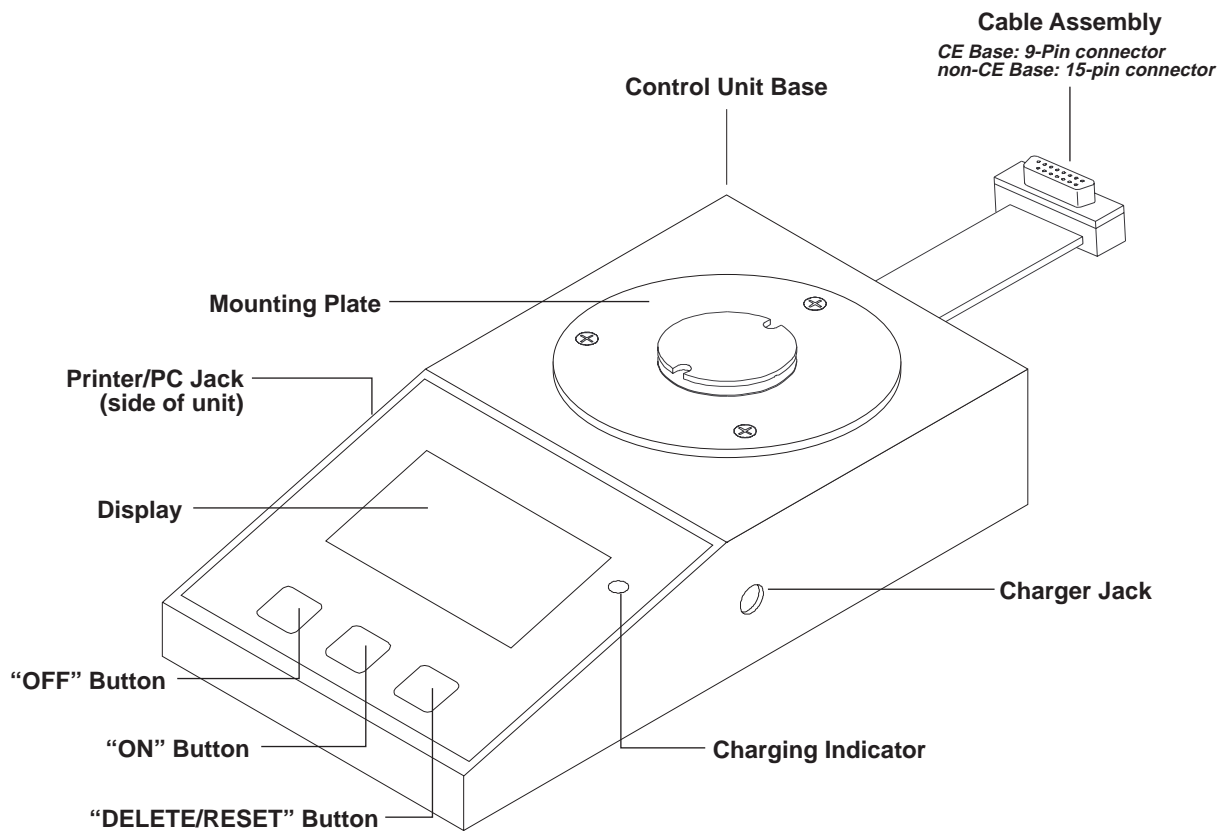

Figure 2.1
Control Unit

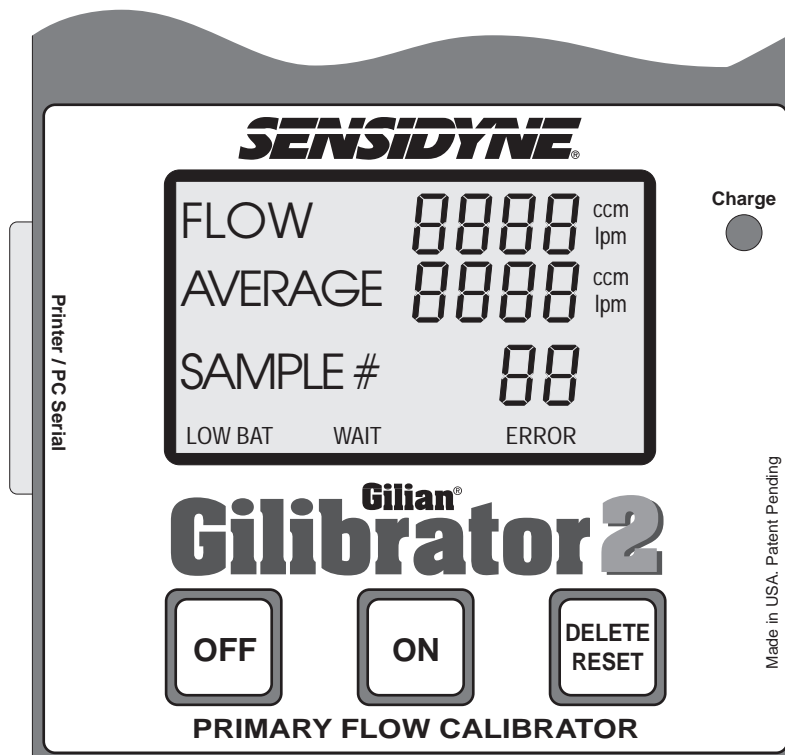

Figure 2.2
Liquid Crystal Display

2.2 PISTON CELL ASSEMBLY

The Piston Cell Assembly (refer to Figure 2.2) is a single unit that need not be disassembled and requires very little maintenance. The assembly contains a precision cylinder-piston assembly.

A green Ready Light on the side of unit signals when the unit is ready and sampling may begin.

A Bleeder Valve located on top of the cell assembly is closed to provide the vacuum necessary to move the piston up the tube.

Secured to the flow tube and secured between the upper and lower portions of the cell assembly, is the Sensor Rail (refer to Figure 2.3). The Sensor Rail includes lower and upper infrared sensors used to time the movement of the piston through the flow cell.

The movement of the piston up and down the flow tube provides the means for calculating an accurate flow rate. As the piston moves past two infrared sensors, each sensor transmits a signal to the Control Unit indicating the passage of the piston.

Pulsation Damper

This built-in damper smooths out any pulsation within the airflow and reduces oscillation of the piston assuring maximum accuracy.

The Piston Cell Assembly has a flow rate range from 1 to 5 LPM.

IMPORTANT NOTE

CE approved Control Unit Bases have 9-Pin cables and CANNOT be used with Piston Cells. Non-CE Control Unit Bases have 15-Pin cables and can be used with Piston Cells.

2.3 WET CELL ASSEMBLY

The Wet Flow Cell Assembly (refer to Figure 2.4) consists of a Bubble Generator and Sensor Block. Each Bubble Generator is sized to produce a bubble film stretched across the diameter of the flow cell tube. The bubble is carried by airflow from the bottom to the top of the tube. As the bubble moves past two infrared sensors, each sensor transmits a signal to the Control Unit indicating the passage of the bubble film. A manual push-button on the Flow Cell Assembly starts the bubble film on its travel up the tube.

Wet Cell Assemblies come in three sizes and can be used with both CE and non-CE Control Base Units:

- Low Flow (1 to 250 ccm)
- Standard Flow (20 ccm to 6 lpm)
- High Flow (2 to 30 lpm)

2.3.1 Bubble Generator Components

The Bubble Generator uses a special soap solution to generate the bubbles. This specially compounded low residue soap is designed to provide high film strength and compatibility with the materials used in the Flow Cell Assembly.

WARNING

Only use Soap Solution Part No. 800450 with the Wet Cell Assembly. Use of other soap solutions can damage the Flow Cell.

Pulsation Damper

This built-in damper smooths out any pulsation within the airflow and reduces oscillation of the bubble film assuring maximum accuracy.

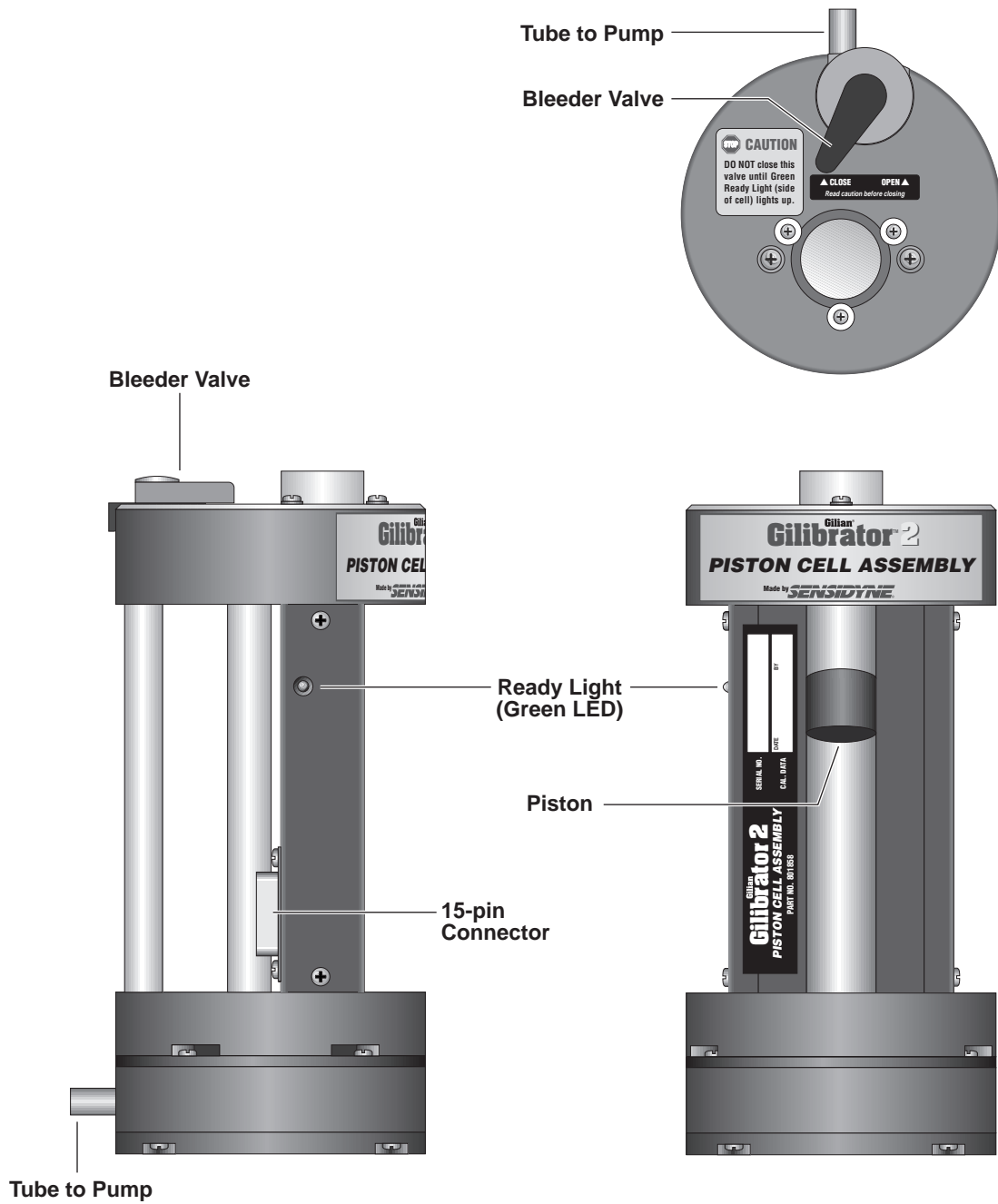

Figure 2.3
Piston Cell Assembly

Bubble Initiate Button

This push-button lowers the Bubble Generator Ring into the soap solution reservoir. When the button is released, the ring lifts out of the soap solution and a film bubble is generated across the opening of the flow tube.

Bubble Breaker

The Bubble Breaker is a secondary chamber in the upper section of the flow cell that provides the traveling soap bubble a rapid expansion path. This is instrumental in breaking the bubble. It also prevents excessive wall wetting by the soap film and allows it to flow back into the base of the cell.

Storage Tubing

The anti-spill storage tubing connects the upper and lower cell chambers and prevents the soap solution from evaporating. Evaporation can may cause the soap solution concentration to change.

CAUTION

If transporting a Wet Cell Assembly by plane, be sure to disconnect the Storage Tubing from either the Air Outlet Boss (upper) or Air Inlet Boss (lower). This prevents the Flow Cell Assembly from becoming pressurized and possibly causing a rupture within the Bubble Generator.

2.3.2 Sensor Block

Surrounding the flow tube and secured between the upper and lower chamber of the bubble generator, is the Sensor Block (refer to Figure 2.4). The block includes lower and upper infrared sensors used to time the movement of bubbles through the Flow Cell. This block is secured to the Bubble Generator Assembly with two locking screws, allowing easy removal of the Sensor Block for Flow Cell maintenance.

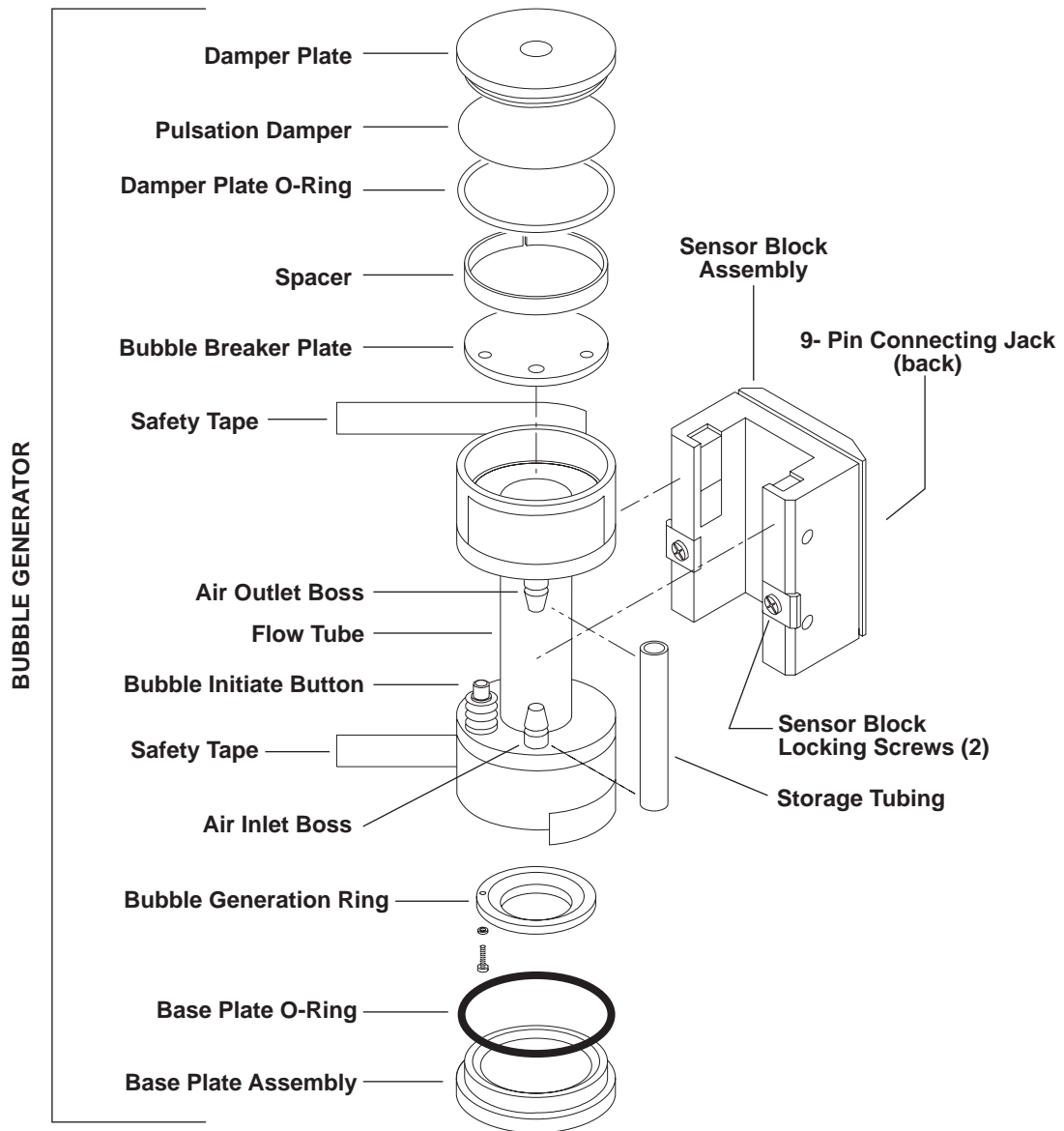

Figure 2.4
Wet Cell Assembly (Exploded View)

3.1 SYSTEM SET-UP

This section describes the steps necessary to set up the Gilibrator 2 Calibration System. This includes initial setup, mounting the Cell Assembly, connecting the cabling, adding soap solution to wet cell assemblies, and setting up the sampling source. Figure 3.1 shows how a complete Gilibrator 2 Calibration System may be configured.

Prior to setup make certain you have properly connected the battery charger to the Charger Jack in the Control Unit) and to an appropriate AC wall outlet. If the charger/adaptor is properly connected, the Charge Indicator should light up.

If you plan to use the Gilibrator 2 in the field, make certain the unit is fully charged (at least 14 hours) before operating the unit. If you plan to use the unit in the lab (i.e., near an AC wall outlet), you can continue with setup and operation immediately.

IMPORTANT COMPATIBILITY NOTE

Most flow cells designed for the original Gilibrator base are compatible with your new Gilibrator 2 base unit. If your existing flow cell is not compatible with the Gilibrator 2 base, the unit will display a false SAMPLE# reading immediately after start-up. If this happens, your flow cell needs to be returned to Sensidyne to be upgraded. See Appendix C (page 30) for more information.

3.2 CELL ASSEMBLY SET-UP

3.2.1 Cell Assembly Mounting

Refer to Figures 3.2 & 3.3. Perform the following steps to mount the Cell Assembly.

CAUTION

Always mount or remove the Cell Assembly by grasping and rotating only the lower part of the assembly.

- 1) The Control Unit Base should be positioned on a flat, level surface.
- 2) Select the appropriate Cell Assembly (Piston, Low, Standard, or High).
- 3) Grasp the *lower portion* of the Cell Assembly and move it to the Mounting Plate on the Control Unit.
- 4) With the front of the Cell Assembly facing right (see Figure 3.2), lower the assembly onto the Mounting Plate on the Control Unit.
- 5) Align the Mounting Pins on the Flow Cell with the Mounting Slots on the Mounting Plate (see Figure 3.3). If alignment is successful, the bottom of the Flow Cell should mount flush with the Mounting Plate.
- 6) While grasping *only the lower portion* of the Flow Cell Assembly, rotate it in a clockwise direction until it “clicks” into place. The front of the Cell Assembly should face toward the display on the Control Unit.

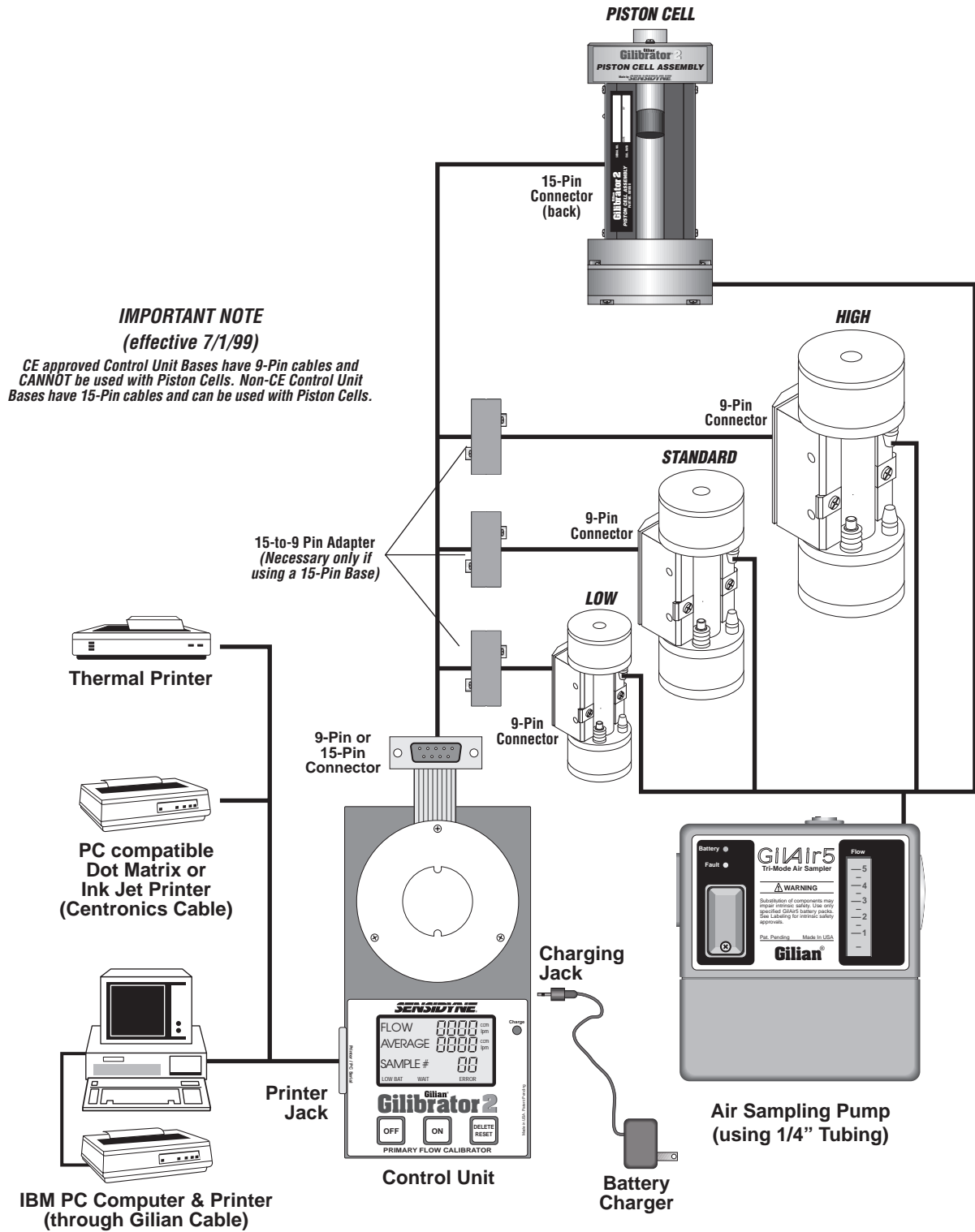

Figure 3.1
Gilibrator 2 System Setup

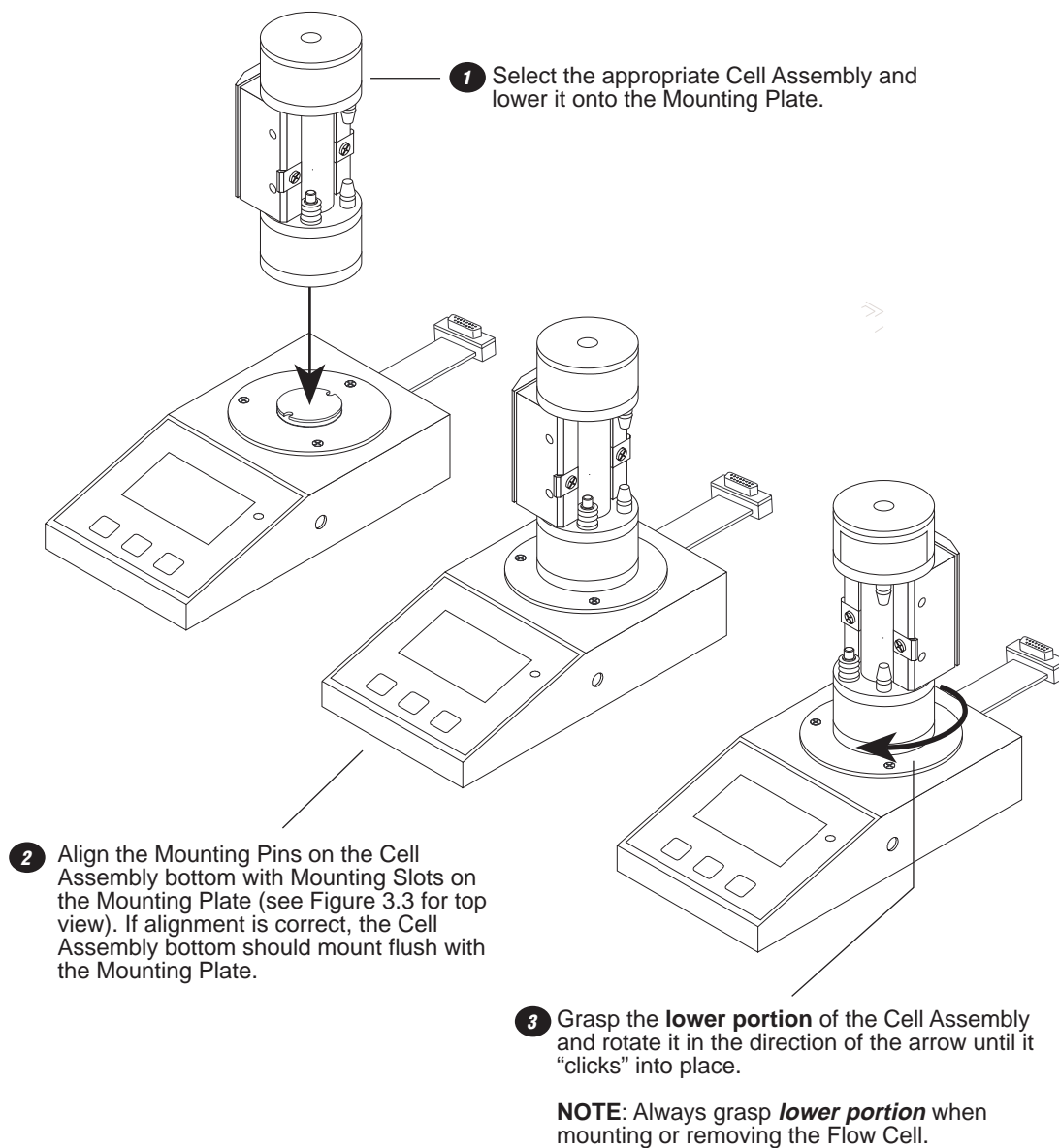

Figure 3.2
Cell Assembly Mounting (3-D View)

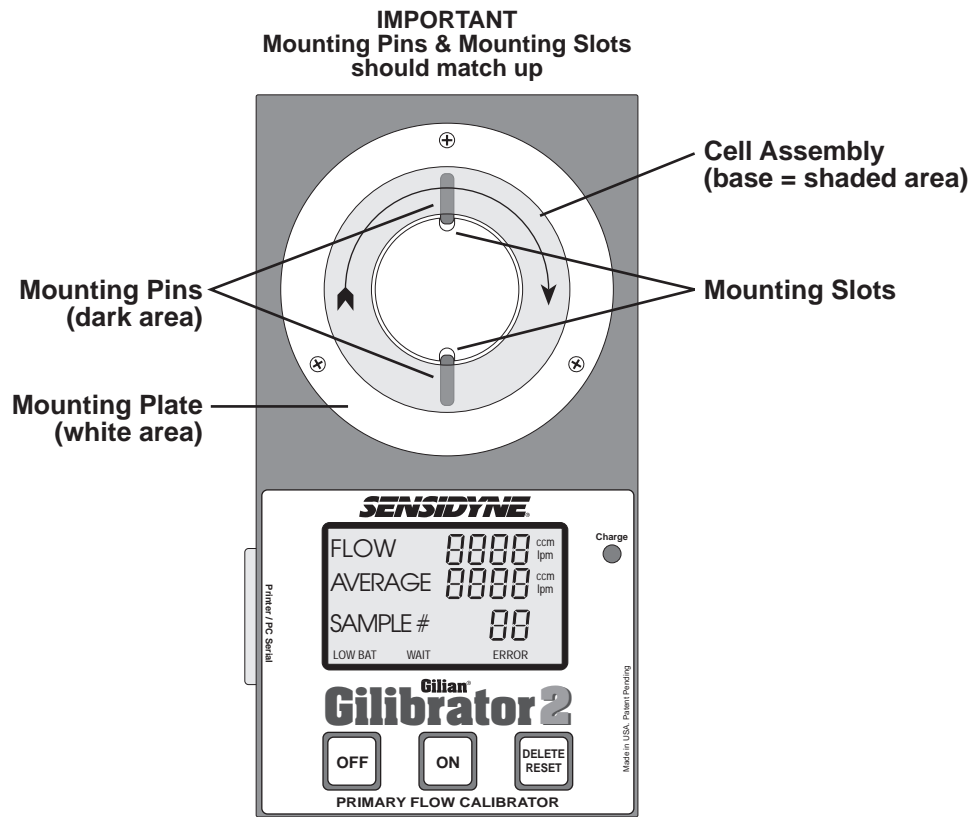

Figure 3.3
Cell Assembly Mounting (Top View)

3.2.2 Cabling Connections

IMPORTANT

Turn off the unit before connecting any cables.

If you are using a Piston Cell Assembly, insert the 15-Pin Interface Plug directly into the Connecting Jack located on the back of the Piston Cell (refer to Figure 2.3). Be sure to properly match up the connectors before engaging.

If you are installing a Wet Cell Assembly on a 15-Pin Control Base, insert the 15-Pin Interface Plug from the Control Base into the 15-to-9 pin adapter. Insert the adapter into the Connecting Jack located on the back of the Wet Cell (refer to Figure 2.4). Be sure to properly match up the connectors before engaging.

If you are installing a Wet Cell on a 9-Pin Control Base, insert the 9-Pin Interface Plug from the Control Base directly into the Connecting Jack located on the back of the Wet Cell (refer to figure 2.4). Be sure to properly match up the connectors before engaging.

Connect the appropriate optional printer (or computer) cable to the Printer Jack located on the left side of the Control Unit. Make certain the cable and Printer Jack connectors match up before making a complete connection. Once the cable has been properly connected, turn on the printer (or computer) and make certain it is prepared to receive data before turning on the Gilibrator 2 unit.

3.2.3 Adding Soap Solution (Wet Cell only)

WARNING

Only use Soap Solution Part No. 800450 with the Flow Cell Assembly. Use of other soap solutions can damage the Flow Cell.

Add soap solution to the unit as follows:

- 1) Remove the Storage Tubing from the Air Outlet Boss (see Figure 2.3) of the Flow Cell. Fill the dispenser bottle provided with Gilibrator soap solution. Using the rubber Storage Tubing as a funnel, slowly add soap solution from the dispenser (refer to Figure 3.4).

- 2) The amount of soap needed is determined by depressing the Bubble Initiate Button and holding it down in the lower position. Continue to add enough soap solution until the angled edge at the bottom of the Bubble Generator Ring is immersed in the solution.

CAUTION

Do Not Overfill.

- 3) After filling is completed, the rubber Storage Tubing may be removed completely. Recap the soap dispenser bottle for later use.

NOTE

If the Wet Cell Assembly is not going to be used for an extended period of time, reinstall the rubber Storage Tubing between the inlet and outlet bosses. This prevents the solution from evaporating and altering the soap concentration in the solution.

WARNING

If you are shipping the Wet Cell, you must remove the rubber Storage Tubing between the inlet and outlet bosses.

3.2.4 Sampling Source Connection

Connect the air sampler to be calibrated to the Air Outlet Boss of the Wet Cell Assembly or the Inlet Tube on the Piston Cell Assembly. Use 1/4" ID tubing in either case.

WET CELL NOTE

A liquid trap between the sampler and the Wet Cell Assembly is recommended. This prevents moisture from carrying over into the sampler during continuous calibration periods.

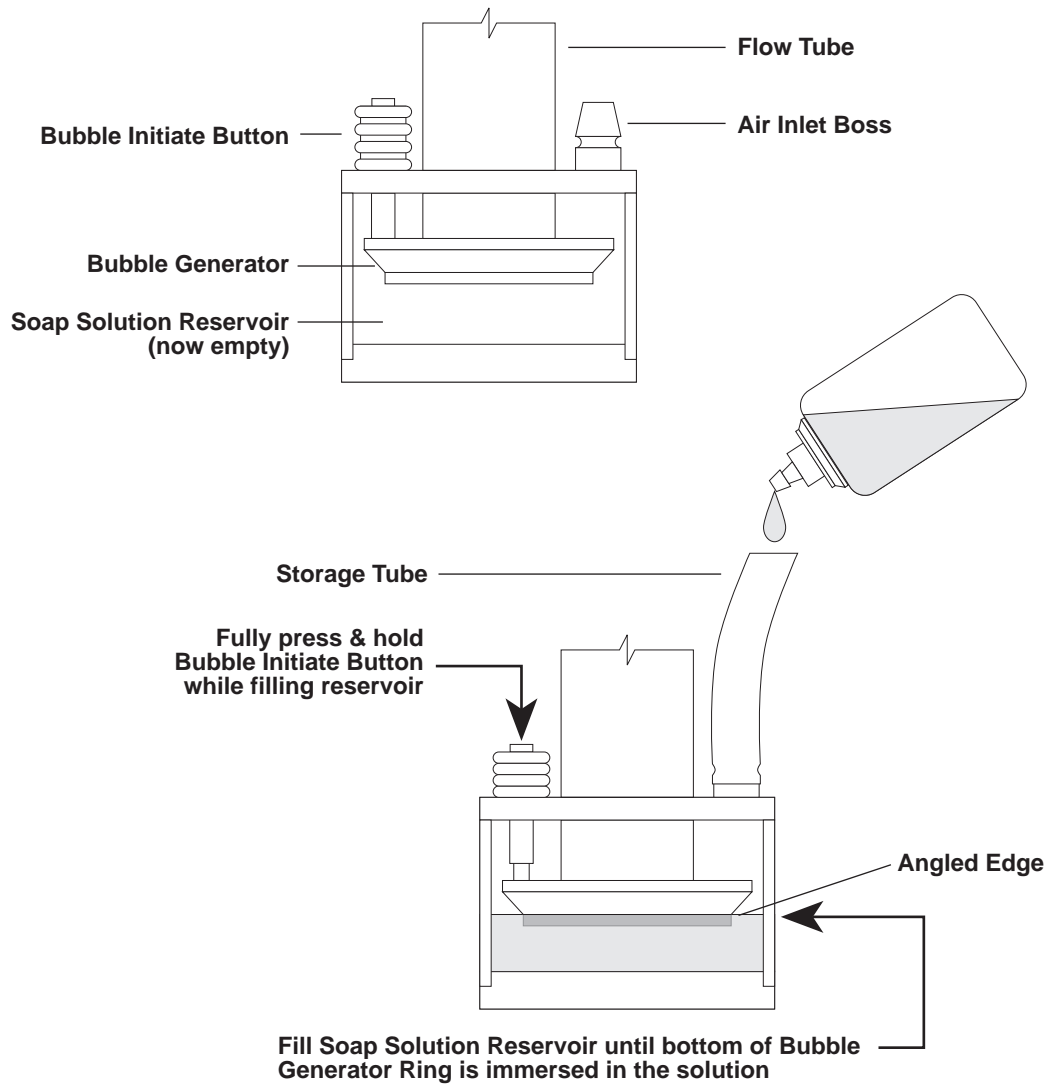

Figure 3.4
Adding Soap Solution (Wet Cell)

4.1 PISTON CELL OPERATION

IMPORTANT NOTE

CE approved Control Unit Bases have 9-Pin cables and CANNOT be used with Piston Cells. Non-CE Control Unit Bases have 15-Pin cables and can be used with Piston Cells.

4.1.1 Start Up

- 1) Press the **ON** and **DELETE/RESET** buttons simultaneously.
- 2) Adjust the sample size by pressing the **DELETE/RESET** button. The sample size can range from 5 to 95 in steps of 5.
- 3) Press the **ON** button. The unit will go through its initial start-up sequence.
- 4) When the Ready Light (green LED) goes on, the unit is ready for operation.
- 5) Close the Bleeder Valve to begin operation of the cell piston.
- 6) The unit will measure and record the number of samples set in Step 2. When that number is reached, the piston will continue to operate but no more data will be recorded on the display.

WARNING

Do not open the Bleeder Valve while samples are being taken. This will cause the next reading (and the average) to be in error. It is okay to open the Bleeder Valve AFTER the last sample has been taken.

- 7) To take another set of samples, press the **DELETE/RESET** button.

If a printer is used, be sure it has completed its printing sequence before pressing the **DELETE/RESET** button. When this button is pressed for less than 1 second, a negative symbol appears on the Control Unit display. The printer also initiates a line showing this subtraction. If a computer is connected, this subtraction is shown on the computer screen.

4.1.2 Flow Readout

• Display

The Control Unit displays the actual flow for each sample, as well as the accumulative average flow rate across samples, and the current sample number.

To delete an obviously false reading, push the **DELETE/RESET** button for about 1 second. This automatically deletes the false information from the average. The average and sample number revert back to the previous reading.

To re-initiate the entire sequence, push the **DELETE/RESET** button for at least 3 seconds. This zeroes all samples and averages within the Control Unit and causes the printer (or computer) to index one line and reprint (or re-display) the sequence headings. This denotes the start of a new sequence.

• Printer

The printer will print in sequence the flow, average, and sample number of each successive bubble reading.

NOTE

In order to use the "Paper Feed" function of the printer, turn the Power Switch "OFF" and "ON" again.

4.2 WET CELL OPERATION

4.2.1 Start Up

Turn on the sampling source.

Depress the Bubble Initiate Button several times to wet the inner walls of the flow tube. You will not be able to initiate a timing bubble without first “priming” the flow tube. You will develop a feel for bubble generation with practice.

After the Flow Tube walls have been primed, Push the **ON** button on the Control Unit. Wait approximately 10 seconds while the unit conducts self-tests and sends a header line to the printer or computer (if one is connected).

4.2.2 Bubble Generation

- 1) For optimum bubble generation, depress the Bubble Initiate Button and hold to initiate the first bubble to travel up the flow tube. Release the button to initiate a second bubble to travel up the Flow Tube. Repeat this process to obtain additional readings. This will be the standard procedure to making clean, consistent bubbles.
- 2) As the bubble rises up the Flow Tube, it initiates a timing sequence when it passes the lower sensor and completes the timing sequence when it passes the upper sensor. The timing information is then transmitted to the control unit where the necessary calculations are performed and a flow reading appears on the display.

IMPORTANT

*If a bubble breaks before the time sequence is completed, timing will continue until another bubble is generated to trip the upper sensor. This causes an erroneous reading and should be subtracted from the average by pressing the **DELETE** Button for about 1 second.*

If a printer is used, be sure it has completed its printing sequence before pressing the **DELETE/RESET** button. When this button is pressed for less than 1 second, a negative symbol appears on the Control Unit display. The printer also initiates a line showing this subtraction. If a computer is connected, this subtraction is shown on the computer screen.

4.2.3 Flow Readout

• **Display**

The Control Unit displays the actual flow for each sample, as well as the accumulative average flow rate across samples, and the current sample number.

To delete an obviously false reading, push the **DELETE/RESET** button for about 1 second. This automatically deletes the false information from the average. The average and sample number revert back to the previous reading.

To re-initiate the entire sequence, push the **DELETE/RESET** button for at least 3 seconds. This zeroes all samples and averages within the Control Unit and causes the printer (or computer) to index one line and reprint (or re-display) the sequence headings. This denotes the start of a new sequence.

• **Printer**

The printer will print in sequence the flow, average, and sample number of each successive bubble reading.

NOTE

In order to use the “Paper Feed” function of the printer, turn the Power Switch “OFF” and “ON” again.

SECTION FIVE

STORAGE & MAINTENANCE

5.1 STORAGE

The Gilibrator 2 is designed so that little maintenance is required. However, periodic cleaning, calibration and replacement of the Damper Diaphragm on the Wet Cell Assembly may be required to ensure years of trouble-free operation.

• Short-Term

Turn Off the Control Unit, the sampling source, and any attached output devices (if applicable).

If the unit is to be used daily, remove the air sampler connection. If using a Wet Cell Assembly, connect the Storage Tubing to both the Air Outlet Boss (upper) and Air Inlet Boss (lower). Plug in the battery charger and connect it to the Control Unit Charging Jack. Recharge the unit overnight (14 hours) for next day usage.

• Long-Term

If the Gilibrator is not to be used for long periods of time, use the following procedures to keep the unit in proper working order.

- 1) Disconnect the Cable Assembly from the connector on the Cell Assembly.
- 2) Remove the Cell Assembly from the Control Unit (Base) in the reverse order in which it was mounted.
- 3) (Wet Cell only) Pour the soap solution out of the Flow Cell through the Air Inlet Boss. To do this, hold the Wet Cell Assembly horizontally (Air Inlet Boss closest to ground), and then tilt the assembly until the Air Inlet Boss is tipped downward at a 45° angle.
- 4) (Wet Cell only) Continue holding the Flow Cell Assembly horizontally until all of the soap solution has poured out.

5.2 PISTON CELL MAINTENANCE

The Piston Cell Assembly is virtually maintenance free. As such, the Piston Cell should not be disassembled. In the rare event that maintenance on the Piston Cell is needed, return the unit to the factory (see Appendix C for information on obtaining a Returned Material Authorization).

You should also return the unit to the factory annually for calibration. Contact the Sensidyne Service Department for an RMA number, information, and pricing (refer to Appendix C).

5.3 WET CELL MAINTENANCE

WARNING

Never use alcohol, acetone or any other harsh cleaners to clean the bubble generator cell.

5.3.1 General Maintenance

- 1) Refer to Figures 2.4 and 4.1. Remove the Sensor Block by loosening the 2 holding screws and sliding the block out and away from the Cell Assembly.
- 2) Remove the Safety Tape from the lip of the Damper Plate Assembly.
- 3) Using a small flat blade screw driver, lift off the Damper Plate using the notch between the upper chamber and the lid.
- 4) Remove the Spacer and then the Bubble Breaker Plate. This gives complete access to the interior of the Flow Cell Tube. Run clear water through the cell until the water exiting the cell runs clear. Rock the cell back and forth to empty out all excess water.
- 5) Replace the Bubble Breaker Plate and center the Air Outlet Boss with the plate's largest hole. Insert the spacer.
- 6) To replace the Damper Plate assembly, moisten the O-ring with soap solution and then press the Damper Plate into the top of the Upper Cell Chamber. Use your fingers to firmly squeeze plate into upper flow cell chamber.
- 7) Apply Safety Tape around the lip of the Damper Plate Assembly.
- 8) Replace the Sensor Block Assembly. Secure the block to the Cell Assembly by tightening the locking screws.

CAUTION

Never exert your body weight on the Bubble Generator to press the plate into place. Excessive weight on the Cell Assembly may result in breakage.

5.3.2 Damper Plate Diaphragm

Refer to Figure 4.1 and perform the procedure as follows:

- 1) Remove the Safety Tape from around the lip of the Damper Plate assembly. Using a small flat blade screwdriver, remove the Damper Plate from the Upper Cell Chamber using the notch provided. Remove the large O-ring and the Pulsation Damper diaphragm.
- 2) To replace, center the new diaphragm over the Damper Plate aperture and roll the O-ring over the diaphragm and into the O-ring groove. If wrinkles occur, repeat the procedure to achieve a smooth placement.
- 3) Bubble the O-ring of Damper Plate and press into the Upper Cell Chamber. Apply Safety Tape around the lip of the Damper Plate Assembly

5.3.3 Additional Wet Cell Maintenance

Leakage Check: The system should be leak checked at 13" H₂O by connecting a manometer to the outlet boss and evacuate the inlet to 13" H₂O. No leakage should be observed.

Calibration: It is recommended that the unit be returned to the factory annually for calibration. Contact the Sensidyne Service Department for an RMA number, information, and pricing (refer to Appendix C).

System Transportation: When transporting the unit, especially by air, it is important that one side of the seal tube which connects the inlet and outlet boss, be removed thereby allowing for equalizing internal pressure within the generator. *Do Not transport unit with soap solution or storage tubing in place.*

CAUTION

Do Not Pressurize the Cell Assembly! Excessive pressure may cause the cell to rupture, resulting in personal injury.

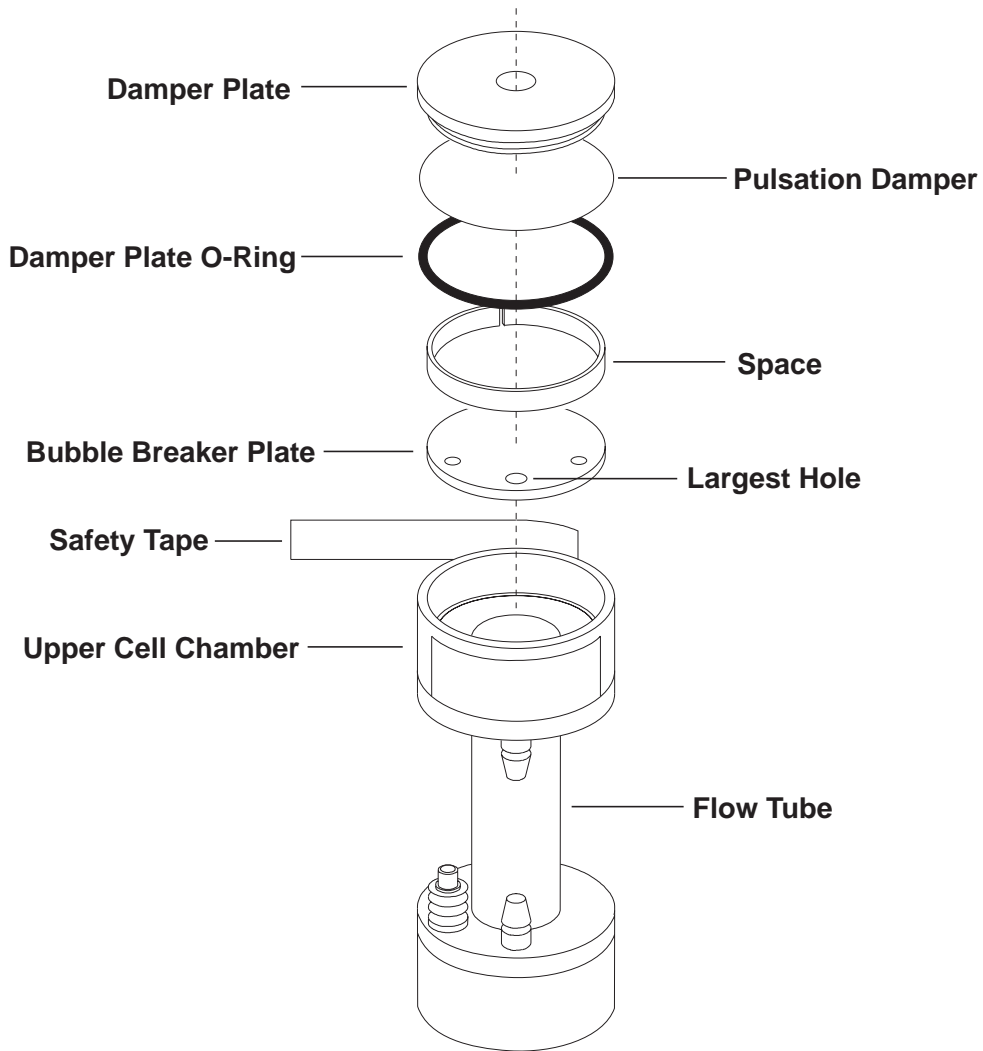

Figure 5.1
Wet Cell Assembly Maintenance

Calibration Kits

Basic: Control Unit, Battery Charger, Carrying Case, Calibration Certificate, Manual, and a Flow Cell (Piston Cell, or a Low, Standard, or High Flow Wet Cell with tubing, soap solution, and dispenser).

Diagnostic: Basic kit, plus Calibration Panel.

Deluxe: Basic kit, plus Printer Module and all three Wet Cells.

Deluxe Diagnostic: Basic kit, plus Calibration Panel, Printer Module, and all three Wet Cells.

All kits come with 15-Pin Control Base Unit, except where noted.

Part No.	Description
Piston Cell Kits (1–5 LPM)	
801868-1	Basic (115 VAC)
801868-2	Basic (230 VAC)
801868-3	Basic, with Printer (115 VAC)
801868-4	Basic, with Printer (230 VAC)
801869-1	Diagnostic, (115 VAC)
801869-2	Diagnostic (230 VAC)
801869-3	Diagnostic, with Printer (115 VAC)
801869-4	Diagnostic, with Printer (230 VAC)
High Flow Wet Cell Kits (2–30 LPM)	
800270	Basic (120 VAC)
800270-2	Basic (230 VAC)
800270-2-CE	Basic (230 VAC) [9-Pin CE Base]
Standard Flow Wet Cell Kits (20 cc–6 LPM)	
800271	Basic (115 VAC)
800271-2	Basic (230 VAC)
800271-2-CE	Basic (230 VAC) [9-Pin CE Base]
800844-2	Diagnostic (115 VAC)
800844-2-230	Diagnostic (230 VAC)
800844-2-230-CE	Diagnostic (230 VAC) [9-Pin CE Base]
Low Flow Wet Cell Kits (1 cc–250 cc)	
800272	Low Flow Kit (115 VAC)
800272-2	Low Flow Kit (230 VAC)
800272-2-CE	Low Flow Kit (230 VAC) [9-Pin CE Base]
800844-1	Diagnostic Kit (115 VAC)
800844-1-230	Diagnostic Kit (230 VAC)
800844-1-230-CE	Diagnostic Kit (230 VAC) [9-Pin CE Base]
Deluxe Kits (includes all three Wet Cells)	
800275	Deluxe Kit (115 VAC)
800275-2	Deluxe Kit (230 VAC)
800275-2-CE	Deluxe Kit (230 VAC) [9-Pin CE Base]
801804	Deluxe Kit, No Printer (115 VAC)
801804-1	Deluxe Kit, No Printer (230 VAC)
801804-1-CE	Deluxe Kit, No Printer (230 VAC) [9-Pin CE Base]
800844-4	Deluxe Diagnostic Kit (115 VAC)
800844-4-230	Deluxe Diagnostic Kit (230 VAC)
800844-4-230-CE	Deluxe Diagnostic Kit (230 VAC) [9-Pin CE Base]

Important Note

CE approved Control Unit Bases have 9-Pin cables and CANNOT be used with Piston Cells. Non-CE Control Unit Bases have 15-Pin cables and can be used with Piston Cells.

APPENDIX A

PARTS LIST

Accessories

Part Number	Item/Description
800274	Printer Module Kit (115 VAC) <i>(includes printer, paper, charger, & cable assembly)</i>
800274-230	Printer Module Kit (230 VAC) <i>(includes printer, paper, charger, & cable assembly)</i>
700721	Printer only
850260	Flow Monitoring Software Kit for Windows <i>(includes cable, software, & manual)</i>
850082	<i>PC Interface Cable only</i>
850262	<i>Program Disk Set only</i>
850260M	<i>Software User Manual only</i>
801841	Deluxe Carry Case for 3 cells
200904	Latex Tubing, 18" (Standard/High Flow), 1/4" [ID] x 7/16" [OD], 2pieces
200914	Latex Tubing, 18" (Low Flow), 1/8" [ID] x 7/16" [OD], 2 pieces
401984	Gilibrator-2 AC Charger/Adapter (115 VAC)
7017010	Gilibrator-2 AC Charger/Adapter (230 VAC)
400674	Gilibrator AC Charger/Adapter (115 VAC)
400794-1	Gilibrator AC Charger/Adapter (230 VAC)

Spares

Part Number	Item/Description
850190	Control Base Unit (15-Pin Cable)
850190-1	Control Base Unit (9-Pin Cable) [CE]
850190U	Control Base upgrade for use with Piston Cell (call Customer Service) <i>Non-CE applications only</i>
801858	Piston Cell Assembly [1 to 5 LPM] <i>(can only be used with non-CE Control Bases - effective 7/1/99)</i>
850268	DB15 to DB9 Adapter (for use with Wet Cells)
800267-1	Low Flow Wet Cell Assembly [1–250 cc/m]
800266-1	Standard Flow Wet Cell Assembly [20 cc/m–6 LPM]
800265-1	High Flow Wet Cell Assembly [2–30 LPM]
200789	Storage Tubing (Low Flow) —3/16" [ID] x 5/16" [OD] x 1 1/2" [length]
200666	Storage Tubing (Standard Flow) —1/4" [ID] x 7/16" [OD] x 2 3/4" [length]
200649	Storage Tubing (High Flow) —1/4" [ID] x 7/16" [OD] x 4 1/2" [length]
800331	Safety Tape (10 ft)
800450	Flow Cell Soap Solution (8 oz.)
400667	Soap Dispenser Bottle
800402	Standard Carrying Case
700560	Gilibrator-2 Battery Pack
400692	Gilibrator Battery Pack
850190M	Operation & Service Manual

• SPECIFICATIONS

General Specifications

Base Unit Construction	Painted aluminum sheet metal
Unit Orientation	Base: Horizontal, on flat surface
Controls	“ON” Button “OFF” Button “DELETE/RESET” Button
Indicators	Display (LCD) Charge Indicator (LED)
Display Data	Flow (4-digit) Average (4-digit) Sample# (2-digit)
Display Ranges	Flow: 0–9999 Average: 0–9999 Sample#: 0–99
Display Messages	Low Bat Wait Error 1 Error 2
Viewing Angle	60°

Performance Specifications

Operating Temperature	5° to 35°C (41° to 95°F)
Storage Temperature	0° to 50°C (32° to 122°F)
Operating Humidity	0–85 %RH, non-condensing
Storage Humidity	0–100 %RH, non-condensing
Accuracy	Better than 1% (Wet Cell) Better than 3% (Piston Cell)

Electrical Specifications

Power Source (DC)	Internal Battery Pack
Battery Type	Rechargeable
Battery Charge Time	14 hours
Expected Battery Life	over 300 charge/recharge cycles
Input Voltage	5.5–7.5 Vdc
Input Current	50–60 mA
Transmission Link Requirements	RS-232
Interface Connectors	Charger Jack (2.1 mm barrel jack) Connecting Jack – Sensor Block (DB-9) [Wet Cell] Connecting Jack – Sensor Rail (DB-15) [Piston Cell] Printer Jack (DB-25)

APPENDIX C

RETURNED MATERIAL AUTHORIZATION

Sensidyne maintains an instrument service facility at the factory to provide its customers with both warranty and non-warranty repair. Sensidyne assumes no liability for service performed by personnel other than Sensidyne personnel. To facilitate the repair process, please contact the Sensidyne Service Department in advance for assistance with a problem which cannot be remedied and/or requires the return of the product to the factory. All returned products require a Returned Material Authorization (RMA) number. Sensidyne Service Department personnel may be reached at:

Sensidyne
16333 Bay Vista Drive
Clearwater, FL 33760 USA
800-451-9444 • 727-530-3602
727-538-0671 [Service Fax]

All non-warranty repair orders will have a minimum fee of \$50 whether the repair is authorized or not. This fee includes handling, administration and technical expenses for inspecting the instrument and providing an estimate. However, the estimate fee is waived if the repair is authorized.

If you wish to set a limit to the authorized repair cost, state a "not to exceed" figure on your purchase order. Please indicate if a price quotation is required before authorization of the repair cost, understanding that this invokes extra cost and handling delay. Sensidyne's re-

pair policy is to perform all needed repairs to restore the instrument to its full operating condition.

Repairs are handled on a "first in - first out" basis. Your order may be expedited if you authorize an expediting fee. This will place your order next in line behind orders currently in process.

Pack the instrument and its accessories (preferably in their original packing) and enclose your return address, purchase order, shipping and billing information, RMA number, a description of the problem encountered with your instrument and any special instructions. All prices are subject to change without notice.

If this is the first time you are dealing directly with the factory, you will be asked to prepay or to authorize a COD shipment.

Send the instrument, prepaid, to:

SENSIDYNE
16333 BAY VISTA DRIVE
CLEARWATER, FL 33760 USA

ATTENTION: Service Department

RMA #: _____

SERVICE OPTIONS

The Sensidyne Service Department offers a variety of service options which will minimize costly interruptions and maintenance costs. These options include initial training, on-site technical assistance, and full factory repairs. Sensidyne has developed several programs which offer options best suited to your applications and needs. For further information, contact the Sensidyne Service Department at the following numbers: 800-451-9444 • 727-530-3602 • 727-538-0671 [Service Fax].



Certificate No. 970084

SENSIDYNE[®]

16333 Bay Vista Dr. • Clearwater, FL 33760 • (800) 451-9444 • (727) 530-3602 • (727) 539-0550 [FAX] • www.Sensidyne.com

Revision G • Document No. 850190M